

PRODUCT INFORMATION & MANUAL

Human IL-6 Platinum ELISA

BMS213/2 / BMS213/2TEN

Enzyme-linked Immunosorbent Assay for
quantitative detection of human IL-6.

For research use only.

Not for diagnostic or therapeutic procedures.



Human IL-6 Platinum ELISA

North America

Technical Support:

Research Products:

888.810.6168

858.642.2058

tech@eBioscience.com

Clinical Products:

877.726.8559

858.642.2058

tech@eBioscience.com

Customer Service:

888.999.1371

858.642.2058

info@eBioscience.com

Fax:

858.642.2046

Europe/International*

Technical Support:

+43 1 796 40 40-120

tech@eBioscience.com

Customer Service:

+43 1 796 40 40-305

info@eBioscience.com

Fax:

+43 1 796 40 40-400



Bender MedSystems GmbH

Campus Vienna Biocenter 2

1030 Vienna, Austria

www.eBioscience.com

* Customers outside North America and Europe may contact their eBioscience distributor listed on our website at www.eBioscience.com/distributors.

TABLE OF CONTENTS

1	Intended Use	3
2	Summary	3
3	Principles of the Test	5
4	Reagents Provided	7
5	Storage Instructions – ELISA Kit	9
6	Specimen Collection and Storage Instructions	9
7	Materials Required But Not Provided	10
8	Precautions for Use	11
9	Preparation of Reagents	13
10	Test Protocol	17
11	Calculation of Results	22
12	Limitations	25
13	Performance Characteristics	26
14	Ordering Information	32
15	Reagent Preparation Summary	33
16	Test Protocol Summary	34

1 Intended Use

The human IL-6 ELISA is an enzyme-linked immunosorbent assay for the quantitative detection of human IL-6. **The human IL-6 ELISA is for research use only. Not for diagnostic or therapeutic procedures.**

2 Summary

Interleukin-6 (IL-6) is a multi-functional cytokine that regulates immune responses, acute phase reactions and hematopoiesis and may play a central role in host defense mechanisms. The gene for human IL-6 has been localized to chromosome 7p21. The genomic sequence has been determined. IL-6 is usually not produced constitutively by normal cells, but its expression is readily induced by a variety of cytokines, lipopolysaccharide or viral infections. The IL-6 gene product is a single chain protein with a molecular mass ranging from 21 to 28 kDa, depending on the cellular source. Extensive posttranslational modifications like N- and O-linked glycosylation as well as phosphorylation seem to account for this heterogeneity. The cDNA for IL-6 predicts a precursor protein of 212 amino acids.

IL-6 is a pleiotropic cytokine produced by a variety of cells. It acts on a wide range of tissues, exerting growth-induction, growth-inhibition, and differentiation respectively, depending on the nature of the target cells.

IL-6 is involved in

- the induction of B-cell differentiation,
- the induction of acute phase proteins in liver cells,
- growth promotion of myeloma/plasmacytoma/hybridoma cells,
- induction of IL-2 and IL-2 receptor expression,
- proliferation and differentiation of T cells,
- inhibition of cell growth of certain myeloid leukemic cell lines and induction of their differentiation to macrophages,
- enhancement of IL-3-induced multipotential colony cell formation in hematopoietic stem cells and induction of maturation of megakaryocytes as a thrombopoietic factor,
- induction of mesangial cell growth,
- induction of neural differentiation of PC 12 cells and
- induction of keratinocyte growth.

The abnormal production of IL-6 was first suggested to be related to polyclonal B-cell activation with autoantibody production in patients with

cardiac myxoma. Since then, IL-6 has been suggested to be involved in the pathogenesis of a variety of diseases. Measurement of IL-6 levels in serum and other body fluids thus provides more detailed insights into various pathological situations.

Infections:

Body fluids of patients with acute local bacterial or viral infections and serum of patients with gram-negative or positive bacteremia contain elevated levels of biologically active IL-6.

Obstetric Infections:

IL-6 has emerged as a reporter cytokine for intraamniotic infection.

Diseases associated with an altered immune system (polyclonal B-cell abnormalities or autoimmune diseases):

Elevated levels of circulating IL-6 have been detected in patients with cardiac myxoma, Castleman's disease, rheumatoid arthritis, IgM gammopathy and in those with acquired immunodeficiency syndrome as well as alcoholic liver cirrhosis.

Proliferative diseases:

Elevated plasma levels of IL-6 are observed in patients with psoriasis and mesangial proliferative glomerulonephritis.

Neoplastic Diseases:

Increased systemic levels of IL-6 have been detected in patients with multiple myeloma, other B-cell dyscrasias, Lennert's T lymphoma, Castleman's disease, renal cell carcinoma and various other solid tumors.

Inflammatory responses:

IL-6 is involved in the induction of acute phase proteins and induction of fever. Elevated serum levels of IL-6 are also found in patients with severe burns, in serum and plasma as a marker for predicting postoperative complications, in serum and urine of recipients of kidney transplants before rejection, in the serum of septic shock patients and in patients with inflammatory arthritis and traumatic arthritis.

For literature update refer to **www.eBioscience.com**

3 Principles of the Test

An anti-human IL-6 coating antibody is adsorbed onto microwells.

Human IL-6 present in the sample or standard binds to antibodies adsorbed to the microwells. A biotin-conjugated anti-human IL-6 antibody is added and binds to human IL-6 captured by the first antibody.

Following incubation unbound biotin-conjugated anti-human IL-6 antibody is removed during a wash step. Streptavidin-HRP is added and binds to the biotin-conjugated anti-human IL-6 antibody.

Following incubation unbound Streptavidin-HRP is removed during a wash step, and substrate solution reactive with HRP is added to the wells.

Figure 1

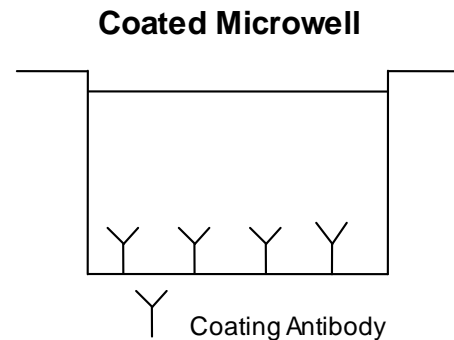

Figure 2

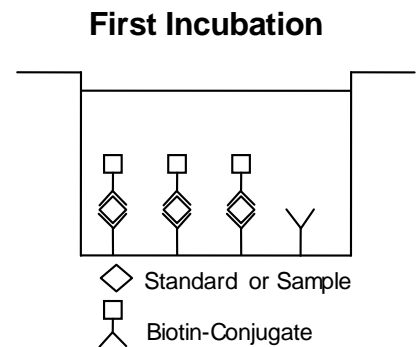

Figure 3

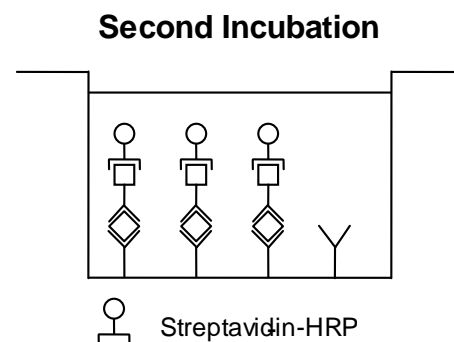
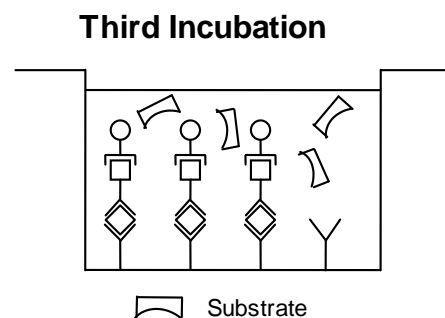
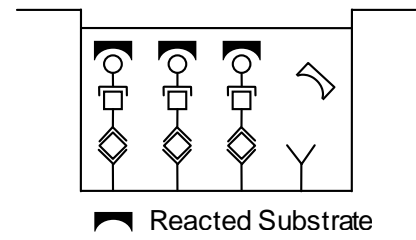

Figure 4



A coloured product is formed in proportion to the amount of human IL-6 present in the sample or standard. The reaction is terminated by addition of acid and absorbance is measured at 450 nm. A standard curve is prepared from 7 human IL-6 standard dilutions and human IL-6 sample concentration determined.

Figure 5



4 Reagents Provided

4.1 Reagents for Human IL-6 ELISA BMS213/2 (96 tests)

- 1 aluminium pouch with a **Microwell Plate coated** with monoclonal antibody to human IL-6
- 1 vial (70 µl) **Biotin-Conjugate** anti-human IL-6 monoclonal antibody
- 1 vial (150 µl) **Streptavidin-HRP**
- 2 vials human IL-6 **Standard**, lyophilized, 200 pg/ml upon reconstitution
- 1 vial **Control high**
- 1 vial **Control low**
- 1 vial (5 ml) **Assay Buffer Concentrate 20x** (PBS with 1% Tween 20, 10% BSA)
- 1 bottle (50 ml) **Wash Buffer Concentrate 20x** (PBS with 1% Tween 20)
- 1 vial (15 ml) **Substrate Solution** (tetramethyl-benzidine)
- 1 vial (15 ml) **Stop Solution** (1M Phosphoric acid)
- 4 **Adhesive Films**

4.2 Reagents for Human IL-6 ELISA BMS213/2TEN (10x96 tests)

- 10 aluminium pouches with a **Microwell Plate coated** with monoclonal antibody to human IL-6
- 10 vials (70 µl) **Biotin-Conjugate** anti-human IL-6 monoclonal antibody
- 10 vials (150 µl) **Streptavidin-HRP**
- 10 vials human IL-6 **Standard** lyophilized, 200 pg/ml upon reconstitution
- 10 vials **Control high**
- 10 vials **Control low**
- 3 vials (5 ml) **Assay Buffer Concentrate 20x**
(PBS with 1% Tween 20, 10% BSA and)
- 5 bottles (50 ml) **Wash Buffer Concentrate 20x**
(PBS with 1% Tween 20)
- 10 vials (15 ml) **Substrate Solution** (tetramethyl-benzidine)
- 1 vial (100 ml) **Stop Solution** (1M Phosphoric acid)
- 20 **Adhesive Films**

5 Storage Instructions – ELISA Kit

Store kit reagents between 2° and 8°C except controls. Store lyophilized controls at -20°C.

Immediately after use remaining reagents should be returned to cold storage (2° to 8°C), controls to -20°C, respectively. Expiry of the kit and reagents is stated on labels.

Expiry of the kit components can only be guaranteed if the components are stored properly, and if, in case of repeated use of one component, this reagent is not contaminated by the first handling.

6 Specimen Collection and Storage Instructions

Cell culture supernatant, serum and plasma (EDTA, citrate, heparin) were tested with this assay. Other body fluids might be suitable for use in the assay. Remove serum from the clot as soon as possible after clotting.

Samples containing a visible precipitate must be clarified prior to use in the assay. Do not use grossly hemolyzed or lipemic specimens.

Samples should be aliquoted and must be stored frozen at -20°C to avoid loss of bioactive human IL-6. If samples are to be run within 24 hours, they may be stored at 2° to 8°C (for sample stability refer to 13.5).

Avoid repeated freeze-thaw cycles. Prior to assay, the frozen sample should be brought to room temperature slowly and mixed gently.

7 Materials Required But Not Provided

- 5 ml and 10 ml graduated pipettes
- 5 μ l to 1000 μ l adjustable single channel micropipettes with disposable tips
- 50 μ l to 300 μ l adjustable multichannel micropipette with disposable tips
- Multichannel micropipette reservoir
- Beakers, flasks, cylinders necessary for preparation of reagents
- Device for delivery of wash solution (multichannel wash bottle or automatic wash system)
- Microwell strip reader capable of reading at 450 nm (620 nm as optional reference wave length)
- Glass-distilled or deionized water
- Statistical calculator with program to perform regression analysis

8 Precautions for Use

- All chemicals should be considered as potentially hazardous. We therefore recommend that this product is handled only by those persons who have been trained in laboratory techniques and that it is used in accordance with the principles of good laboratory practice. Wear suitable protective clothing such as laboratory overalls, safety glasses and gloves. Care should be taken to avoid contact with skin or eyes. In the case of contact with skin or eyes wash immediately with water. See material safety data sheet(s) and/or safety statement(s) for specific advice.
- Reagents are intended for research use only and are not for use in diagnostic or therapeutic procedures.
- Do not mix or substitute reagents with those from other lots or other sources.
- Do not use kit reagents beyond expiration date on label.
- Do not expose kit reagents to strong light during storage or incubation.
- Do not pipette by mouth.
- Do not eat or smoke in areas where kit reagents or samples are handled.
- Avoid contact of skin or mucous membranes with kit reagents or specimens.
- Rubber or disposable latex gloves should be worn while handling kit reagents or specimens.
- Avoid contact of substrate solution with oxidizing agents and metal.
- Avoid splashing or generation of aerosols.
- In order to avoid microbial contamination or cross-contamination of reagents or specimens which may invalidate the test use disposable pipette tips and/or pipettes.
- Use clean, dedicated reagent trays for dispensing the conjugate and substrate reagent.

- Exposure to acid inactivates the conjugate.
- Glass-distilled water or deionized water must be used for reagent preparation.
- Substrate solution must be at room temperature prior to use.
- Decontaminate and dispose specimens and all potentially contaminated materials as they could contain infectious agents. The preferred method of decontamination is autoclaving for a minimum of 1 hour at 121.5°C.
- Liquid wastes not containing acid and neutralized waste may be mixed with sodium hypochlorite in volumes such that the final mixture contains 1.0% sodium hypochlorite. Allow 30 minutes for effective decontamination. Liquid waste containing acid must be neutralized prior to the addition of sodium hypochlorite.

9 Preparation of Reagents

Buffer concentrates should be brought to room temperature and should be diluted before starting the test procedure.

If crystals have formed in the **Buffer Concentrates**, warm them gently until they have completely dissolved.

9.1 Wash Buffer (1x)

Pour entire contents (50 ml) of the **Wash Buffer Concentrate (20x)** into a clean 1000 ml graduated cylinder. Bring to final volume of 1000 ml with glass-distilled or deionized water.

Mix gently to avoid foaming.

Transfer to a clean wash bottle and store at 2° to 25°C. Please note that Wash Buffer (1x) is stable for 30 days.

Wash Buffer (1x) may also be prepared as needed according to the following table:

Number of Strips	Wash Buffer Concentrate (20x) (ml)	Distilled Water (ml)
1 - 6	25	475
1 - 12	50	950

9.2 Assay Buffer (1x)

Pour the entire contents (5 ml) of the **Assay Buffer Concentrate (20x)** into a clean 100 ml graduated cylinder. Bring to final volume of 100 ml with distilled water. Mix gently to avoid foaming.

Store at 2° to 8°C. Please note that the Assay Buffer (1x) is stable for 30 days.

Assay Buffer (1x) may also be prepared as needed according to the following table:

Number of Strips	Assay Buffer Concentrate (20x) (ml)	Distilled Water (ml)
1 - 6	2.5	47.5
1 - 12	5.0	95.0

9.3 Biotin-Conjugate

Please note that the Biotin-Conjugate should be used within 30 minutes after dilution.

Make a 1:100 dilution of the concentrated **Biotin-Conjugate** solution with Assay Buffer (1x) in a clean plastic tube as needed according to the following table:

Number of Strips	Biotin-Conjugate (ml)	Assay Buffer (1x)(ml)
1 - 6	0.03	2.97
1 - 12	0.06	5.94

9.4 Streptavidin-HRP

Please note that the Streptavidin-HRP should be used within 30 minutes after dilution.

Make a 1:200 dilution of the concentrated **Streptavidin-HRP** solution with Assay Buffer (1x) in a clean plastic tube as needed according to the following table:

Number of Strips	Streptavidin-HRP (ml)	Assay Buffer (1x)(ml)
1 - 6	0.03	5.97
1 - 12	0.06	11.94

9.5 Human IL-6 Standard

Reconstitute **human IL-6 Standard** by addition of distilled water. Reconstitution volume is stated on the label of the standard vial. Swirl or mix gently to insure complete and homogeneous solubilization (concentration of reconstituted standard = 200 pg/ml). Allow the standard to reconstitute for 10-30 minutes. Mix well prior to making dilutions.

After usage remaining standard cannot be stored and has to be discarded.

Standard dilutions can be prepared directly on the microwell plate (see 10.c) or alternatively in tubes (see 9.5.1).

9.5.1 External Standard Dilution

Label 7 tubes, one for each standard point.

S1, S2, S3, S4, S5, S6, S7

Then prepare 1:2 serial dilutions for the standard curve as follows:
Pipette 225 µl of Assay Buffer (1x) into each tube.

Pipette 225 µl of reconstituted standard (concentration = 200 pg/ml) into the first tube, labelled S1, and mix (concentration of Standard 1 = 100 pg/ml).

Pipette 225 μ l of this dilution into the second tube, labelled S2, and mix thoroughly before the next transfer.

Repeat serial dilutions 5 more times thus creating the points of the standard curve (see Figure 6).

Assay Buffer (1x) serves as blank.

Figure 6

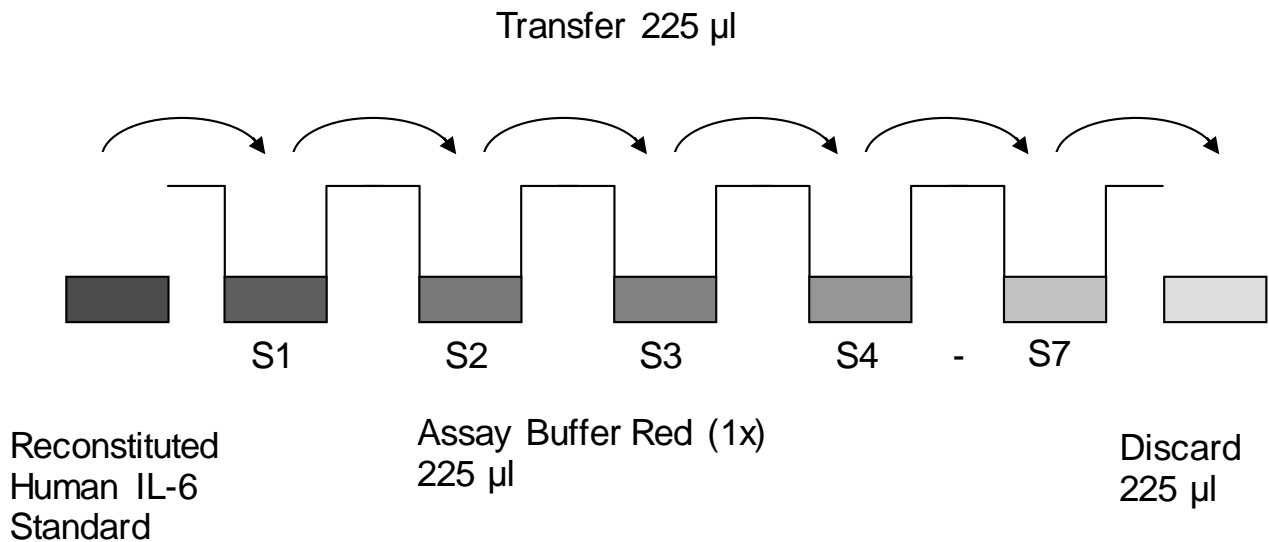

9.6 Controls

Reconstitute by adding 300 μ l distilled water to lyophilized **controls** (10-30 minutes). Swirl or mix gently to ensure complete and homogeneous solubilization. Further treat the controls like your samples in the assay. For control range please refer to certificate of analysis or vial label. Store reconstituted controls aliquoted at -20°C . Avoid repeated freeze and thaw cycles.

10 Test Protocol

- a. Determine the number of microwell strips required to test the desired number of samples plus appropriate number of wells needed for running blanks and standards. Each sample, standard, blank and optional control sample should be assayed in duplicate. Remove extra microwell strips from holder and store in foil bag with the desiccant provided at 2°-8°C sealed tightly.
- b. Wash the microwell strips twice with approximately 400 µl Wash Buffer per well with thorough aspiration of microwell contents between washes. Allow the Wash Buffer to sit in the wells for about **10 – 15 seconds** before aspiration. Take care not to scratch the surface of the microwells.
After the last wash step, empty wells and tap microwell strips on absorbent pad or paper towel to remove excess Wash Buffer. Use the microwell strips immediately after washing. Alternatively microwell strips can be placed upside down on a wet absorbent paper for not longer than 15 minutes. **Do not allow wells to dry.**
- c. **Standard dilution on the microwell plate** (Alternatively the standard dilution can be prepared in tubes - see 9.5.1):
Add 100 µl of Assay Buffer (1x) in duplicate to all **standard wells**. Pipette 100 µl of prepared **standard** (see Preparation of Standard 9.5, concentration = 200.00 pg/ml), in duplicate, into well A1 and A2 (see Table 1). Mix the contents of wells A1 and A2 by repeated aspiration and ejection (concentration of standard 1 S1 = 100.00 pg/ml), and transfer 100 µl to wells B1 and B2, respectively (see Figure 7). Take care not to scratch the inner surface of the microwells. Continue this procedure 5 times, creating two rows of human IL-6 standard dilutions, ranging from 100.00 to 1.56 pg/ml. Discard 100 µl of the contents from the last microwells (G1, G2) used.

Figure 7

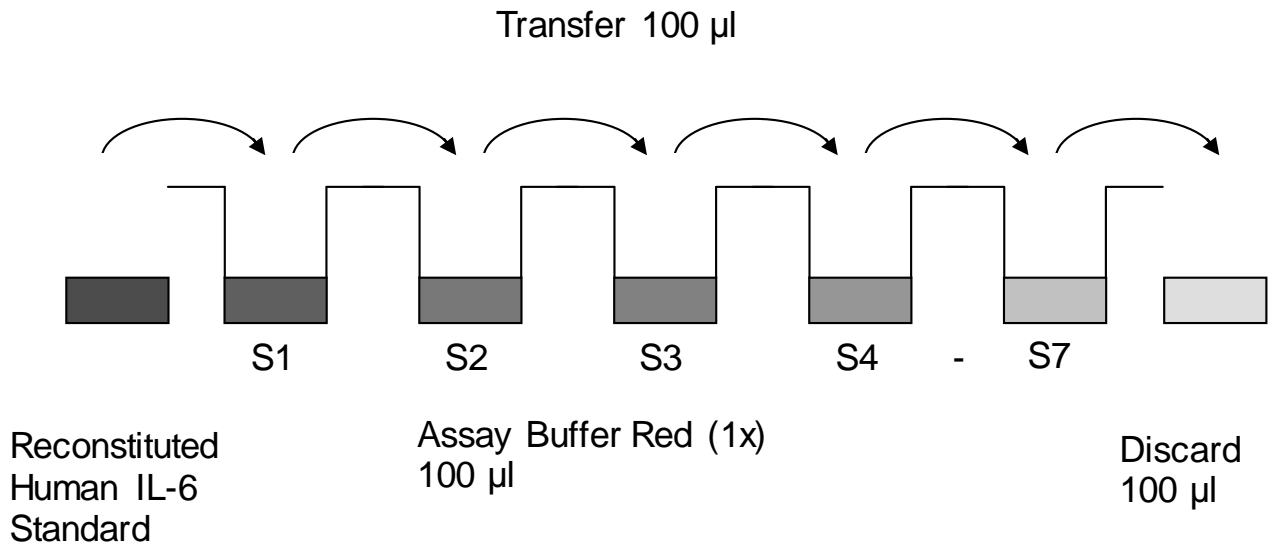

In case of an **external standard dilution** (see 9.5.1), pipette 100 µl of these standard dilutions (S1 to S7) in the standard wells according to Table 1.

Table 1

Table depicting an example of the arrangement of blanks, standards and samples in the microwell strips:

	1	2	3	4
A	Standard 1 (100.00 pg/ml)	Standard 1 (100.00 pg/ml)	Sample 1	Sample 1
B	Standard 2 (50.00 pg/ml)	Standard 2 (50.00 pg/ml)	Sample 2	Sample 2
C	Standard 3 (25.00 pg/ml)	Standard 3 (25.00 pg/ml)	Sample 3	Sample 3
D	Standard 4 (12.50 pg/ml)	Standard 4 (12.50 pg/ml)	Sample 4	Sample 4
E	Standard 5 (6.25 pg/ml)	Standard 5 (6.25 pg/ml)	Sample 5	Sample 5
F	Standard 6 (3.13 pg/ml)	Standard 6 (3.13 pg/ml)	Sample 6	Sample 6
G	Standard 7 (1.56 pg/ml)	Standard 7 (1.56 pg/ml)	Sample 7	Sample 7
H	Blank	Blank	Sample 8	Sample 8

- d. Add 100 µl of **Assay Buffer (1x)** in duplicate to the **blank wells**.
- e. Add 50 µl of **Assay Buffer (1x)** to the **sample wells**.
- f. Add 50 µl of each **sample** in duplicate to the **sample wells**.
- g. Prepare **Biotin-Conjugate** (see Preparation of Biotin-Conjugate 9.3).
- h. Add 50 µl of **Biotin-Conjugate** to all wells.
- i. Cover with an adhesive film and incubate at room temperature (18 to 25°C) for 2 hours, if available on a microplate shaker set at 400 rpm.
- j. Prepare **Streptavidin-HRP** (refer to Preparation of Streptavidin-HRP 9.4).
- k. Remove adhesive film and empty wells. Wash microwell strips 4 times according to point b. of the test protocol. Proceed immediately to the next step.
- l. Add 100 µl of diluted **Streptavidin-HRP** to all wells, including the blank wells.
- m. Cover with an adhesive film and incubate at room temperature (18° to 25°C) for 1 hour, if available on a microplate shaker set at 400 rpm.
- n. Remove adhesive film and empty wells. Wash microwell strips 4 times according to point b. of the test protocol. Proceed immediately to the next step.
- o. Pipette 100 µl of **TMB Substrate Solution** to all wells.
- p. Incubate the microwell strips at room temperature (18° to 25°C) for about 10 min. Avoid direct exposure to intense light.

The colour development on the plate should be monitored and the substrate reaction stopped (see next point of this protocol) before positive wells are no longer properly recordable. Determination of the ideal time period for colour development has to be done individually for each assay.

It is recommended to add the stop solution when the highest standard has developed a dark blue colour. Alternatively the colour development can be monitored by the ELISA reader at 620 nm. The substrate reaction should be stopped as soon as Standard 1 has reached an OD of 0.9 – 0.95.

- q. Stop the enzyme reaction by quickly pipetting 100 µl of **Stop Solution** into each well. It is important that the Stop Solution is spread quickly and uniformly throughout the microwells to completely inactivate the enzyme. Results must be read immediately after the Stop Solution is added or within one hour if the microwell strips are stored at 2 - 8°C in the dark.
- r. Read absorbance of each microwell on a spectro-photometer using 450 nm as the primary wave length (optionally 620 nm as the reference wave length; 610 nm to 650 nm is acceptable). Blank the plate reader according to the manufacturer's instructions by using the blank wells. Determine the absorbance of both the samples and the standards.

Note: In case of incubation without shaking the obtained O.D. values may be lower than indicated below. Nevertheless the results are still valid.

11 Calculation of Results

- Calculate the average absorbance values for each set of duplicate standards and samples. Duplicates should be within 20 per cent of the mean value.
- Create a standard curve by plotting the mean absorbance for each standard concentration on the ordinate against the human IL-6 concentration on the abscissa. Draw a best fit curve through the points of the graph (a 5-parameter curve fit is recommended).
- To determine the concentration of circulating human IL-6 for each sample, first find the mean absorbance value on the ordinate and extend a horizontal line to the standard curve. At the point of intersection, extend a vertical line to the abscissa and read the corresponding human IL-6 concentration.
- **If instructions in this protocol have been followed, samples have been diluted 1:2 (50 µl sample + 50 µl Assay Buffer (1x)) and the concentration read from the standard curve must be multiplied by the dilution factor (x 2).**
- **Calculation of samples with a concentration exceeding standard 1 may result in incorrect, low human IL-6 levels. Such samples require further external predilution according to expected human IL-6 values with Assay Buffer (1x) in order to precisely quantitate the actual human IL-6 levels.**
- It is suggested that each testing facility establishes a control sample of known human IL-6 concentration and runs this additional control with each assay. If the values obtained are not within the expected range of the control, the assay results may be invalid.
- A representative standard curve is shown in Figure 8. This curve cannot be used to derive test results. Each laboratory must prepare a standard curve for each group of microwell strips assayed.

Figure 8

Representative standard curve for human IL-6 ELISA. Human IL-6 was diluted in serial 2-fold steps in Assay Buffer (1x). Do not use this standard curve to derive test results. A standard curve must be run for each group of microwell strips assayed.

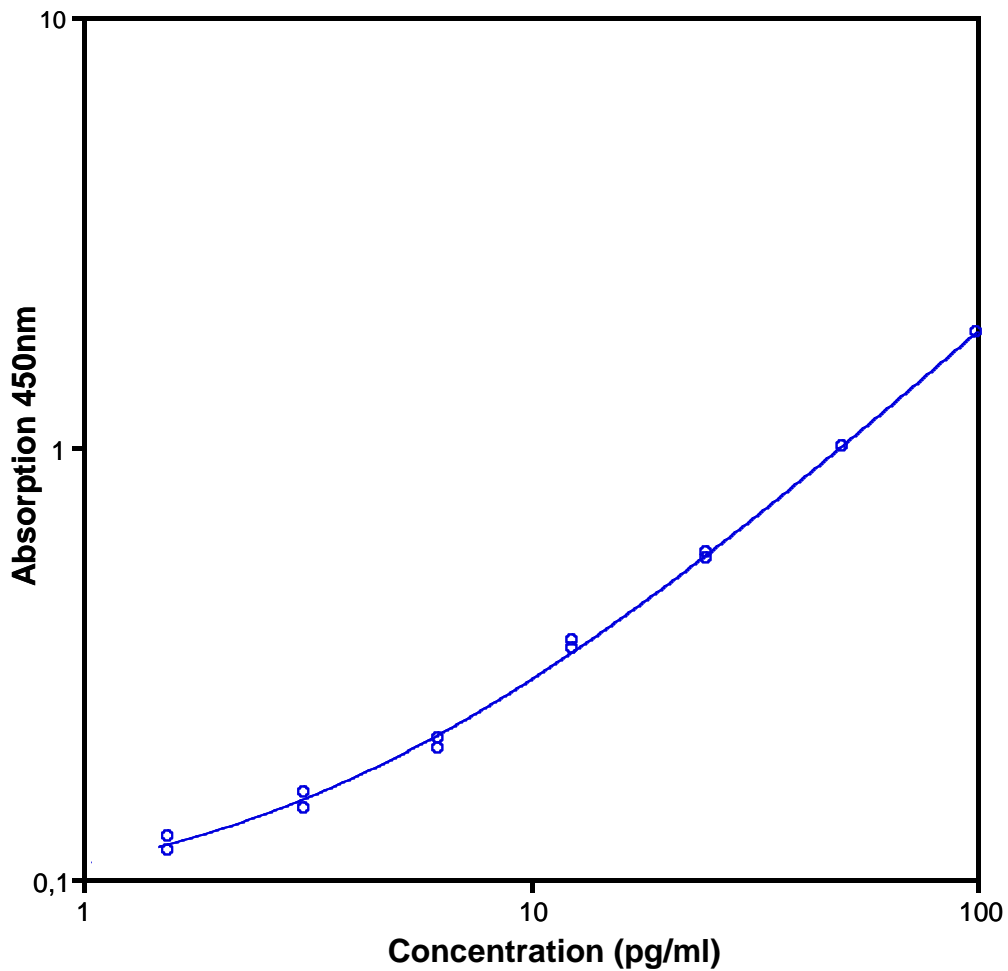

Table 2

Typical data using the human IL-6 ELISA

Measuring wavelength: 450 nm

Reference wavelength: 620 nm

Standard	Human IL-6 Concentration (pg/ml)	O.D. (450 nm)	O.D. Mean	C.V. (%)
1	100.00	1.848 1.854	1.851	0.2
2	50.00	1.005 1.002	1.004	0.2
3	25.00	0.553 0.570	0.562	2.1
4	12.50	0.355 0.343	0.349	2.4
5	6.25	0.201 0.212	0.207	3.8
6	3.13	0.146 0.158	0.152	5.6
7	1.56	0.116 0.125	0.121	5.3
Blank	0	0.075 0.086	0.081	

The OD values of the standard curve may vary according to the conditions of assay performance (e.g. operator, pipetting technique, washing technique or temperature effects). Furthermore shelf life of the kit may affect enzymatic activity and thus colour intensity. Values measured are still valid.

12 Limitations

- Since exact conditions may vary from assay to assay, a standard curve must be established for every run.
- Bacterial or fungal contamination of either screen samples or reagents or cross-contamination between reagents may cause erroneous results.
- Disposable pipette tips, flasks or glassware are preferred, reusable glassware must be washed and thoroughly rinsed of all detergents before use.
- Improper or insufficient washing at any stage of the procedure will result in either false positive or false negative results. Empty wells completely before dispensing fresh wash solution, fill with Wash Buffer as indicated for each wash cycle and do not allow wells to sit uncovered or dry for extended periods.
- The use of radioimmunotherapy has significantly increased the number of patients with human anti-mouse IgG antibodies (HAMA). HAMA may interfere with assays utilizing murine monoclonal antibodies leading to both false positive and false negative results. Serum samples containing antibodies to murine immunoglobulins can still be analysed in such assays when murine immunoglobulins (serum, ascitic fluid, or monoclonal antibodies of irrelevant specificity) are added to the sample.

13 Performance Characteristics

13.1 Sensitivity

The limit of detection of human IL-6 defined as the analyte concentration resulting in an absorbance significantly higher than that of the dilution medium (mean plus 2 standard deviations) was determined to be 0.92 pg/ml (mean of 6 independent assays).

13.2 Reproducibility

13.2.1 Intra-assay

Reproducibility within the assay was evaluated in 2 independent experiments. Each assay was carried out with 6 replicates of 8 serum samples containing different concentrations of human IL-6. 2 standard curves were run on each plate. Data below show the mean human IL-6 concentration and the coefficient of variation for each sample (see Table 3). The calculated overall intra-assay coefficient of variation was 3.4%.

Table 3

The mean human IL-6 concentration and the coefficient of variation for each sample

Sample	Experiment	Mean Human IL-6 Concentration (pg/ml)	Coefficient of Variation (%)
1	1	40.7	7.8
	2	42.2	1.6
2	1	40.1	4.1
	2	40.1	2.6
3	1	43.2	1.1
	2	41.7	3.5
4	1	65.6	2.3
	2	65.4	4.6
5	1	47.2	1.6
	2	48.0	2.1
6	1	34.1	2.5
	2	37.8	5.4
7	1	27.3	0.2
	2	35.2	7.7
8	1	37.8	4.1
	2	42.6	2.4

13.2.2 Inter-assay

Assay to assay reproducibility within one laboratory was evaluated in 2 independent experiments. Each assay was carried out with 6 replicates of 8 serum samples containing different concentrations of human IL-6. 2 standard curves were run on each plate. Data below show the mean human IL-6 concentration and the coefficient of variation calculated on 18 determinations of each sample (see Table 4). The calculated overall inter-assay coefficient of variation was 5.2%.

Table 4

The mean human IL-6 concentration and the coefficient of variation of each sample

Sample	Mean Human IL-6 Concentration (pg/ml)	Coefficient of Variation (%)
1	41.5	2.6
2	40.1	0.0
3	42.5	4.4
4	65.5	0.2
5	47.6	1.2
6	35.9	7.3
7	31.3	17.8
8	40.2	8.4

13.3 Spike Recovery

The spike recovery was evaluated by spiking 4 levels of human IL-6 into serum. Recoveries were determined in 2 independent experiments with 8 replicates each.

The unspiked serum was used as blank in these experiments.

The recovery ranged from 78% to 105% with an overall mean recovery of 88%.

13.4 Dilution Parallelism

Serum samples with different levels of human IL-6 were analysed at serial 2 fold dilutions with 4 replicates each.

The recovery ranged from 98% to 111% with an overall recovery of 105% (see Table 5).

Table 5

Sample	Dilution	Expected Human IL-6 Concentration (pg/ml)	Observed Human IL-6 Concentration (pg/ml)	Recovery of Expected Concentration (%)
1	1:2	--	46.4	--
	1:4	23.2	22.7	98
	1:8	11.6	11.8	102
2	1:2	--	95.0	--
	1:4	47.5	50.3	106
	1:8	23.8	23.4	99
3	1:2	--	51.9	--
	1:4	26.0	28.8	111
	1:8	13.0	14.4	111

13.5 Sample Stability

13.5.1 Freeze-Thaw Stability

Aliquots of serum samples (unspiked or spiked) were stored at -20°C and thawed 5 times, and the human IL-6 levels determined. There was no significant loss of human IL-6 immunoreactivity detected by freezing and thawing.

13.5.2 Storage Stability

Aliquots of serum samples (spiked or unspiked) were stored at -20°C, 2-8°C, room temperature (RT) and at 37°C, and the human IL-6 level determined after 24 h. There was no significant loss of human IL-6 immunoreactivity detected during storage under above conditions.

13.6 Comparison of Serum and Plasma

From two individuals, serum as well as EDTA, citrate and heparin plasma obtained at the same time point were evaluated. Human IL-6 concentrations were not significantly different and therefore all these body fluids are suitable for the assay. It is nevertheless highly recommended to assure the uniformity of blood preparations.

13.7 Specificity

The interference of circulating factors of the immune system was evaluated by spiking these proteins at physiologically relevant concentrations into a human IL-6 positive serum. There was no crossreactivity detected.

13.8 Expected Values

A panel of samples from randomly selected apparently healthy donors (males and females) was tested for human IL-6. The levels measured may vary with the sample collection used. For detected human IL-6 levels see Table 6.

Table 6

Sample Matrix	Number of Samples Evaluated	Range (pg/ml)	% Detectable	Mean of Detectable (pg/ml)
Serum	40	nd *- 12.7	47.5	5.8
Plasma (EDTA)	40	nd *- 13.0	17.5	6.4
Plasma (Citrate)	40	nd *- 6.6	2.5	6.6
Plasma (Heparin)	40	nd *- 6.5	30.0	5.0

* n.d. = non-detectable, samples measured below the lowest standard point are considered to be non-detectable.

13.9 Calibration

The immunoassay is calibrated with highly purified recombinant human IL-6 which has been evaluated against the international Reference Standard NIBSC 89/548 and has been shown to be equivalent. NIBSC 89/548 is quantitated in International Units (IU), 1IU corresponding to 10 pg human IL-6.

14 Ordering Information

North America

Technical Support:

Research Products:
888.810.6168
858.642.2058
tech@eBioscience.com

Clinical Products:
877.726.8559
858.642.2058
tech@eBioscience.com

Customer Service:

888.999.1371
858.642.2058
info@eBioscience.com

Fax:

858.642.2046

Europe/International*

Technical Support:

+43 1 796 40 40-120
tech@eBioscience.com

Customer Service:

+43 1 796 40 40-305
info@eBioscience.com

Fax:

+43 1 796 40 40-400



Bender MedSystems GmbH
Campus Vienna Biocenter 2
1030 Vienna, Austria
www.eBioscience.com

* Customers outside North America and Europe may contact their eBioscience distributor listed on our website at www.eBioscience.com/distributors.

15 Reagent Preparation Summary

15.1 Wash Buffer (1x)

Add **Wash Buffer Concentrate 20x** (50 ml) to 950 ml distilled water.

Number of Strips	Wash Buffer Concentrate (ml)	Distilled Water (ml)
1 - 6	25	475
1 - 12	50	950

15.2 Assay Buffer (1x)

Add **Assay Buffer Concentrate 20x** (5 ml) to 95 ml distilled water.

Number of Strips	Assay Buffer Concentrate (ml)	Distilled Water (ml)
1 - 6	2.5	47.5
1 - 12	5.0	95.0

15.3 Biotin-Conjugate

Make a 1:100 dilution of **Biotin-conjugate** in Assay Buffer (1x):

Number of Strips	Biotin-Conjugate (ml)	Assay Buffer (1x) (ml)
1 - 6	0.03	2.97
1 - 12	0.06	5.94

15.4 Streptavidin-HRP

Make a 1:200 dilution of **Streptavidin-HRP** in Assay Buffer (1x):

Number of Strips	Streptavidin-HRP (ml)	Assay Buffer (1x) (ml)
1 - 6	0.03	5.97
1 - 12	0.06	11.94

15.5 Human IL-6 Standard

Reconstitute lyophilized **human IL-6 standard** with distilled water. (Reconstitution volume is stated on the label of the standard vial.)

15.6 Controls

Add 300 µl distilled water to lyophilized **controls**.

16 Test Protocol Summary

1. Determine the number of microwell strips required.
2. Wash microwell strips twice with Wash Buffer.
3. Standard dilution on the microwell plate: Add 100 µl Assay Buffer (1x), in duplicate, to all standard wells. Pipette 100 µl prepared standard into the first wells and create standard dilutions by transferring 100 µl from well to well. Discard 100 µl from the last wells.
Alternatively external standard dilution in tubes (see 9.5.1): Pipette 100 µl of these standard dilutions in the microwells.
4. Add 100 µl Assay Buffer (1x), in duplicate, to the blank wells.
5. Add 50 µl Assay Buffer (1x) to sample wells.
6. Add 50 µl sample in duplicate, to designated sample wells.
7. Prepare Biotin-Conjugate.
8. Add 50 µl Biotin-Conjugate to all wells.
9. Cover microwell strips and incubate 2 hours at room temperature (18° to 25°C).
10. Prepare Streptavidin-HRP.
11. Empty and wash microwell strips 4 times with Wash Buffer.
12. Add 100 µl diluted Streptavidin-HRP to all wells.
13. Cover microwell strips and incubate 1 hours at room temperature (18° to 25°C).
14. Empty and wash microwell strips 4 times with Wash Buffer.
15. Add 100 µl of TMB Substrate Solution to all wells.
16. Incubate the microwell strips for about 10 minutes at room temperature (18° to 25°C).
17. Add 100 µl Stop Solution to all wells.
18. Blank microwell reader and measure colour intensity at 450 nm.

Note: If instructions in this protocol have been followed, samples have been diluted 1:2 (50 µl sample + 50 µl Assay (1x)) and the concentration read from the standard curve must be multiplied by the dilution factor (x 2).