

SINNOWA[®]

**DS-161 Fully Automatic Biochemistry Analyzer
User's Manual**

SINNOWA MEDICAL SCIENCE & TECHNOLOGY CO.,LTD.

Introduction

Thank you for choosing SINNOWA DS-161 Fully automatic biochemistry analyzer. Please read enclosed user manual carefully before installing machine. Sinnowa will reserve right to make any update for machine without prior notice, please browse our website www.sinnowa.com to get the latest information.

Any questions please don't hesitate to contact local distributor or Sinnowa customer service department.

Attention

- The machine should be operated by professionals.
- Well-done daily maintenance will keep DS-161 in good working conditions.
- Sinnowa won't take charge of any damages due to wrong operation and wrong maintenance.
- Sinnowa reagents are recommended to get better testing results.
- Quality control testing is necessary to do every day. It will be helpful for watching machine working status.

After sale service: Sinnowa Medical Science & Technology Co., Ltd

Address: No.7 Bao Shan Rd., Qilin Industrial Park, Nanjing, China

Z.P: 211135

Tel.: 0086-025-84127928, 84127188 extension 8304,8306

Fax: 0086-025-84127199

Website: <http://www.sinnowa.com>

Mailbox: info@sinnowa.com

DIRECTORY

Chapter 1 Brief Introduction of the Manual	1
1.1 Range of the manual	1
1.2 Icon	1
1.3 The explanation of option operation.....	3
Chapter 2 INTRODUCTION OF THE ANALYZER.....	4
2.1 Introduction	4
2.2 The principle.....	4
2.3 Applicability	4
2.4 Components for the analyzer.....	4
2.5 Basic technical specifications.....	5
2.6 Alarm indications	7
2.7 Main structures.....	7
Chapter 3 INSTALLATIONS.....	8
3.1 Requirements of installations.....	8
3.1.1 Requirements of space	8
3.1.2 Power	8
3.1.3 Working environment.....	9
3.2 Open package	9
3.2.1 Steps.....	9
3.3 Steps of installations.....	10
3.3.1 Remove the foam to fix the probe.....	11
3.3.2 Installation of cuvettes.....	11
3.3.3 Connections of the pipelines	11
3.3.4 Connections of the equipment.....	13
<i>Don't pull and plug electriferous serial port cable.</i>	14
Chapter 4 INSTALLATIONS OF SOFTWARE.....	15
4.1 Requirements of installations.....	15
4.1.1 Requirements of computer configuration	15
4.1.2 Requirements of system environment.....	15
4.2 The steps of installations.....	16
Chapter 5 FUNCTIONAL MENU OF SOFTWARE.....	18
5.1 Files in software folder	18
5.2 Run software	19

5.3 Function menu list	19
5.4 Files	20
5.4.1 Log off	20
5.4.2 Print report setup	20
5.4.3 Print report	21
5.4.4 Exit	21
5.5 View	22
5.5.1 Full screen	22
5.5.2 Navigation	22
5.5.3 Title bar	61
5.5.4 Monitoring	61
5.5.6 Language	63
5.6 Item	65
5.6.1 Biochemistry item setup	65
5.6.2 Q.C. item setup	80
5.6.3 Calculate item setup	81
5.6.4 Print item setup	82
5.6.5 Pollution clean item setup	83
5.6.6 Reagent setup	84
5.6.7 Other setup	85
5.6.8 "One button" combination action setup	93
5.6.9 Blank display	95
5.7 Task	96
5.7.1 Add sample	96
5.7.2 Add standard	96
5.7.3 Add Q.C.....	96
5.8 Test	96
5.8.1 Biochemistry test	96
5.8.2 Blank test	96
5.8.3 Stat and check reagent	96
5.9 Result	97
5.9.1 Sample result.....	97
5.9.2 Calibration result	97
5.9.3 Q.C. result	98
5.9.4 Results analysis	98
5.9.5 Item result	99
5.9.6 Send result	99
5.10 Device	99
5.10.1 Device maintenance	99
5.10.2 Force stop test	99
5.10.3 Pause test	100

5.10.4 Action test	100
5.10.5 Device parameters	101
5.11 Help.....	110
5.11.1 Help	110
5.11.2 Important information	111
5.11.3 About ABA.....	111
5.11.4 Apply license	112
5.11.5 Load license.....	113
5.11.6 Browse license.....	113
6.1 Turn the analyzer on.....	115
6.2 Routine maintenance	115
6.3 Blank test	116
6.4 Add sample, control and standard	116
6.5 Test.....	117
6.6 Print the test result	118
6.7 Routine maintenance	118
6.8 Turn off the analyzer.....	118
<i>Chapter 7 REAGENT, SAMPLE, DETERGENT, CONTROL AND CALIBRATION.....</i>	<i>120</i>
7.1 Reagent.....	120
7.2 Sample disposal	120
7.3 Detergent.....	120
7.4 Control	121
7.5 Calibration.....	122
<i>Chapter 8 DEVICE MAINTENANCE</i>	<i>123</i>
8.1 Daily maintenance	123
8.2 Weekly maintenance	124
8.3 Monthly maintenance.....	124
8.4 Quarter- maintenance	125
<i>Chapter 9 TROUBLESHOOTING</i>	<i>126</i>
9.1 Malfunction phenomenon and maintenance	126
9.2 Corrections and replacements for common parts of the analyzer	138
9.2.1 The replacement to lamp	138
9.2.2 The replacement for the piston of injector	139
9.2.3 The replacement to probes	141
9.2.4 The replacement to cuvettes	142

9.2.5 The replacements to fuse.....	142
9.2.6 Adjustments for GAIN & OFFSET.....	143
10.1 Transportation	147
10.2 Storage	147
<i>Appendix 1: Manual scanner installation and application.....</i>	<i>148</i>
F1.1 Installation.....	148
F1.2 Manual scanner application.....	151
F1-3 Built-in scanning setup.....	153
F1-4 Barcode read	155
F1-5 Start measuring.....	158
<i>Appendix 2 The process of installation.....</i>	<i>159</i>
<i>Appendix 4 Component List.....</i>	<i>161</i>
In order to ensure that the instrument can normal work and get good reliable test results, the following the components of the instrument are supplied by our company.	161

Chapter 1 Brief Introduction of the Manual

The contents of DS-161 Fully automatic biochemistry analyzer user manual include working principle, software introduction, maintenance guide and trouble shooting, please read it carefully



- Please operate it strictly with instruction of the manual.
- In this manual, it gives all the necessary information for the model of DS-161 Fully Automatic Biochemistry Analyzer.

1.1 Range of the manual



The manual will help the operators who have laboratory medical science and biochemistry basic knowledge to know work principles and hardware, software installation, daily operations, maintenance and resolve for common troubles etc.

1.2 Icon

Icons and indications in the manual: follows as Table 1-1

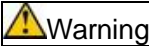
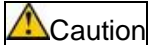

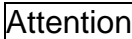





Table 1-1

Denotations	Indications
 Warning	Pay more attention to current operation, otherwise it may damage the operator or analyzer
 Caution	Pay more attention to current operation, otherwise it may cause some malfunctions, damage, or discrepancies to the test result.

	<p>Pay more attention to some important information and steps.</p>
	<p>Pay more attention to current operation, otherwise it may cause a potential biological risk.</p>

Icon and indications with the analyzer see Table 1-2

Table 1-2

Denotations	Indications
	ON (general power)
○	OFF (general power)
ON	ON (power)
OFF	OFF (power)
	Ground connection (ground)
	Protection of ground connection (ground)
	Caution! Read attached document.
	Biological risk
	Caution! Electric shock risk
~	AC
	Application of style B
IVD	In vitro diagnostics devices
CE	CONFORMITE EUROPEENNE
	Date of manufacture
SN	Series number of equipment
	No touching ,otherwise, maybe damage to operators or the equipment

1.3 The explanation of option operation

1) Optional operations in the items

r_GT : Chosen

r_GT : Not chosen

ALT : Invalidation or add samples is finished

2) Optional operations in the installations of the parameter

: Chosen

: Canceled

Chapter 2 INTRODUCTION OF THE ANALYZER

2.1 Introduction

DS-161 Fully Automatic Biochemistry Analyzer is adequate for measuring, analyzing for chemical and fix quantity of biochemistry in the blood serum and urine under lab circumstance, a outer body diagnose equipment which is used for clinic diagnose and science research. The series uses current international mainstream separate structures, and each model with automatic washing equipments, besides many patents are used, so they have perfect functions and test results are more reliable.

2.2 The principle

Lambert-Beer law

An incident wave, shooting solution that holds a substance with homogeneous concentration, respects this law through its path inside the solution:

2.3 Applicability

Used for biochemical indicators testing of the body fluid and also for animals.

2.4 Components for the analyzer

Main components of the analyzer:

Reagent/Sample plates

One reagent plate, one sample plate.

The reagent plate with refrigerated function.

Add samples and reagent system

Add probe/reagent probe, add arm/reagent arm, high precision diluter, and corresponding pipelines ect.

Measuring system:

With light source, filters, cuvettes, quartz glass fiber and detection board etc.

Or with light source ,grating, cuvettes, and detection board etc (optional)

With main control circuits, detection circuits, drive circuits, motors/pumps/valves, position-monitoring systems etc.

Cuvettes washing system:

Clean tips, influent tubes, pumps, valves, and drainage tubes etc

Machinery structures/parts of out housing:

With machine transmission, brake, support/fixed structures and out housing.

External components: With computers and printers etc.

2.5 Basic technical specifications

Assay method: End-point, Kinetic, two points, multi-standard, bichromatic, serum Blank, immunoturbidimetric etc.

Assay item: 40 or up to 80 items.(with 80 reagent bottles).

Programmed item: 2000 test items at least.

Sample plate: DS-161 with one sample plate
Sample position includes stat, control and standard.

Reagent plate : 1 reagent plate for DS-161

Sample volumes: 1uL~100μL ;

Reagent volumes: 1uL~400μL ;

Min. reaction volumes:180ul;

Max. throughput: DS-161 160Test/H;

Emergency functions: Insert stat sample, standard sample, and quality control sample at any time.

Calibration: Linear, nonlinear, one- point and multi-point.

Control: Each item has many controls.

Optical systems:

❖ Measured filter setup (nm): DS-161 with 8 one, more 2 available on request.

❖ Filter station: 340nm, 405nm, 450nm, 505nm, 546nm, 578nm, 620nm, 670 nm ,

Choose waves: 380nm, 492 nm, 630nm, 650 nm, 660nm, 700nm, 810nm.

❖ Grating(optional) : 340,405,450,480,505,546,570,600,660,700,750,800 nm.

❖ Lamp: 12V20W halogen

❖ Measuring detector:

With 8 high sensitivity and photoelectric receptors, and more 2 ones available.

Linearity range: 0.0000A~3.000A;

Absorbency:0.0000~4.0000A; (Max. absorbency 5.0000A for 6 mm cuvettes)

The precision of absorbency: 0.0001A;

Repetition of absorbency: coefficient variance (CV)≤1.0%;

Stability of absorbency: Less than 0.005A within 20mins at 340nm

Temperature controls: 37°C.for reaction cuvette.

The environment temperature is 18-25 °C

Reaction cuvettes: Through ultraviolet, visible plastic cup or quartz glass

Data processing:

Calculation of parameter, calibration of blank cuvette, setup of item parameter and storage of result tested, data enquiry, management of quality control, inspection of reaction curve for whole reaction period, and edit results report etc.

Storage: Store more than 100,000 information of patients and can be enlarged base on hard disk of computers.

Print: Print reports with different styles and users can edit them by themselves.

Dilution/retest: Retest samples automatically once the result is beyond linear range.

Users also can set dilution or retest.

Add samples/ detecting of reagent probes:

With liquid level detecting, detect remaining volumes for reagent in the reagent bottle automatically with track function with volumes

Supply power: 220V~, 50/60Hz; or 110V~, 60Hz;

Fuse: T8AL250V,Φ5x20(mm);

Power: 1200 VA.

ISE : optional

Barcode: optional

2.6 Alarm indications

Four lights on the front panel of the analyzer indicating from left to right:

power, reagent cool, shortage of water and overflow waste liquid.

The first green light is on; it means the equipment is turned on.

The second green light is on; it means the refrigerator is running.

The third red light is on with buzz, it means the equipment is absent of water.

The fourth red light is on with buzz, it means the equipment is full of waste liquid.

If temperature of reaction plate exceeds 50°C, the equipment will buzz.

2.7 Main structures

Main structures of the analyzer please see Form 2-1.

Item	Max. throughput	Reagent plates	Reagent/sample probes	Sample plates	Anti-collision function for sample probes	wavelengths
DS-161	160t/h	1 with sample plate	1	1 with reagent plate	Yes	standard 8 pcs optional 2 pcs

Chapter 3 INSTALLATIONS

In order to ensure the equipment can run normally, it must be installed and debugged by engineers of SINNOWA or authorized engineers by training department of SINNOWA.

The analyzer must be reinstalled for being move or used in remote places

Attention :

- The equipment must be installed by the engineer who are trained or authorized by SINNOWA. Otherwise, no permitting installation may damage to the equipment. The damage is not in the free warranty scope for SINNOWA.

3.1 Requirements of installations

Meet requirements for space, power supply and working environment before installation.

3.1.1 Requirements of space

To ensure enough space for releasing heat, repairing and maintenance, and pipes behind the equipment are not squeezed, liquid can flow normally; it must meet requirement as follows:

1. Keep not less than 100 mm distance between the wall and other objects for each side (left, right and back) of the analyzer.
2. Ensure enough space for the equipment to place barrel of distilled water and waste container.
3. Ensure enough space to place the computer on the desk, and the distance between computer and equipment is 100mm at least.

3.1.2 Power

1. 220±22 V~ , 50±1Hz OR 110±11V~, 60±1Hz
2. When 110V is used, the adapter has to adjust to 110V.

3. A good grounding socket within 1 meter to supply power for the equipment.

Attention :

- The equipment needs to be connected with a socket within 1 meter in order to pull out the plug timely under urgent conditions.
- Check if network voltage is the same to the equipment voltage before using.

3.1.3 Working environment

1. Working temperature: 10°C ~ 30°C;
2. Working humidity: 30% ~ 80%;
3. Working atmospheric pressure: 86KPa ~ 106 KPa;
4. The environment should keep away from dust, noise and interference of power;
5. The equipment should be far away from interference source of strong electricity, magnetic e.g.: CT, X-ray machine, Centrifuge;
6. Avoid direct sunlight and ultraviolet rays and keep away from hot and entrance of cold source e.g.: air condition;

3.2 Open package

3.2.1 Steps

Before opening the package, please check whether there is something wrong with it. If the package is broken, wet or polluted, please do not open it and contact immediately with the carrier and local dealers. If outer is not damaged, please open it as following steps:

1. Unpack the package carefully, check annex list one by one. If there is anything missed, please contact with the service department of SINNOWA or local dealers.
2. Choose an appropriate position to place it well and ensure the table-board is level.

3. Take out the fixing foam and then the analyzer, remove the packing film. Then, place the analyzer on the level table of cabinet. And the equipment and the cabinet are in proper place.



:

- Check carefully to ensure all the plugs are connected well before switching on.
- Ensure working table is horizontal and steady.



- The analyzer with good grounding condition to use.
- To avoid the voltage's waving, please install voltage regulator (user owning) to ensure stability and reliability for test result.
- Interrupted power often will affect the reliability of the equipment, lose test data or damage the analyzer. So if the local electricity supply is frequently interrupted, UPS (user owning) must be used.
- Ensure power button is off before it is connected.
- Appointed fuse to be used for the analyzer.
- The distance between table-board and the equipment's bottom is very narrow. Open two front doors of the cabinet before placing the analyzer. Your hands should be placed before and after the analyzer. Otherwise, maybe your hands are squeezed.

3.3 Steps of installations



- ❖ In order to avoid hurting during the operation, the operator must pay attention to keep your cloth, hair and some sporting goods away from the analyzer.

- ❖ The probe perhaps carries with some blood serum, standard sample and quality control sample. And used reagents have potential biological risk. Therefore, it is dangerous to touch the probe directly.

3.3.1 Remove the foam to fix the probe

The analyzer must fixed foam to avoid damage during transportation. Remove foam before using. Operations as follows:

1. Lift up the reagent arm and/or sample arm.
2. Remove adhesive tape around the arm and the foam.
3. Move arms to make probes to washing cell

Attention

The probe position may be changed during transportation or installation. Thus, it is necessary to check whether probes are being placed in the centre

3.3.2 Installation of cuvettes

Take out cuvettes from accessories box carefully, not to touch window surface; place them well in the reaction plate to be sure all cuvettes are at the same level and well fixed.

Attention

- The front and back sides of the cuvettes are detection of surface. Please don't touch them before placing cuvettes.
- Place cuvettes and ensure top surfaces are horizontal. Otherwise, it is easy to keep some residue water in the cuvettes, so that it will affect results.

3.3.3 Connections of the pipelines

Every junction of liquid pipelines is installed with a protective cover to avoid being polluted

from liquid during transportation. Remove covers and ensure each tube and each junction both have no external object before connection. Besides.

Please refer to Figure 3-1 Steps as follows:

1. Take out catheters and waste liquid tubes.
2. Connect the high pollution waste liquid tie-in of the the analyzer to high pollution waste liquid barrel .connect the waste liquid tie-in of analyzer to common waste liquid barrel and fix waste liquid probe in it. All connections need to be connected in the light of the principle of the same color.
3. Fix one side of the tube on analyzer and plunge the other side connected with heavy block into barrel.
4. Place tubes and probes of shortage of water at the bottom of barrel of distilled water.

Pipeline graphics (inside model)

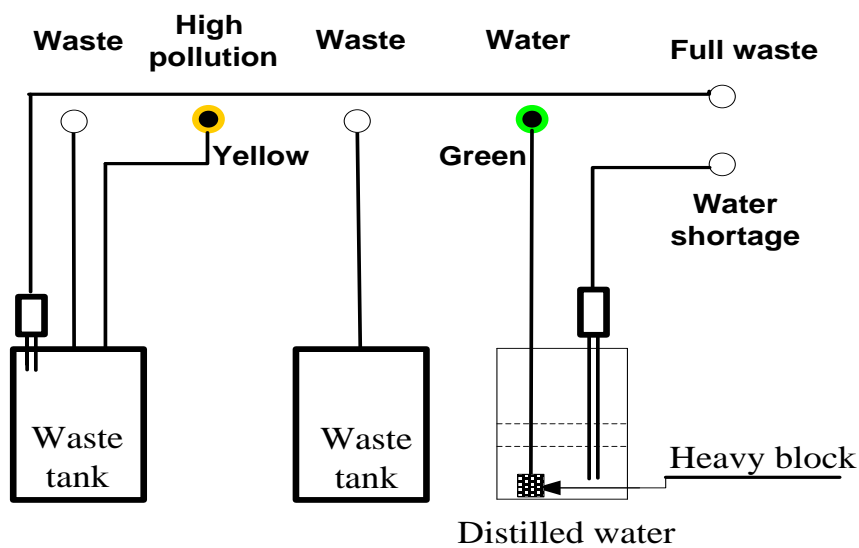

Figure 3-1

Attention

- Ensure pipelines and joints both have no scrap before connection. Otherwise, it is easy to damage pumps and valves.
- The heavy block of pipelines is used to avoid the tube from floating to ensure accuracy of test.

- Don't bend the waste liquid tube or immerse it in waste liquid. Please cut off too long tubes. Otherwise, it will cause poor drainage and waste water of washing cup will overflow.
- This figure just for reference, subject to the label.



- The equipment with 3 waste liquid exits. One is high concentration waste liquid; the other exits are low concentration waste liquid. Collecting them separately is convenient to protect environment. Suggest the high concentration waste liquid should be discharged after harmless treatment, but do not pour it into sewer directly.

3.3.4 Connections of the equipment

Please refer to Figure 3-2. Steps as follows:

1. Take out power table and RS232 cable from accessory case.
2. Adjust voltage adapter of the analyzer according to network 220V or 110V. (defaulted 220V)
3. Connect the computer's COM1 to the serial port of mainframe with RS232 series cable and fixed.
4. Connect to printer.

Attention

1. If bar code scanner need to be installed , please see Appendix I
2. Please install higher version driver, if printer doesn't support figures and words.
3. This figure just for reference, please refer to label connect cable.

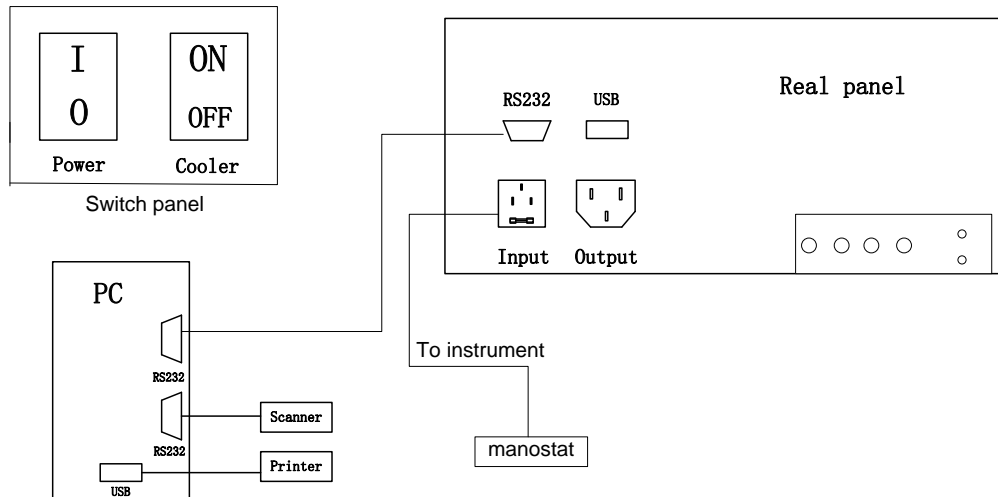

Figure 3-2

Warning

- Supply power needs the same voltage as the input power mark of the switch box. Otherwise, it may cause damage to the equipment.
- The protection ground point of the analyzer must be firmly grounded.

Don't pull and plug electriferous serial port cable.

Chapter 4 INSTALLATIONS OF SOFTWARE

In order to assure the software can run normally, the analyzer is installed and set parameters by engineers or authorized engineers of SINNOWA. When change the original computer, the equipment must be installed and set by the process of installations.

4.1 Requirements of installations

Only meet following requirements for computer configuration and system environment, and then the equipment can be installed.

4.1.1 Requirements of computer configuration

In order to ensure the computer can store data and run normally, it must meet conditions as follows:

CPU: p4 or over

Memory: 1G or above

CD-ROM: 52

Graphics card: 64M or above,

Hard disk: 40G or above

Serial port: provide 2 serial ports, which runs steadily

Modem: 56k

Speaker: active speaker

4.1.2 Requirements of system environment

In order to ensure software runs well, system environment should meet the requirements as follows:

For ensuring software runs well, system environment should meet requirements as follows:

1. Operating system is windows 2000 or windows XP ,VISTA
2. Suggestion: System need install the software of Microsoft Office Access in advance.
3. Suggestion: Install decompression software (winrar tool).

4.2 The steps of installations

1. Insert the CD-ROM with the analyzer into CD drive.
2. Seek for the software of DS-161, copy it to D disk and get rid of the read-only attribute of document.
3. Installation Setup software, as shown in Figure 4-1

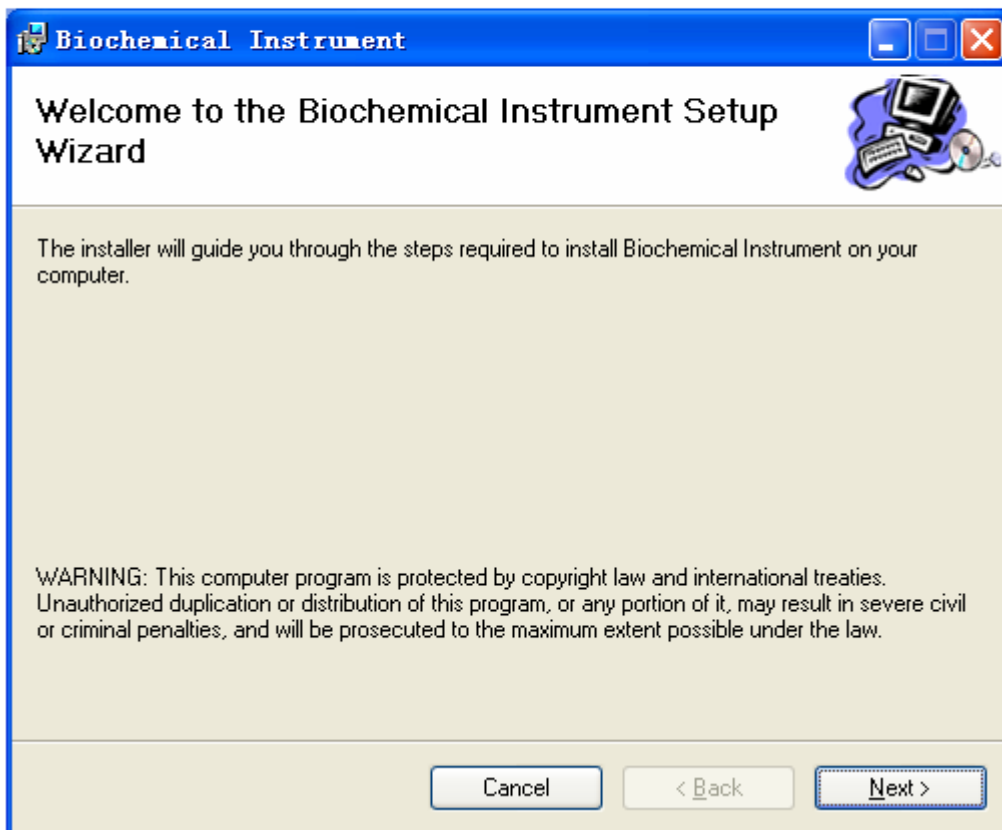

Figure 4-1

4. Click the "next", as shown in figure 4-2:

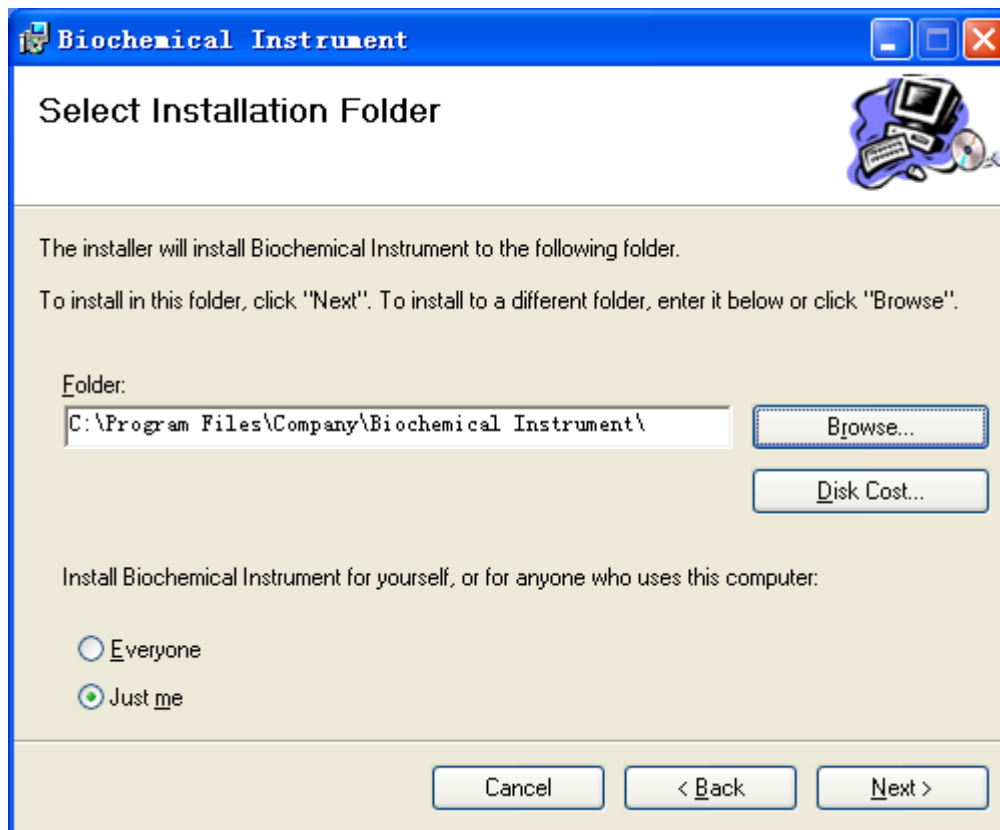

Figure 4-2

5. According to steps, exit the software installation. Then the desktop appear in a



6. According to normal installation steps, then operating software.

Chapter 5 FUNCTIONAL MENU OF SOFTWARE

5.1 Files in software folder



: Main software



: Mechanical parameters



: Database recover



: Cuvette water blank data



: Edit print format

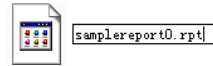

: Print report template



: Database



: Setup display rows



: English manual



: Language file



:

DataBackup is called Hardwarebak.ini for saving and recovering defaulted hardware parameters, If customers make mistakes or parameters go wrong, for recovering them, please use: “hardware parameter restore” password: 888, please don’t use this function randomly. Please refer to Figure 5-1,

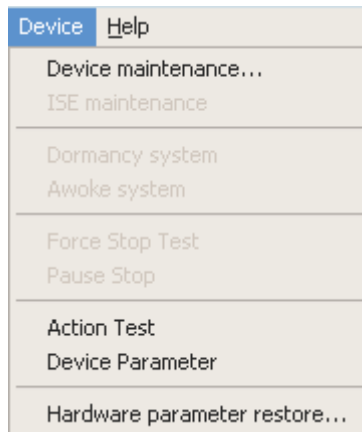



Figure 5-1



Warning

- This operation for administrators only; otherwise, SINNOWA is not responsible for any wrong operation!
- Any compilation “Hardwarebak” in Data Backup is forbidden.

5.2 Run software

Double click “ DJABA.exe
ABA MFC Application” it will be seen Figure.5-2

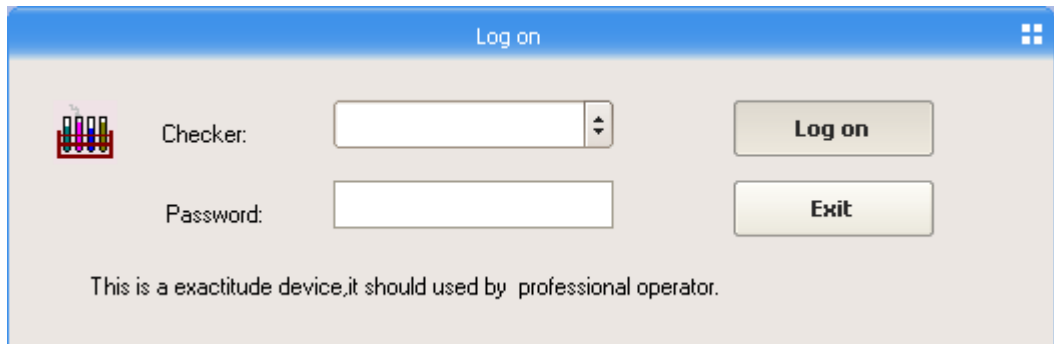

Figure.5-2

After logging on, input checker: “admin” , password: “admin” , main interface will be shown.

Attention :

- Software interface could be different owing to the software is upgraded, so please refer to what you are using.

5.3 Function menu list

The structures of the menu please see: Figure 5-3

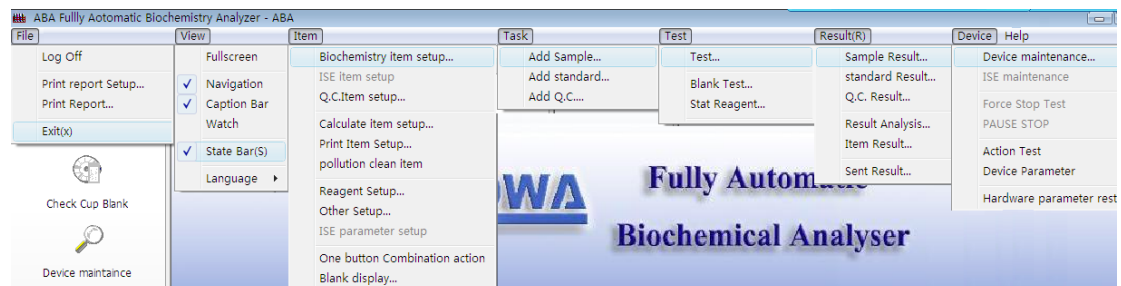

Figure 5-3

5.4 Files

5.4.1 Log off

Log off means operators leave original operation and others will log on.

The system will show Figure 5-4 after clicking.

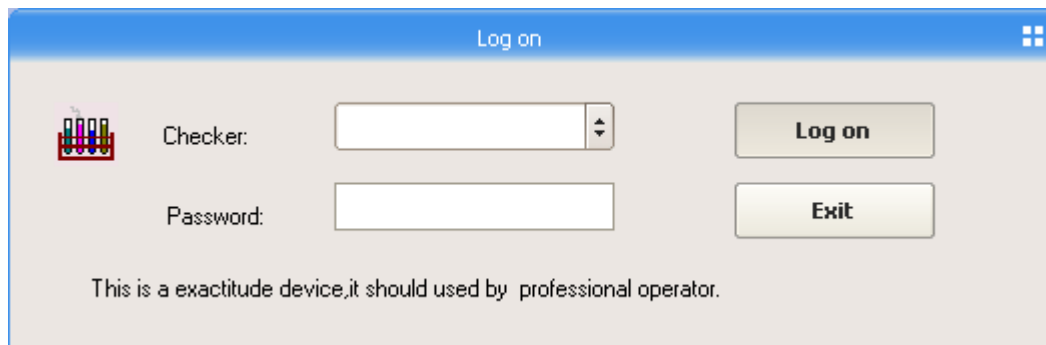

Figure 5-4

First of all, choose name of checker “admin” and then input password “admin”; click “log on,” If click “Exit,” the system will be returned to dialog box.

Attention

- If the system is logged on by certain checkers to test results, whose name will be appeared in the print report.

5.4.2 Print report setup

Print report setup is used for setting attribute of printer, size of paper etc.

The system appears as Figure 5-5 shown after clicking.

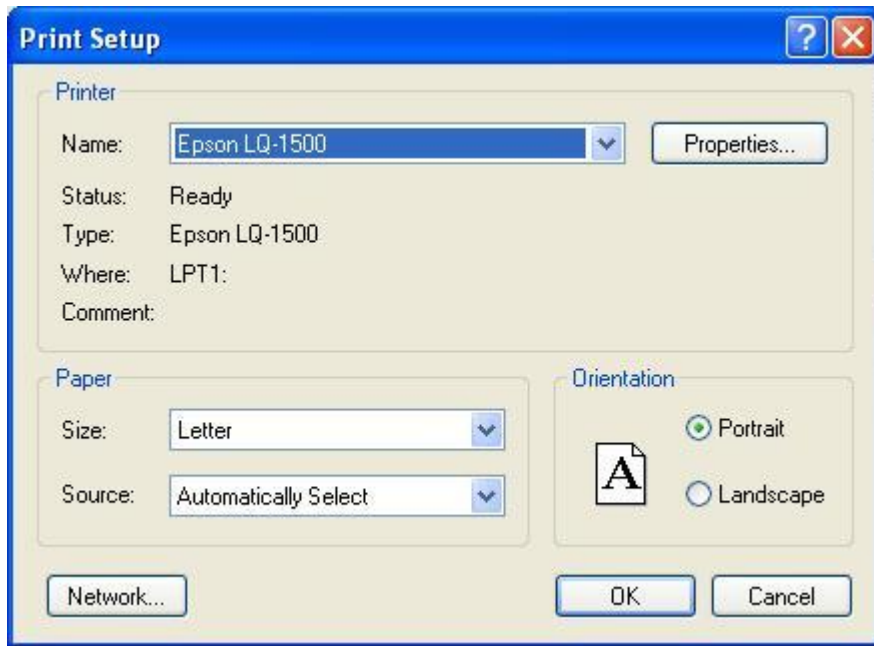

Figure 5-5

Set them well and click “OK” button.

5.4.3 Print report

“Print result” window will appear after clicking. It’s convenient for user to input and store sample information and print report. Please refer to 5.5.2.3.1.

5.4.4 Exit

Click “Exit”, if the system doesn’t reset, and gives a hint: “Force to exit would lose data.....”

Attention

- Please reset before exiting the software.

5.5 View

5.5.1 Full screen

Software window is displayed in the form of full screen.

5.5.2 Navigation

Add daily menus to task navigation on the left. In order to operate it easily, you can enter the main menu.

5.5.2.1 Device run

It is convenient to use testing functions, cuvettes water blank value and equipment maintenance.

5.5.2.1.1 Test

Please prepare for samples, control samples and calibration samples before test.

Click main menu "Test/Biochemistry test" or task navigation "Device run/Biochemistry test, then the system will appear a window as Figure 5-6 shown.

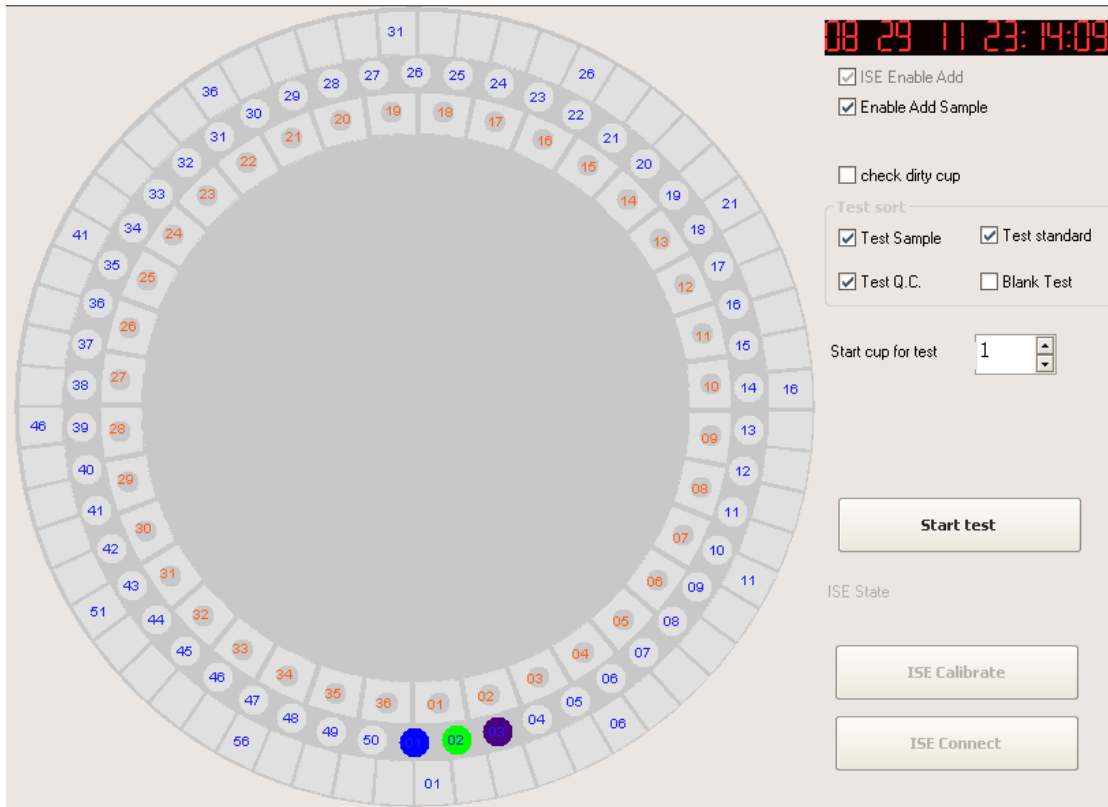

Figure 5-6

The system establishes a real-time model, which denotes reaction plates, reagent plates and sample plates separately. It displays some detailed information for locations where mouse cursor stops during the testing.

Here several different color hints.

Reaction plates: the light blue denotes reagent blank; the blue denotes calibration; the yellow one is control sample; the wine one denotes reactant.

Sample plates: the green denotes sample; the orange denotes calibration.

Reagent plates: the light blue means reagent is enough; the yellow means reagent is not enough.

The steps of testing:

- 1, Input samples, control samples and calibration samples.
- 2, Do cuvettes water blank test and save
- 3, Three times for "Wash probe"
- 4, Start to test

Attention

- Steps of testing please see Chapter 6 “The regulation of routine operation”

Functions for other modules:

Allow adding sample : Choose the check box means that it is allowed to add samples during testing. If removed it, the analyzer will stop adding samples and keeping testing former reactant.

▲ Test sort

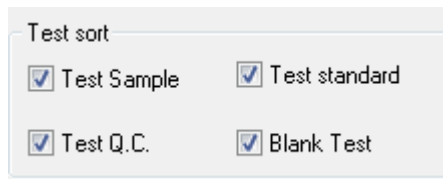

Test sort

<input checked="" type="checkbox"/> Test Sample	<input checked="" type="checkbox"/> Test standard
<input checked="" type="checkbox"/> Test Q.C.	<input checked="" type="checkbox"/> Blank Test

Test sample : If you invert to choose the check box, the system will not test samples.

Test standard : If you invert to choose the check box, the system will not test standard.

Test Q.C. : If you invert to choose the check box, the system will not test Q.C.

Blank Test : Test blank: the system will test all reagents blank.

Start cup for test : Means the system take the cup inputted as the beginner.

: After adding samples, control samples and calibration samples well, click this button to start test.

Attention

- Ensure enough distilled water is (deionized water) in the barrel and the waste liquid barrel is empty before testing
- Check whether the waste liquid tube does not bend and all tubes connected well.
- Ensure reagents; samples; control samples and calibration samples are all right before testing.
- Don't lay reagent, sample; control sample and calibration sample on the table-top of the analyzer. They will damage the analyzer if they are toppled.
- Prohibit using the function, which causes the analyzer to move during the testing. Such as "cuvettes water blank test" and "equipment maintenance".



- Samples, control samples, calibration samples and waste liquid have potential biological risk. Thus, the operator should wear personal protective device and comply with safety regulations of the laboratory.

 **Warning**

- Obligations for the operator to drain and dispose overdue reagents, waste liquid, wasted samples by regulations of states and local governments.

5.5.2.1.2 Blank test

In order to eliminate discrepancy among cuvettes, the system should test each cuvette.

Steps are as follows: firstly, test blank absorbencies and voltages for each cuvette under different wavelengths and then deduct the blank absorbencies for next biochemistry testing calculations.

For getting more accurate testing results, cuvettes water blank test must be done before testing new samples every day.

Click main menu "Test/Blank test" or task navigation "Device run/ Blank test. The system will show as the below Figure 5-7.

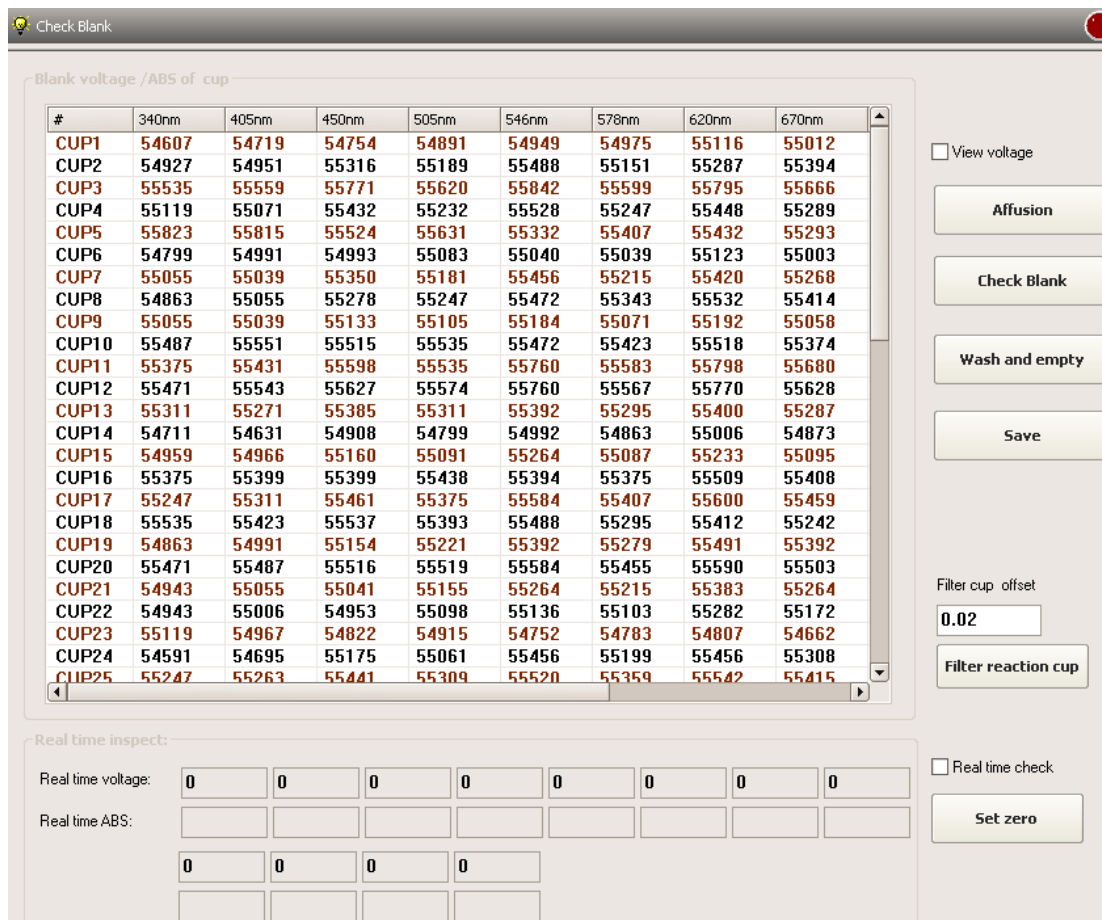

Figure 5-7

As the above figure shows:

The left column displays the numbers of cuvettes and the top column displays the filters.

Besides, it also records voltages of all the cuvettes. It is necessary to switch the check box "Show voltage" to display absorbency of each cuvettes. If you want to take the real-time check, please choose "Real-time monitoring."

The normal scope of voltage of cuvettes is 30000~62000. Generally speaking, it can be set from 55000 to 56000 during debugging.

Steps of routine cuvettes water blank test as follows:

- 1, Enter into "Device maintenance," and three times for "Wash pipeline".
- 2, Enter into "Blank test" and click "Affusion" and then click "Blank test" three times. The testing results should be stored every time.
- 3, Set the discrepancy of the cup filtration as 0.025 firstly and then click "Filter cuvettes". If

the cuvette water blank absorbency is not more than 0.002, it means the analyzer is normal. Or not, retest after washing. At last, click “wash and empty”.

4, Blank test can be set combination action to finish by one button.



- ❖ Take blank test three times and notice the absorbency of cuvettes is not more than 0.002.
- ❖ You must pump after the cuvettes water blank test or else it may bring some troubles.
- ❖ Blank test is used to filter the reaction cups to get more accurate testing results.
- ❖ If absorbency of cuvettes exceeds 0.025, rewash and retest them or change them.

5.5.2.1.3 Device maintenance

In order to ensure the analyzer runs well, routine maintenance is a part of routine operations. It is necessary to take maintenances to the analyzer before or after test.

Click “Device run/Device maintenance”. The system will show as the Figure 5-8 shown.

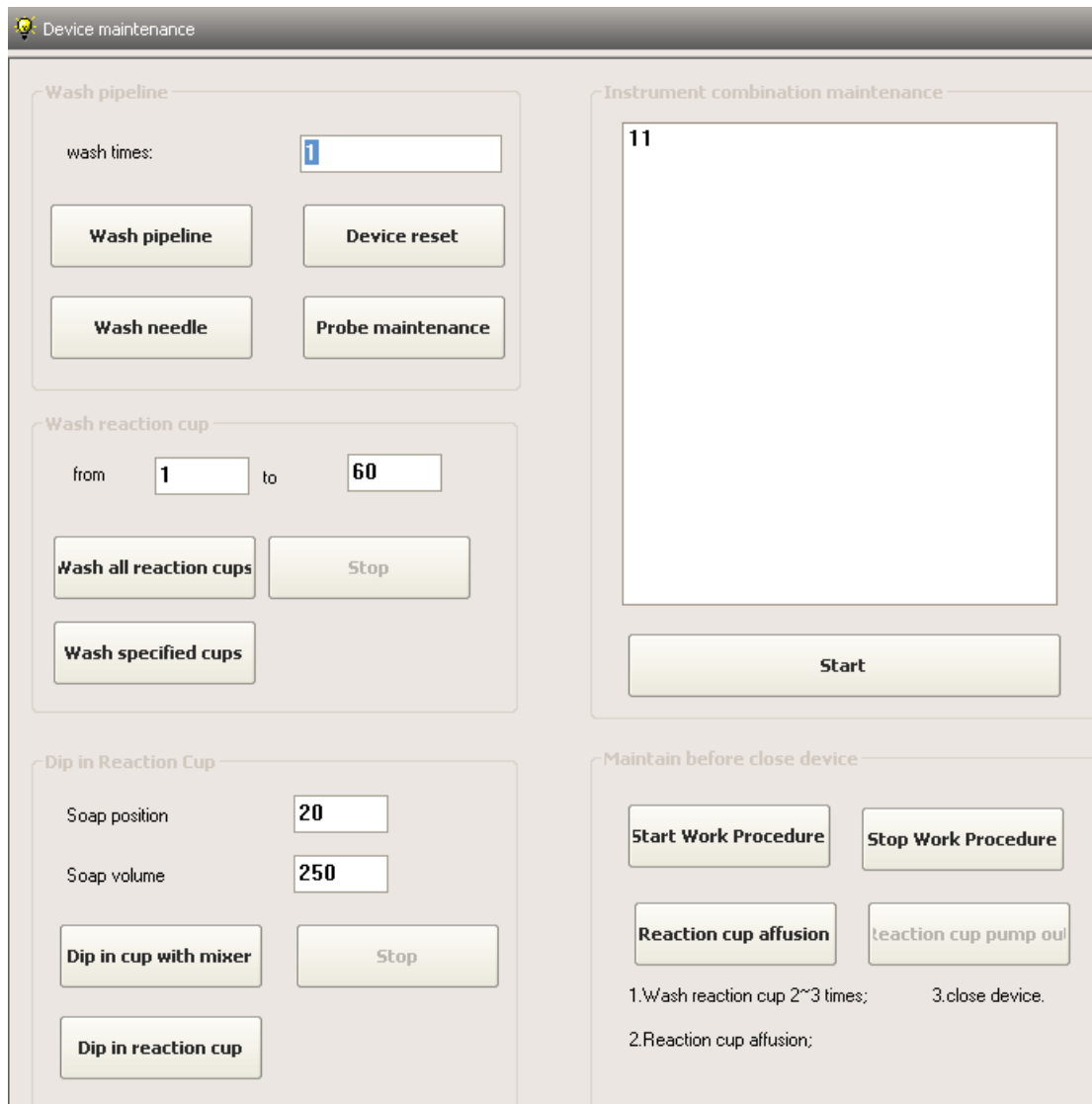
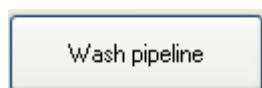
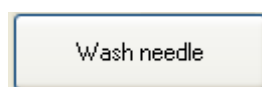

Figure 5-8

▲ Wash pipeline



: It is used for clearing pipelines and avoiding the reactant from staying in the pipelines and eliminating bubbles in the pipelines .While the analyzer is turned on or has been waiting for a long time, please use this function to wash pipelines four times



: It is necessary to use this function to wash probes three times for eliminating bubbles in the pipelines. Or else, it will bring some discrepancies for testing results.

Probe maintenance

: Fill the position 1 of reagent panels and the position 1 of sample reagent with acid detergent separately firstly and input the number of washing as three times and then click "Probe maintenance." Besides, they need to be washed with alkaline detergent by the same procedure.

Device reset

: The analyzer will accomplish replacement, ensure all arms at zero position when click this button

▲ Wash cuvettes

Wash all cuvettes

: Wash all cuvettes to avoid the reaction liquid keeping away from them.

Wash specified cuvettes

: Wash the specified cuvettes.

▲ Soak cuvettes

Soap position

: soap position, can choose 1 to 36 reagent position.

Soap volume

: soap volume, can choose 1ul to500ul.

Soak cup with mixer

: Add detergent into cuvettes and mix.

Soak cuvette

: Add detergent into cuvettes.

▲ Equipment combination maintenance

Select names of movement combination and click "start" to accomplish. The user can set the sorts of maintenance procedures and blank test freely.

During the proceeding of combination maintenance, it will dap out a dialog box, which shows current action condition. The system will show the condition of blank test of every cup automatically after detecting the blank cup. As Figure 5-9 shown, blue hint: it means the filtration of blank cup is above 0.025, if it appears more than 10% blue hint, it must be rewashed and redetected; red hint: means it is above 30000-62000 which is normal detecting voltage range, below 30000, it needs to be changed reaction cups; if above 620000, detecting voltage needs to be adjusted. -1.0000: means not install filter or

mistake.

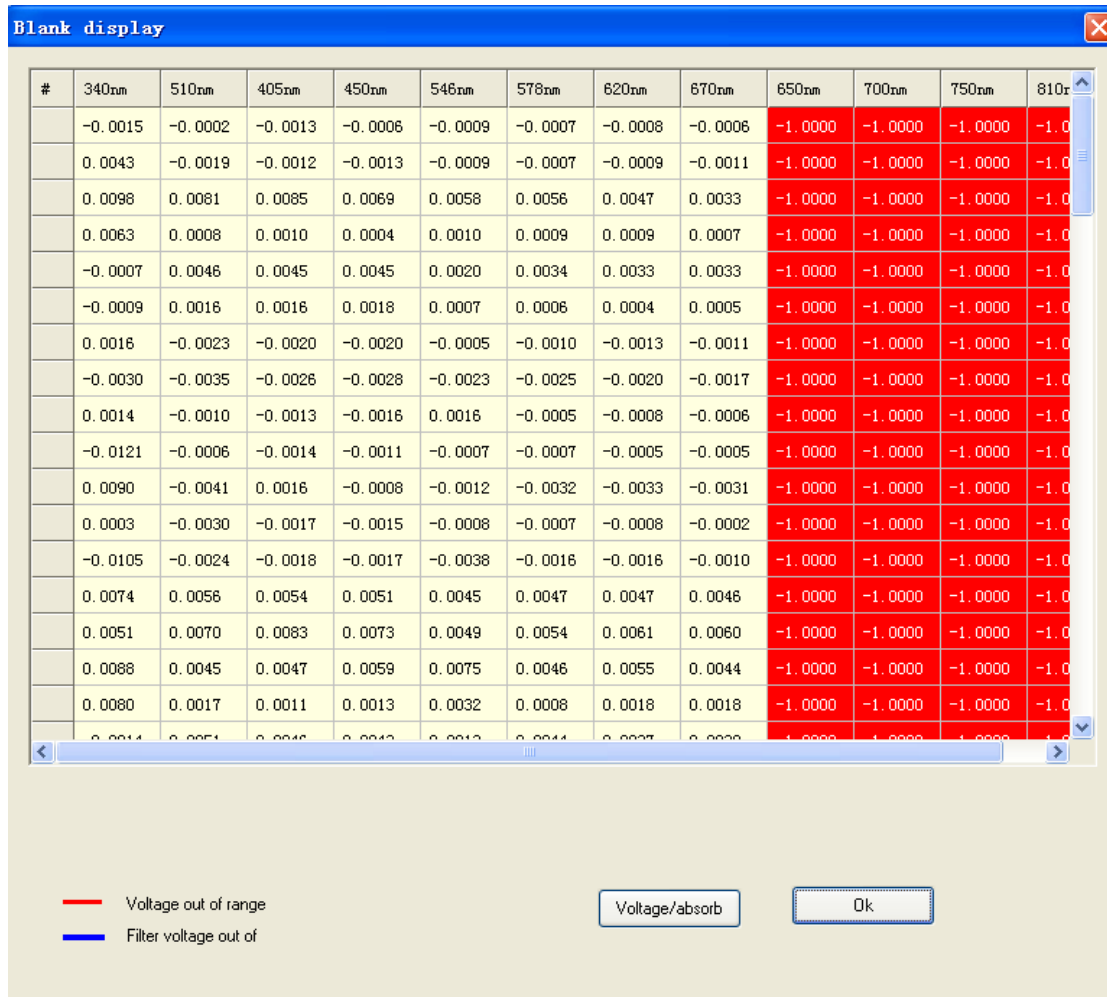

Figure 5-9

Attention

- In device maintenance interface, on the left is the movement of the maintenance, on the right, it can set those movements together as users' requirements. It is convenient for users to complete the equipment maintenance and blank test.

▲ Start/stop work maintenance

- : execute maintenance of start work
- : execute maintenance of stop work
- : affuse in cuvette.

Reaction cup pump out

: pump water from cuvettes.

5.5.2. Test task

Samples, calibration and control functions can be added freely in test task.

5.5.2.2.1 Add sample

Press “Task\add sample” or “Test task\add sample” in navigation bar, it will be showed as Figure 5-10:

Sample ID

Patient ID: -> Name: -> Sex: Age:

Barcode input

Bar code scan Cup correction Single scan

Manual scanning Scanning... Don't change interface

Other task

Run1 Run2

Sample information

Sample ID: Sample Style:

Dilution ratio: Cup position: Container:

Send Date: Number of items:

Preset Batch: Emergency

ALTS FIERL TRIG
 UREAS MGL UA
 ALT LDL HDL
 urea TBIL MG
 ALP TBILL GLU
 TP DBILL CHO
 ALB AST CA
 CRE UREE
 DBIL GGT

Batch add

Batch add
 Use same cup

Enable Add Sample

Uncheck Use

Input sample task:
single Add:1.Add Sample; 2.Select item;3.OK
Batch add:1.Add sample;2.Select item;3.Select Batch;4.OK.

Figure 5-10

▲ Patient ID: ->

After adding samples, the patient information can be input here or in sample results.

▲ Name: -> Sex: Age:

After adding the task, click the sample number, then click "single scan", the instrument only scan the sample.

Cup correction

After scanning the test tubes, if there was a shift or repack, can use this button to scan and determine a new samples.

Manual scanning

If the instrument installs the external scanners, can click here, holding the scan barcodes button.

▲ Other task

Run1

Run2

: Can use some executable files, such as printing, many-rules quality-control diagram, can copy the file that need to run to work directory.

The file name: run1. exe run2. exe.

▲ Sample information

Sample information

Sample ID: 201108290033 Sample Style

Dilution ratio: 1 Cup position: 2 Container: Cup

Send Date Number of items: 1

Preset Batch Emergency Clear

BCS ALB1
ALT CK
alt1 GLU
UREA1 tg
Urea UA
ALP FE
TP qq
ALB
CREA

Figure 5-13

Sample ID: The system will automatically obtain ID number after adding samples.

Sample Style: Choose the type of sample, and it also can be preset such as serum, plasma, urine, and myelencephalon.

Dilution ratio: Manual dilution, as general is 1, if samples use the manual dilutedness, it

only needs to input the actual dilution ratio. For automatic dilution, the item parameters should be set up in multiples.

Container : Input sending date, which is defaulted to be current date in the computer system.

Send Date : Input the send date, which is defaulted to be the current date in the computer system.

Number of items : Item number need not to be set up.

Preset Batch : If the user has set up combination item, which can be added directly, e.g.: liver function, kidney function ect.

Emergency : If choose it means the sample is emergent to have preferential test.

Clear : Cancel all the selected test items.

Item column: Column lists all items which have been set up. Users can select corresponding checkbox directly.

▲ Batch add

Batch add It means add more than one item with the same test sample at the same time. First, select its checkbox, and then set up sample numbers.

Use same cup For adding batch samples, if you use the same cup to test many times, can select the button, if not, cup numbers of batch add sample and sample ID will automatically accumulate based on 1.

Functions of other modules as follows:

Enable Add Sample Select the checkbox to add samples and emergency treatment at any time, do not need stopping. If you do not choose the function, the

equipment will not add sample.

Add sample

Click this button to add samples.

Edit sample

Through this function, added sample information can be edited.

Steps for editing samples:

1. Selected sample ID on the left list.
2. Click "Edit sample"
3. Edit sample information.
4. Click "OK"

Delete

Delete samples which have been added, click (Ctrl), or select (Shift) sample ID needed to be removed from the left list, and then click "Delete".

Ok

Confirm added samples or emergency samples, added sample ID will display on the left list.

Test

Click this button to enter test interface.

Steps for inputting samples may following hints :

Input sample task:
Single add:1.Add sample; 2.Select item;3.OK
Batch add:1.Add sample;2.Select item;3.Select batch;4.Ok.

Uncheck

Indicates current date, sample ID is unchecked in the sample ID list.

Uncheck

Indicates current date, sample ID is unchecked in the sample ID list.

If retest checked samples,, first change Uncheck into Uncheck , then select sample ID, then click "Edit sample", ALP means items have been tested. If we need retesting,

click it twice, with display ALP .click "OK" button after editing. The equipment will immediately retested ALP when it is in the detection state; but if the equipment is stopped, which needs to rerun the test.

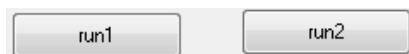

: The column indicates some executive documents can be used, such as calculator, . Also it can be used for copying some documents into working directory for reference.



Electrolytes: For the analyzer with ISE, it can be input electrolytes items

Attention

- Sample message e.g. "sample style, containers, preset batch" in the drop-down list is set in "Item \ other setup...."
- "Container" must choose the type with the same type of the actual use; otherwise probes will be easily damaged.
- Patient information and registration information can not be setup when add new samples, after finishing test for samples, they can be set up in the menu of "Result \ sample result" or "Browse result \ sample result",.
- If batch is added, samples cup numbers of batch add and sample ID will automatically increase based on 1.
- If the bar code scanner is connected, barcodes on samples tube can be scanned directly with it.

5.5.2.2.2 Add standard

During using the analyzer, maybe have a certain degree of deviation absorbance because of the preservation of reagents and cuvettes prolonged use. The deviation may lead to wrong or unreliable test results. Calibration operation is to calibrate equipment and improve accuracy of results. Of course , first time used, you need calibrate

Click "Task \ Add standard" or "Test task \ Add standard" in the navigation, as Figure 5-14 shown

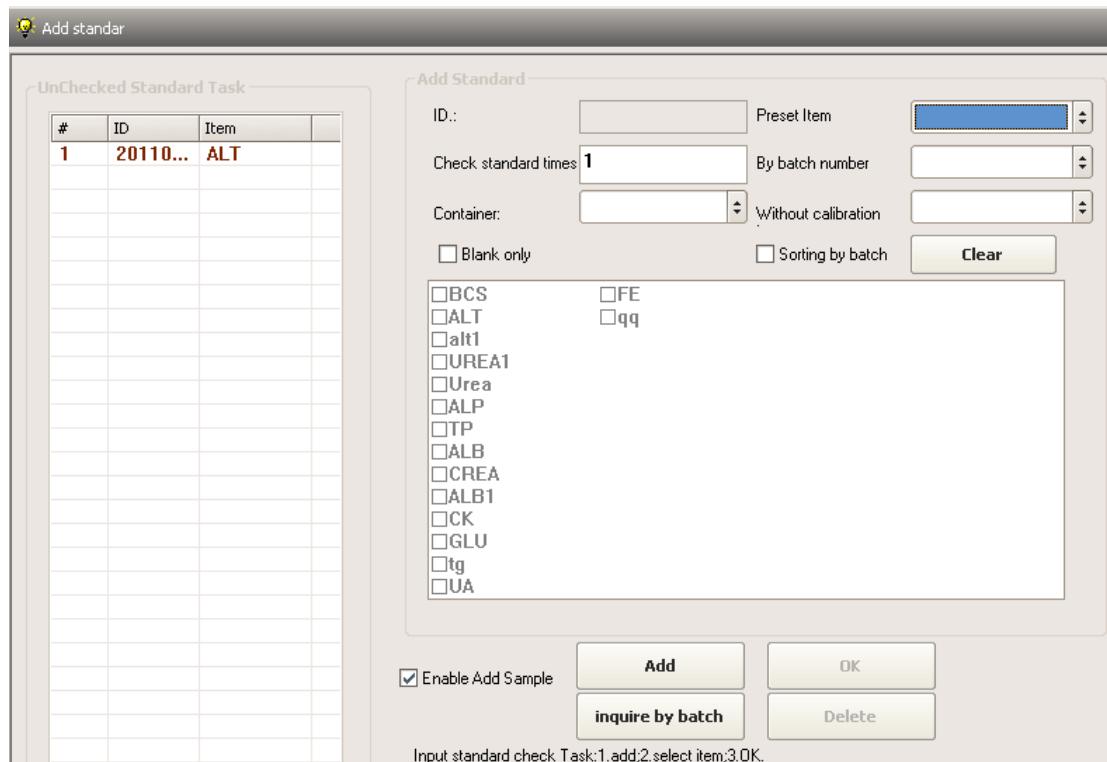

Figure 5-14

ID: Click "Add" button, the system will automatically obtain the calibration ID number.

Preset item The preset item can be chosen.

Check standard times Input calibration numbers. Suggestion that inputs 2 times maximum.

By batch number When calibration, can input or choose the existing standard batch number.

Blank only If only want to test blank, select checkbox in front of Blank only

Without calibration The projects are without calibration for a week, and they will be listed in the table. When calibration, selecting the project of the table, it will automatically remove.

Sorting by batch By clicking on "sorting by batch" button, then choose the batch number, then click this button to change state, can show all projects of the batch number.

Container: Select types of containers

Enable Add Sample Select the box before adding calibration and it can be input at any time.

Steps are as follows:

1. Click "Add"
2. Select calibration, or choose preset item.
3. Select types of containers
4. Input numbers of calibration, if only test blank, select the checkbox in front of "Blank only."
5. Click "OK"

If you want to delete added calibration, please select calibration on the left of the list of "Unchecked standard task," then click "Delete" button.

Add the calibration process, can add the project that need to add to the same batch number, then choose corresponding batch number to add directly, and let the hospital operator convenient.

The calibration to batch number for added, Steps are as follows:

1. Add test project that need to add to the same batch number, the specific location in "calibration adding product batch view" of the adding calibration.
2. Input the batch number, then ordinally choose project names, then click the "add" button, you can set the batch number of the corresponding project, as shown in figure 5-15.
3. In the adding calibration interface, choose related batch number, then choose "by batch number" option, then choose the corresponding project in the batch number, as shown in figure 5-16.

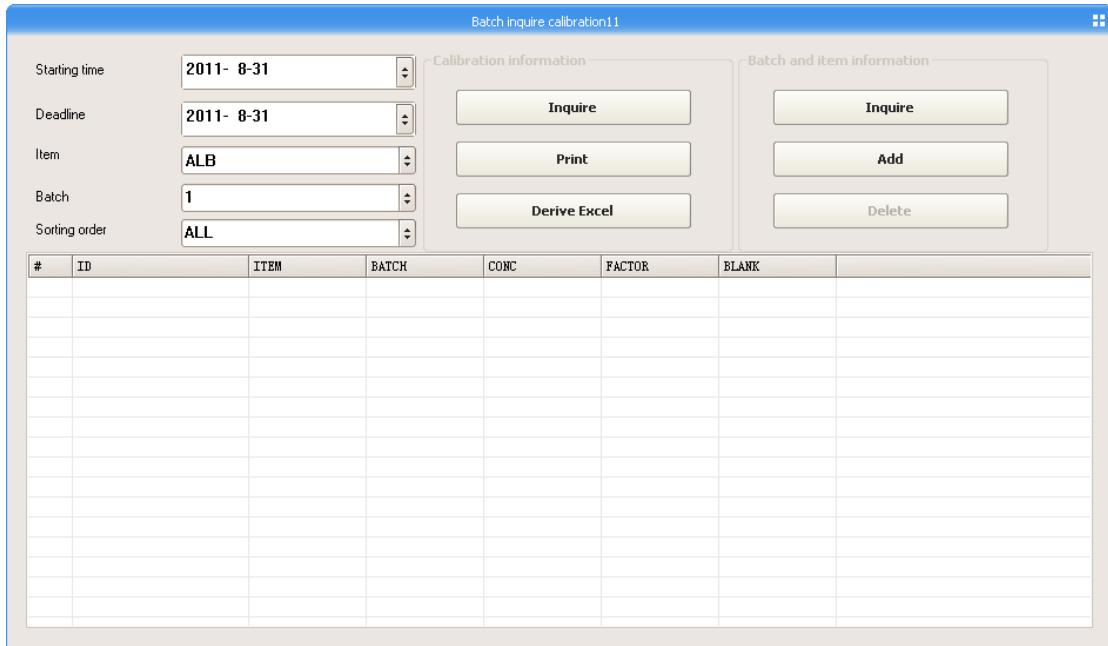

Figure 5-15

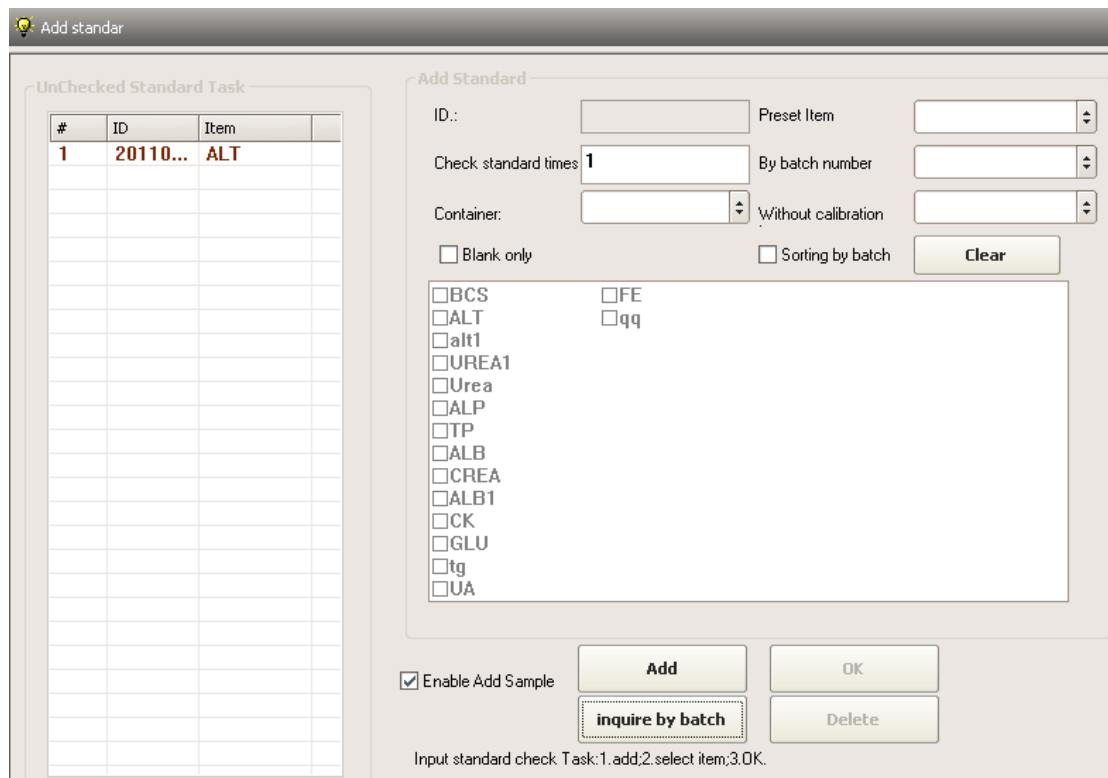

Figure 5-16

In "Inquire by batch" of the add calibration interface , can use project or batch number way to view all of the calibration batch results information, and can be sent the results to excel form, and at the same time can print, can also add and view the new calibration batch number, as shown in figure 5-17.

Batch inquire calibration11

Starting time: 2011- 8- 1
 Deadline: 2011- 8-30
 Item: BCS
 Batch: 1
 Sorting order: ALL

Calibration information: Inquire, Print, Derive Excel

Batch and item information: Inquire, Add, Delete

#	ID	ITEM	BATCH	CONC	FACTOR	BLANK
10	20110812160816	ALB		30.0000	17.1738	0.1991
11	20110812102236	ALB		30.0000	23.1678	0.2036
12	20110826085007	ALB		30.0000	13.2976	0.2272
13	20110817140008	ALB		30.0000	22.5471	0.2009
14	20110817105239	ALB		30.0000	22.2494	0.2062
15	20110829143546	ALB		30.0000	16.1577	0.2371
16	20110825095856	ALB		30.0000	19.7141	0.2014
17	20110824171032	ALB		30.0000	20.2497	0.2019
18	20110819155829	ALB		30.0000	19.8992	0.2009
19	20110827135000	ALB		30.0000	14.0574	0.2265
20	20110818144210	ALB		30.0000	19.7096	0.2001
21	20110812092551	ALB		30.0000	23.7906	0.2045
22	20110816151313	ALB		30.0000	19.4326	0.2091
23	20110817161255	ALB		30.0000	18.8147	0.1989
24	20110827114545	ALB		30.0000	13.5980	0.2286
25	20110818154853	ALB		30.0000	19.4062	0.2003
26	20110816140009	ALB		30.0000	0.0000	0.2127
27	20110818084858	ALB		30.0000	20.7555	0.2036

Figure 5-17

Attention

- Add calibration, strictly in accordance with the interface hint "enter calibration task steps."
- Preset items and containers dropdown list can be set up in the menu "Item \ other setup."
- When test routine item, without being calibration item, we suggest choose "Blank only", the absorbance change of reagent can be deducted effectively.

5.5.2.2.3 Add Q.C.

During operating the analyzer, in order to ensure that test results meet requirements of clinical testing, the operator runs Q.C. every day to ensure that results of sample analysis are reliable and accurate.

Click "Task \ Add Q.C." or "Test task \ Add Q.C." in the navigation bar, as shown Figure 5-18:

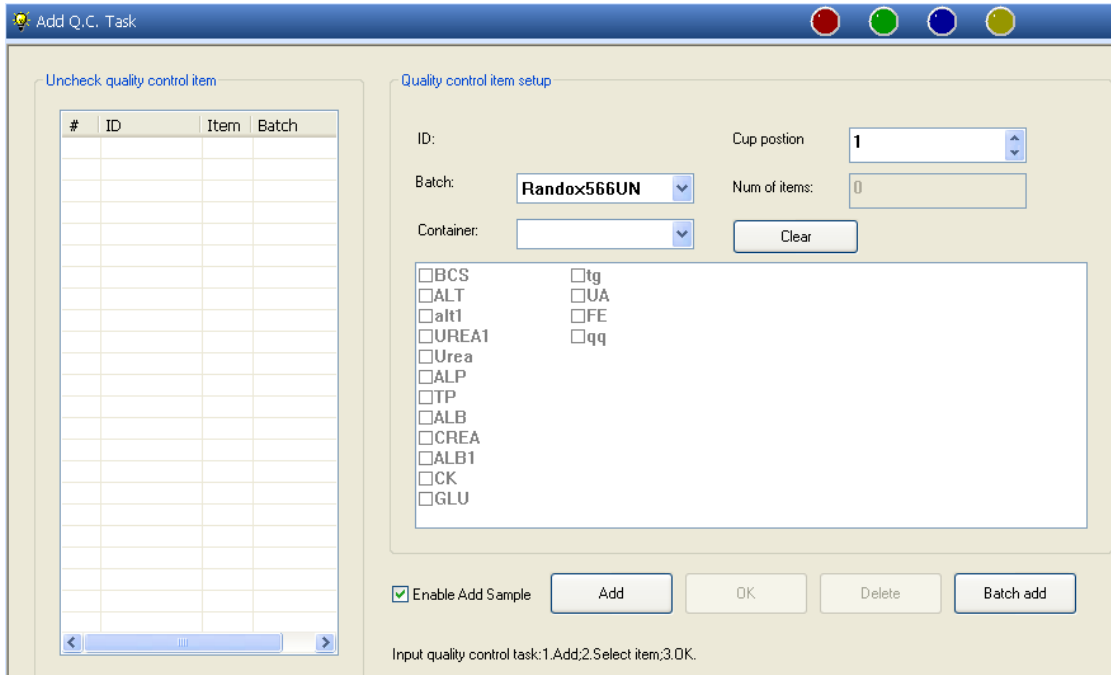

Figure 5-18

ID: Click "Add" button, the system will automatically obtain the ID number of control.

Batch: Choose batches of control.

Cup position Input the location of control in sample plate.

Container: Select types of containers

Num of items: Item numbers need not to be set up, only for statistics function.

Enable Add Sample Select the checkbox before adding control and it can be input at any time.

Steps are as follows:

1. Click "add."
2. Select control batches.
3. Select control items in the list of control item
4. Select types of containers.
5. Input the location of Q.C in the samples plate.
6. Click "OK".

If you want to delete added control first select control on the left side of the "Unchecked control item" list, then click "Delete" button.



In the add Q.C.interface, can inquire the quality information by batch, can be sent the results to excel, and at the same time also can print, and can set new information, that is, the quality target value and SD range, as shown in figure 5-19.

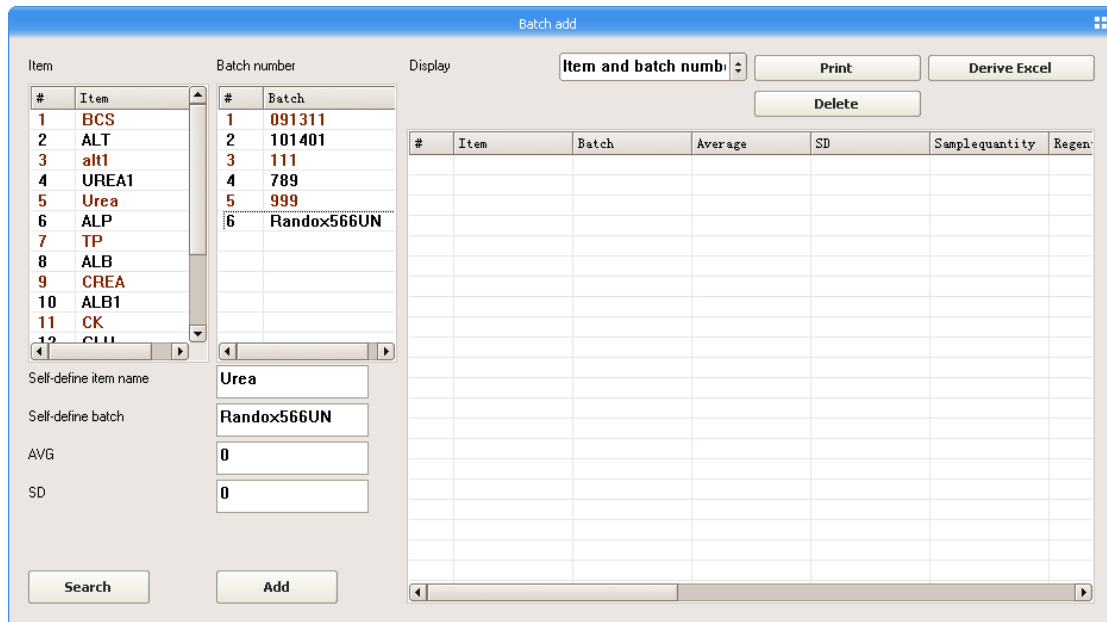

Figure 5-19

Attention

- When control is added, strictly follow the hint that "steps of inputting quality control".
- Control must be set up in advance, and then the control can be set up according to different preset batch. Details see 5.6.2 Control Item Setup.
- Preset items and containers in the drop-down list can be set in "Item \ other setup".

5.5.2.3 Browse results

Provides browse result functions for samples, calibration, and control.

5.5.2.3.1 Sample results

Click "Result \ sample result" in the main menu or "Browse result \ sample result" in the navigation task, as shown in Figure 5-20

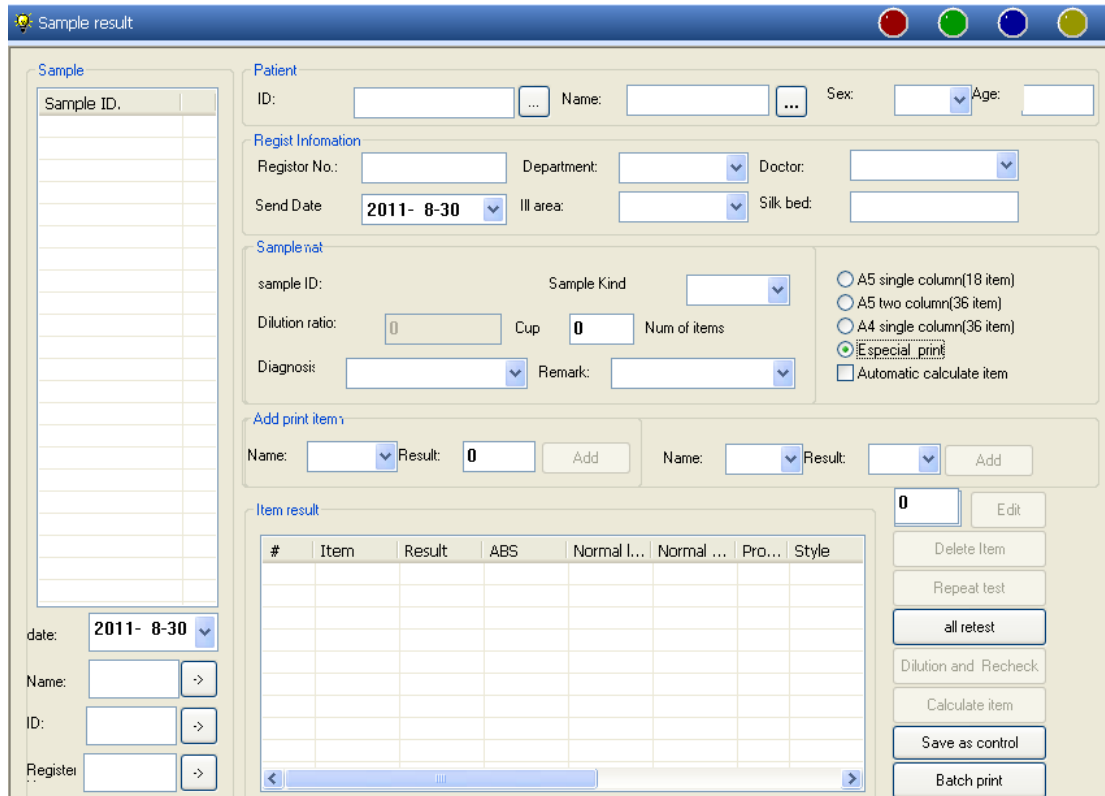
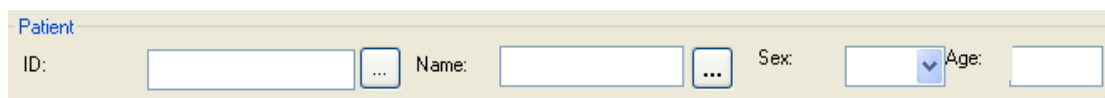

Figure 5-20

After selecting sample ID from sample list, test results of samples will display in the list. At this point can enter the appropriate information and carry on the corresponding operation.

▲ The patient



Enter patients information and ID simultaneously, they will be automatically displayed. If ID had been input when sample is added, patient information will display here automatically.

▲ Register information

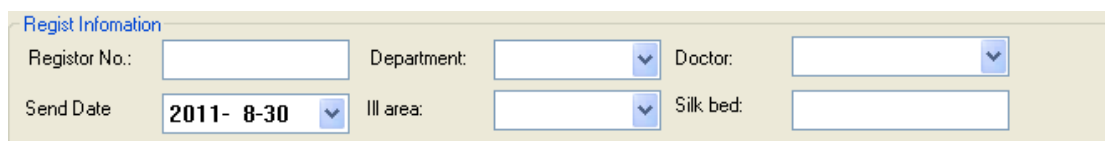

Please enter registration information, if it has been entered when add samples, it will display automatically here, however also need to choose sending date for current date is defaulted by system.

▲ Samples

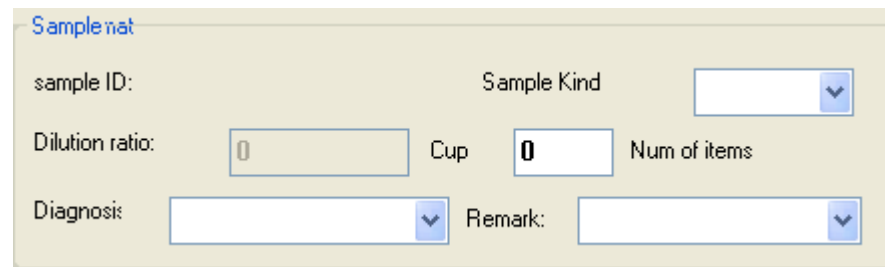

The screenshot shows a form titled "Sample nat" with the following fields:

- sample ID: (text input)
- Sample Kind: (dropdown menu)
- Dilution ratio: (text input with value 0)
- Cup: (text input with value 0)
- Num of items: (text input)
- Diagnosis: (dropdown menu)
- Remark: (dropdown menu)

sample ID: : Do not enter sample number here, after adding samples, the system will automatically obtain a sample ID number.

Sample Kind : Choose type of samples.

Dilution ratio: : Usually the ratio is which need not diluting; reversely Input actual dilution ratio, and test results will be automatically multiplied by the dilution ratio.

Cup : Enter sample cup

Num of items : Item numbers do not need to be set up, only play a supplementary role in the statistics.

Diagnosis : Select diagnosis contents in the drop-down list.

Remark: : Select remark contents in the drop-down list.

Attention

- Contents in the drop-down list of sample kind, diagnosis and remark are setup and extended in the "Item \ other setup \ list setup".
- Contents of diagnosis and remark can be input directly, but can not exceed 50 characters.

▲ Add input items

Add print item

Name: Result:

Click Name drop-down list to select necessary print item, then input the result in the result box, click "Add" in the end, additive print item result will be shown in the box.

Attention

- Add input items and add print items in order to input test results of other biochemistry items or instruments on the result list for saving and printing.
- "Item \ Print item setup" should be completed before adding print items.

Other buttons function as follows:

Test results can be amended, first check samples ID, meanwhile select items in the results list, and then results will appear in the "Edit" box, Re-enter results and click "Edit" button.

Select items in the result list, Click this button to delete the test results.

First select items, then click this button to retest samples. If the equipment is running, it will be rechecked immediately; or not, needs to start testing.

First select items, then click this button to retest samples. If the equipment is running, it will be rechecked immediately; or not, needs to start testing.

Click sample ID number, then click the button, item will automatically be calculated and shown.

Batch print

Select single or multiple samples on the left side of the list, and then click "Print" to print report.

Dilution and recheck

First select items then click this button to recheck samples after dilution, if the equipment is running, it will be rechecked immediately; or not, needs to start testing

Save as control

The corresponding Q.C. result of the batch number is stored.

▲ Search results

date: 2011- 8-30 ▾
Name: ->
ID: ->
Register: ->

Select Search date, and then enter search contents, click “->” button, if sample information and test results meet research condition will display.



: Click this button, can search the information with the patient before. If you input new ID number, the patient's name and so on, you can click this button to inquire that the sample information exists or not; then click "confirmation", as shown in figure 5-21 shows:

number1	Sample number	Patient number	Name	Age	Sex
1	201108270002	201108270002			

Figure 5-21

▲ Print report format choices

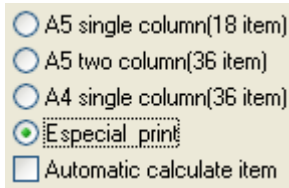

Select appropriate print format what you want every time; the system will set the format as default setting.

▲ Print report format choices:

1) Formats selection

After choosing print formats, should first check setting of printing paper print.ini under working directory, Edit appropriate line numbers and the report can choose 0-3; types, however, the report lines need to be manually modified. The contents of print.ini which under working directory shows are as follows:

[MODE0]	[MODE1]	[MODE2]	[MODE3]
A5 single	A5 two rows	A4 single	especial
PrintStyle=0	PrintStyle=1	PrintStyle=2	PrintStyle=3
autoCal=0	autoCal=0	autoCal=0	autoCal=0
reportLine=18	reportLine=18	reportLine=36	reportLine=11

Print template file: ①samplereport0.rpt , ②samplereport1.rpt ,
③samplereport2.rpt , ④samplereport3.rpt。

2) Template Settings

Follow the method of setting sample report1.rpt: Running software in a

folder  , appear as shown in Figure 5-22

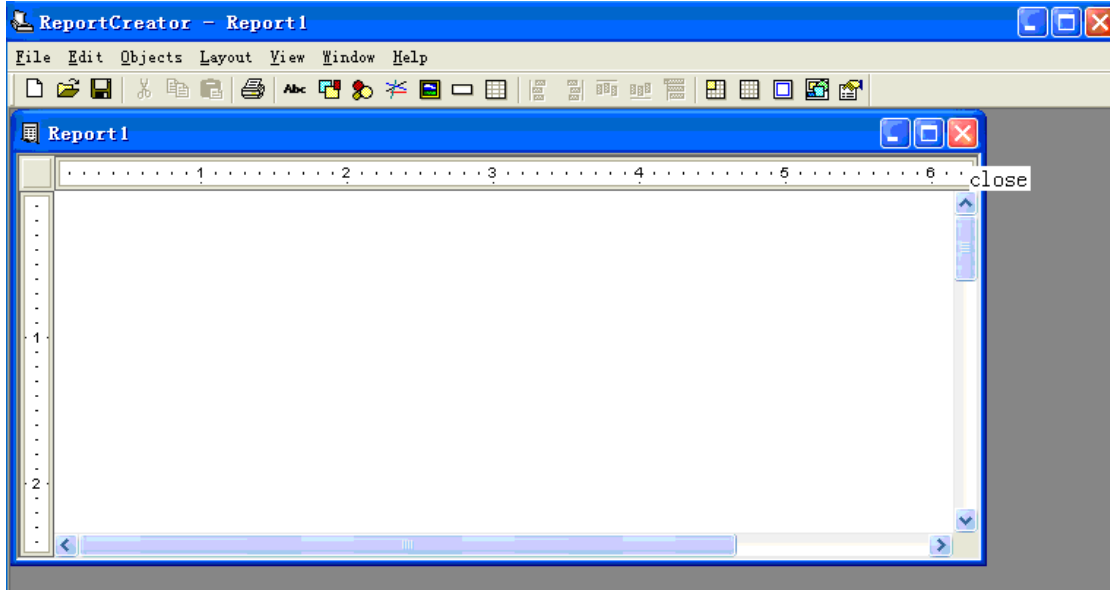



Figure 5-22

Close the empty documents report1, click , Figure 5-23 will be shown:

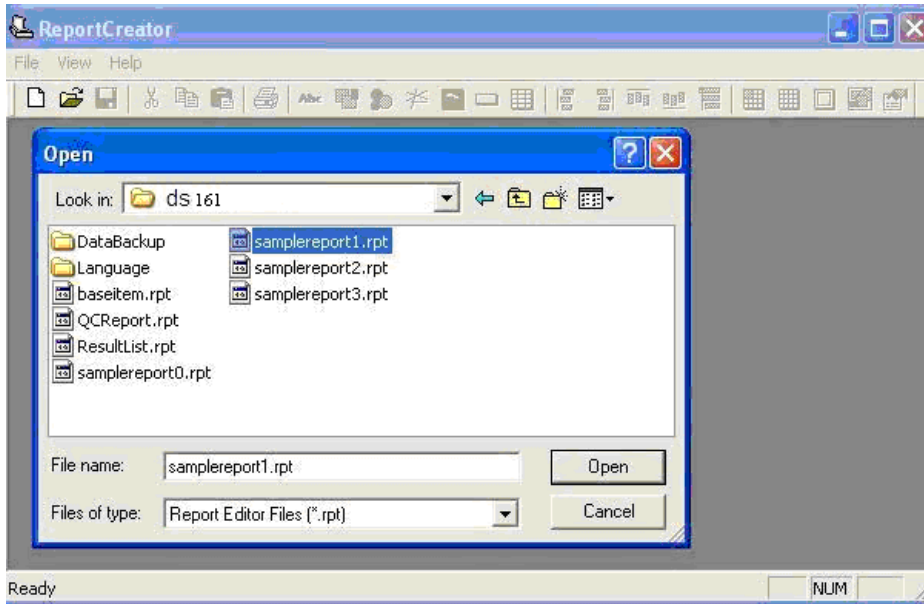

Figure 5-23

Select appropriate working directory and open samples report1.rpt, as shown in Figure 5-24

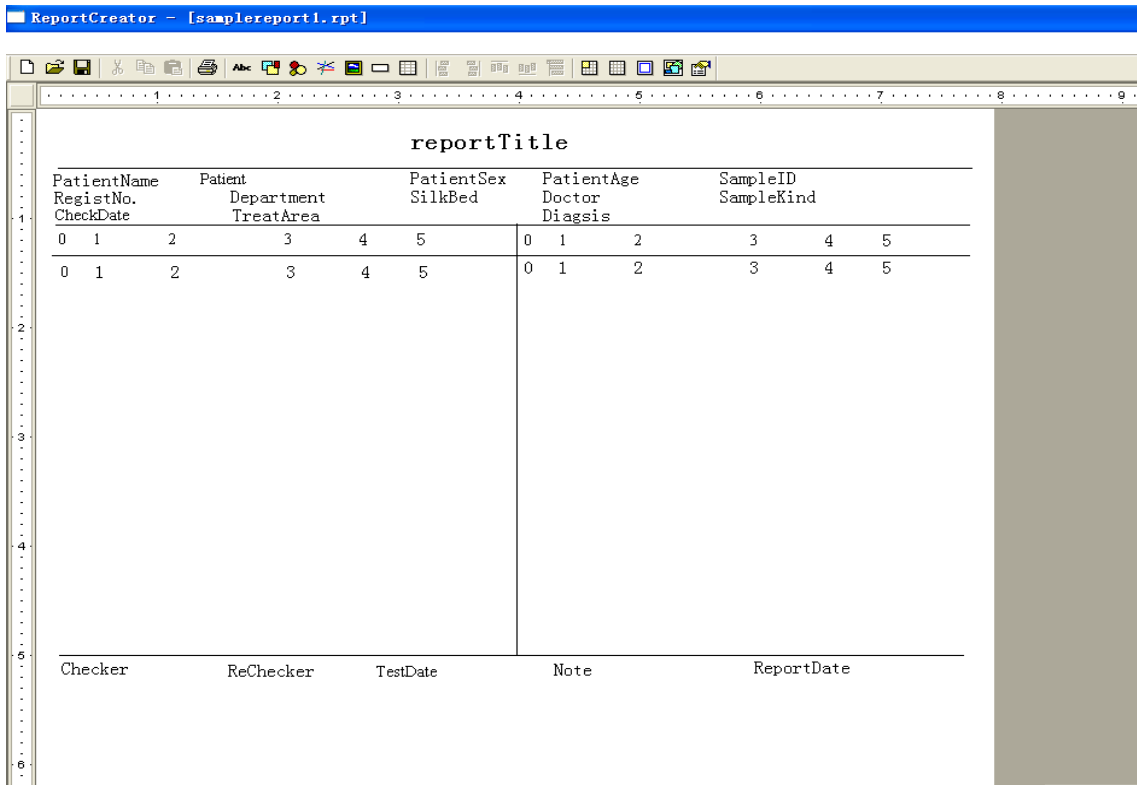

Figure 5-24

Double-click the message box, as shown in below Figure 5-25:

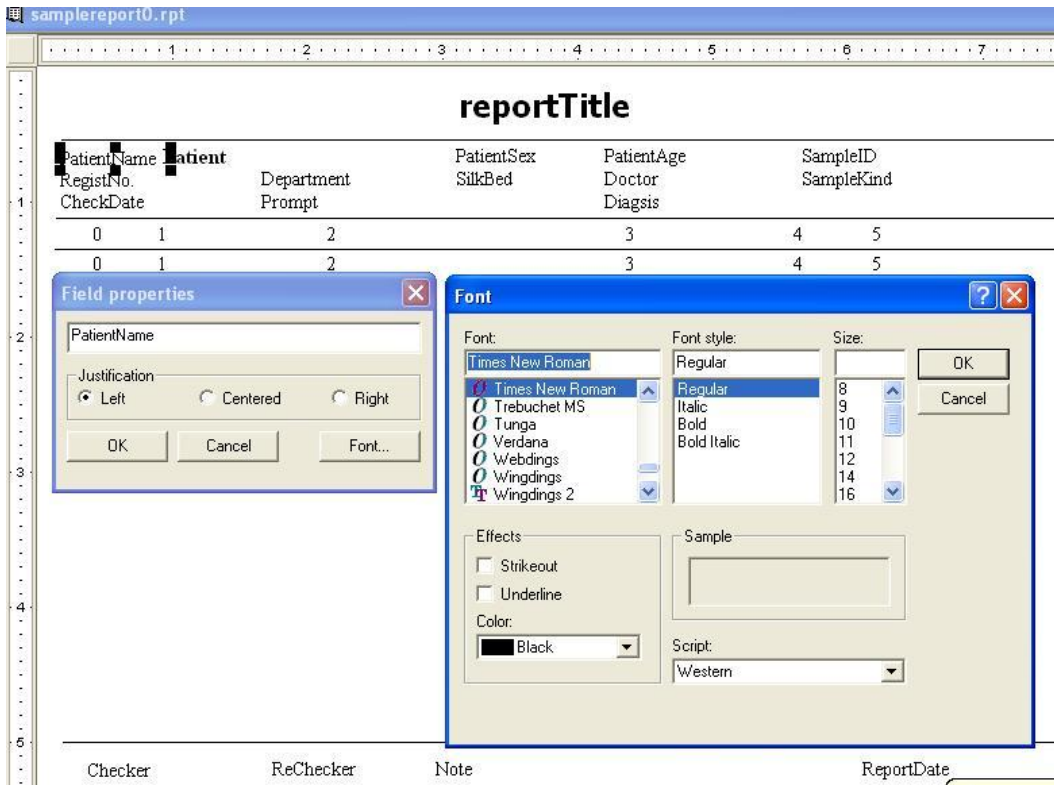

Figure 5-25

Various fields of font size and format can be edited.

Double-click the result box, as shown below Figure 5-26:

:

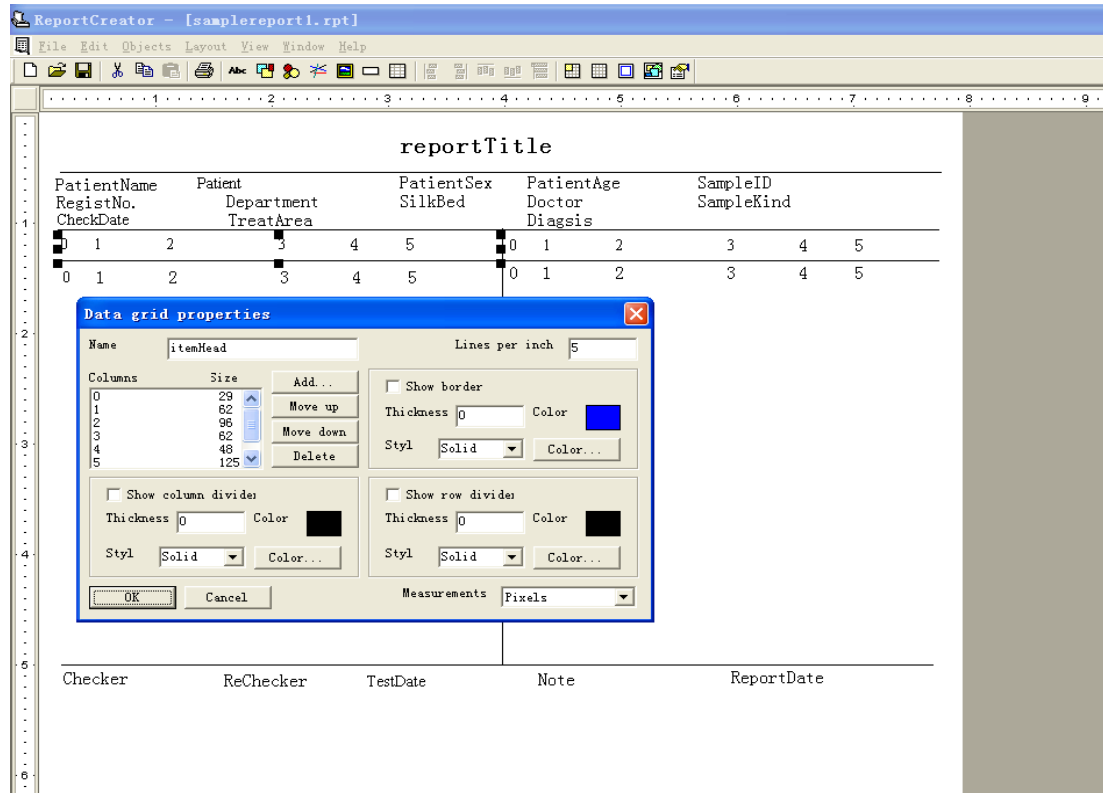

Figure 5-26

Box and column columns can be adjusted.

Attention

- Items base on formulas for “computational item setup”, it needs to be recalculated after results.
- In the print settings, please right-click ungroup to combine and distribute each filed.

3) Special print template setup

This software can support any size of the print format; take the following report as shown in Figure 5-27 for example.

lufthe hospital

Sample ID: 200807020001

register:0001

Name: **tom**

Sex: male

Age: 35

Department: 1

Silk bed:

Sample Kind: serum

Test Date: 2008-7-1

Diagnosis:

remark: high↑ low↓

#	Item	Full name	Result	Unit	Range	#	Item	Full name	Result	Unit	Range
1	GLU1	GLU	4.55	mmol/l	3.45-6.86						
2	ALT	ALT	32	U/L	0-40						
3	AST	AST	37	U/L	0-50						
4	TP	TP	76	g/l	40-83						
5	ALB	ALB	45	g/l	0-53						
6	CRE	CRE	98	g/l	53-108						
7	BUN	BUN	9.5	mg/dl	0-53						

Doctor: jack

test date: 2008-7-1

Report Date: 2008-7-2

Checker: Admin

Review:

Remark: only reference

Figure 5-27

When choose special print, generally use probe print mode, for example, EPSON LQ300K printer, now it needs to be set WINNDOWS printer, to fit the size of each patient report, setup the paper pattern according to the report format.

Take print format width of 25.4 cm height of 11.00 cm for example, WINNOWS settings are as follows:

① Open “Control Panel \ printers and fax machines \ files \ server attributes”, as shown in Figure 5-28 as follows, Create a new form “ds-161” shown in Figure 5-29, e.g.: denominate the metric system, enter: length 25.4cm, height 11.00cm, confirm “save format”.

② Open the printer attributes, as shown in Figure 5-30 as follows, turn the draught paper to “ds161”.

③ Setting in software, after running software, choose “degree” and “sheet size”, choose “ds161”, as shown in Figure 5-31 as follows.

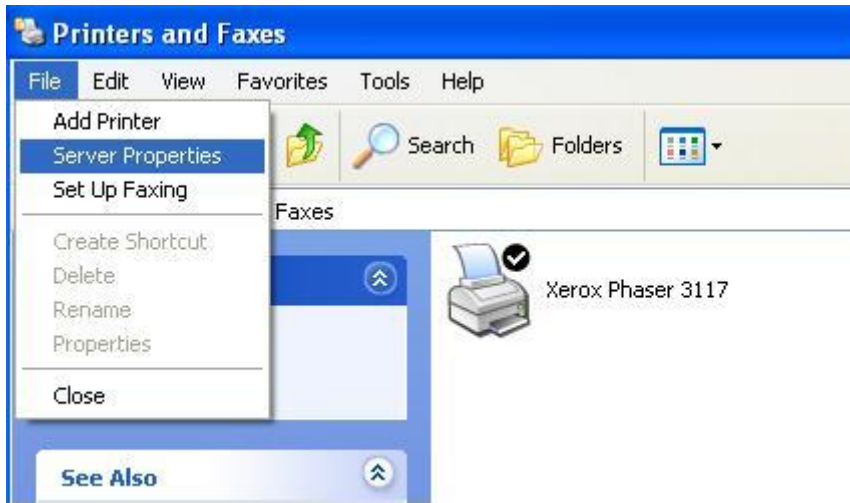

Figure 5-28

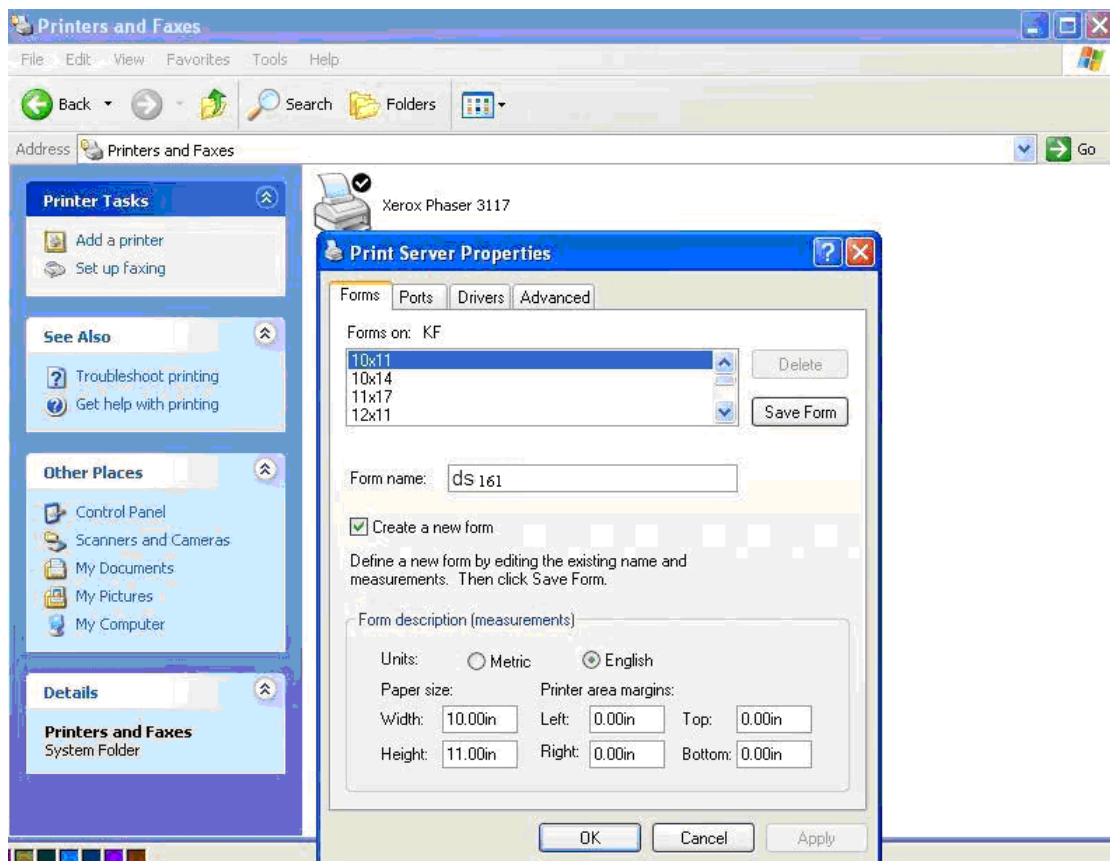

Figure 5-29

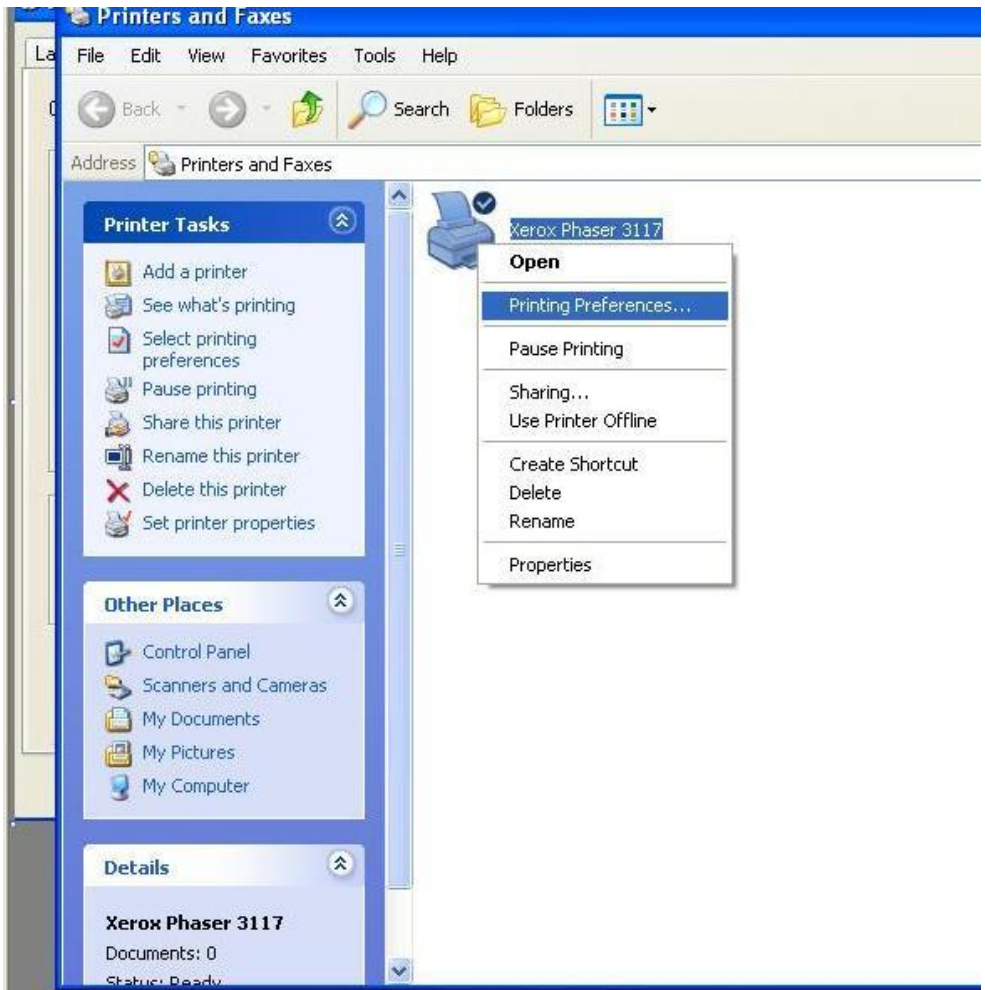

Figure 5-30

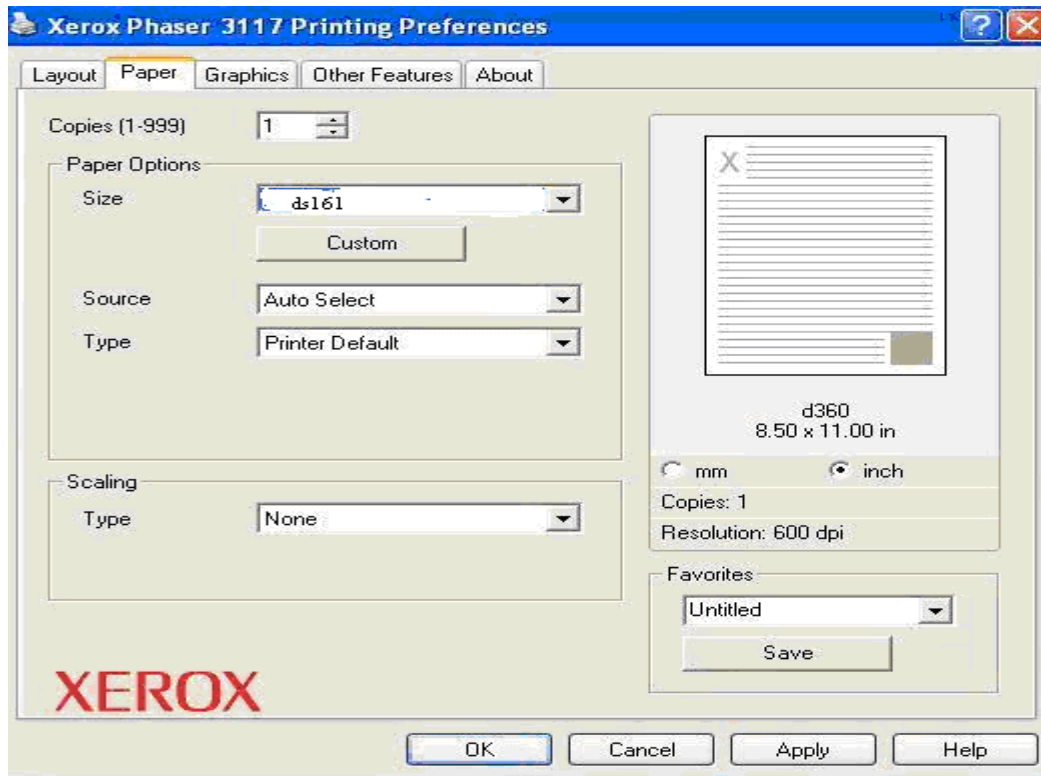

Figure 5-31

④ Setting for printing format document samplereport3.rpt:

Run ReportCreatorEx.exe, close blank file report1, open samplereport3.rpt, it will show as follows Figure 5-32:

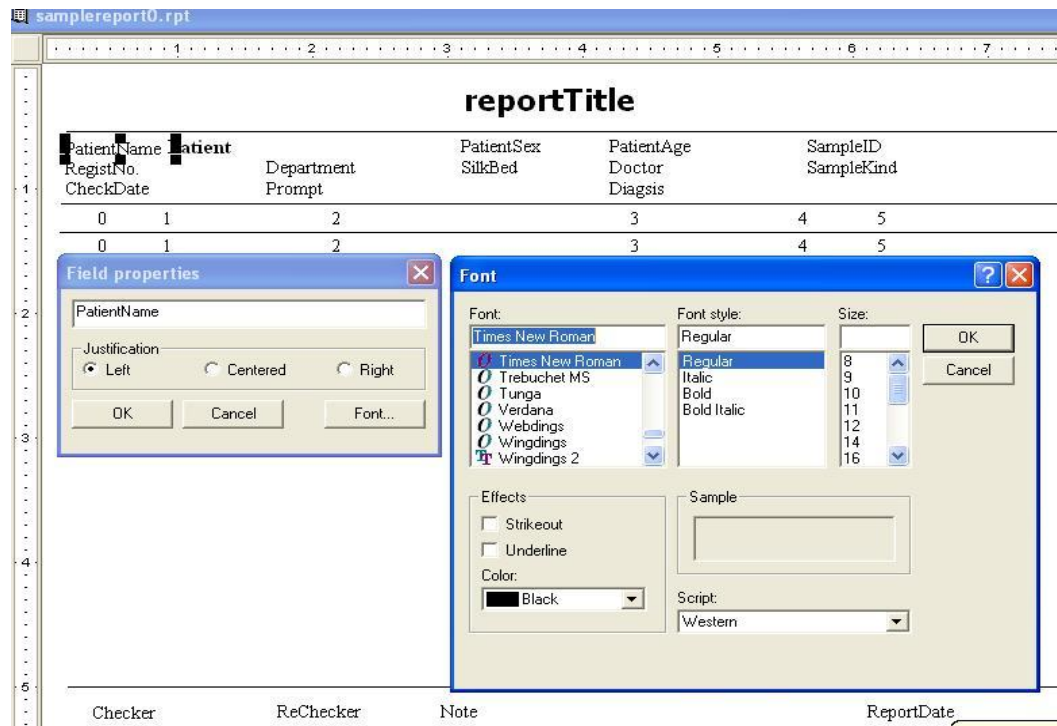

Figure 5-32

Various fields of font size, format can be edited.

Attention

1. When one print format is confirmed, please open working directory and then open print.ini documents, modify printStyle and reportLine.

[MODE]

printStyle=2

autoCal=0

reportLine=18

2. When use paper which has been printed, the unnecessary fields in the model can be deleted.

5.5.2.3.2 Calibration result

Users can find details of the calibration results in this menu.

Click the main menu "Result \ calibration result..." or navigation task "Browse result \ calibration result ". Pop-up system menu, as shown follows Figure 5-33:

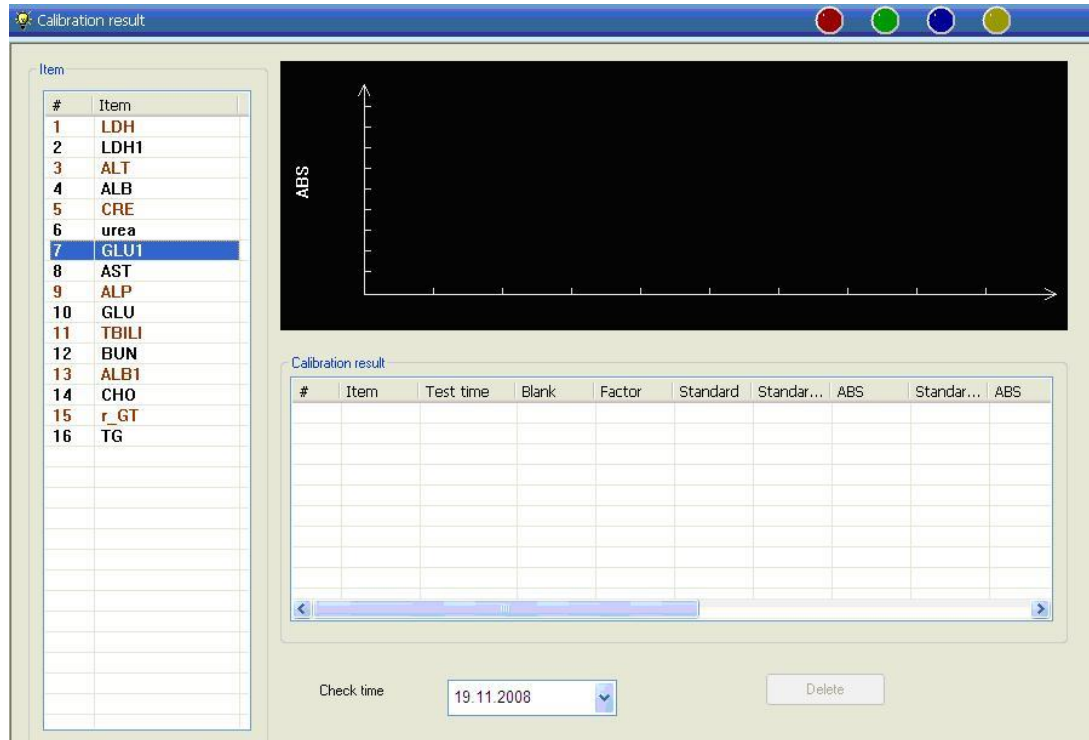

Figure 5-33

Choose the calibration item in the item list, the calibration results with the current date will display in the form of list, and then click it, curves of the calibration will be shown. Choose deleted results in the calibration box, then click "delete".

5.5.2.3.3 Q.C. results

Control analysis refers to unified management of control test results in a certain period, to calculate coefficient of variation and print or output control diagram.

Click "Result\ Q.C. result..." or "Result \ Q.C. result" in the navigation task, Pop-up system menu, as shown in Figure 5-34 as follows:

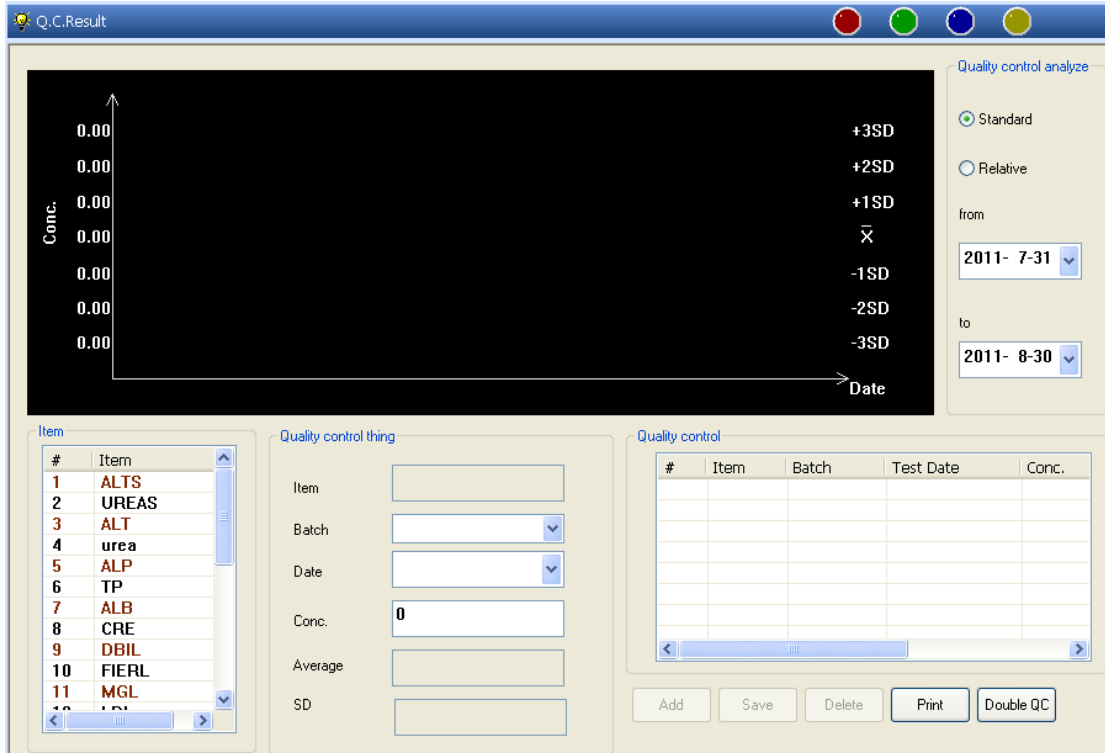

Figure 5-34

Steps are as follows:

1. Select need analysis items.
2. Select the date range of control analysis.
3. All control test results in the selected date range will display in control list. At the same time system calculate coefficient of variation in accordance with results and output control diagram.

In addition, users can also input control results in this menu directly; steps are as follows:

1. Choose the item.
2. Click "Add".
3. Choose the batch number and enter control results.
4. Click the "Save".
5. The added result will be saved in result list and output the control diagram.

Take ALB control result for an example, click biochemical items ALB, and then select control numbers. The results show control, figure control calibrations and values, and other information CV at this time, as shown in Figure 5-35 as follows; it won't show control

Figure 5-36

5.5.2.3.4 Item result

Users can browse real-time results or tested results in accordance with the biochemical item in this menu.

Click "Result \ item result..." or "Browse results \ item result" in the navigation task for the main menu, pop-up system menu, as shown in Figure 5-37 as follows:

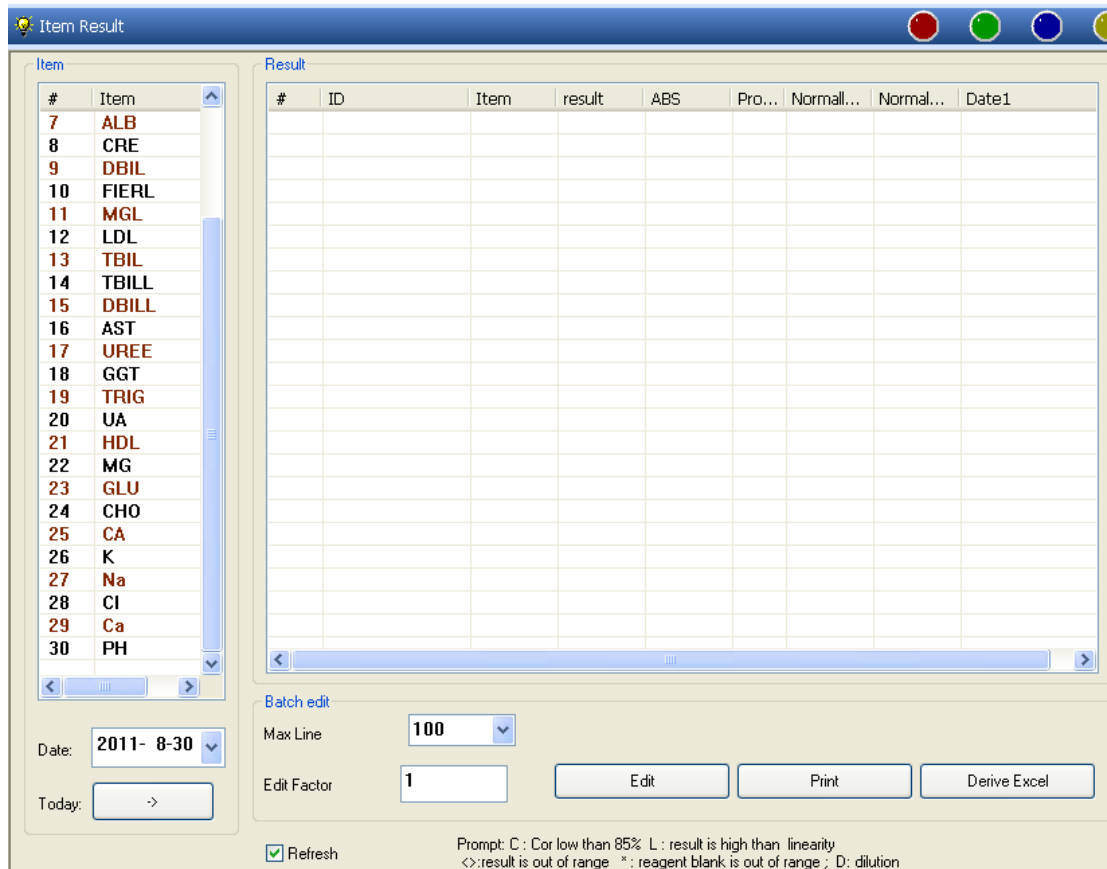

Figure 5-37

Specific methods are as follows:

Choose requisite date, and then select item, results of this item will be displayed in the results list with current date.

❖ Batch Edit

Results to be revised according to offset of quality results

Steps are as follows:

- 1, Inverse "Refresh" checkbox.
- 2, Use "Ctrl" or "Shift" to select requisite item.
- 3, Enter modified factor.
- 4, Click "Edit" button, the corresponding results will be recalculated and saved.

Max Line 

In this option can view results of the biggest rows.

Edit Factor

Input edit factor and click "edit" button to realize the edit of the corresponding testing results.

Print real-time results.

Date: 

Choose requisite date.

Refresh

Refresh the results list

Today:

Display all test results of current system date.

: can send print results to excel file directly; and name and location can be changed.

Tag Help: There are different tag tips in the results, "↑" means results above the normal range, "↓" results below the normal range; "*" means reagents' absorbance exceeds the range set; "L" means results exceeds the scope of linear; "C" means enzymatic test linear curve below 95 %, need to be retested; D means dilution.

Attention

- All of the operation above should cancel the refresh function and switch to other items, and then return to the item.

This menu is also available on the SD and CV value analysis and printing for the same sample test results, check various test results which need analysis, after right-click and

select "CV-SD" analysis or printing, at present it will automatically calculate and display CV and SD values, as shown in Figure 5-38 as follows

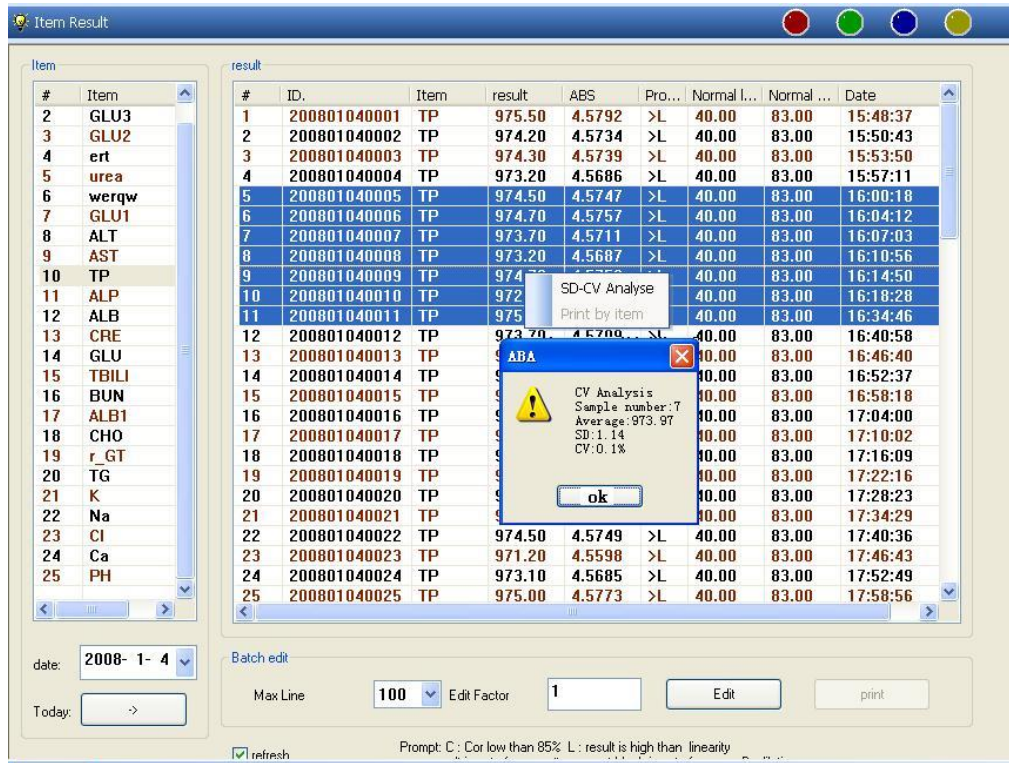

Figure 5-38

5.5.3 Title bar

5.5.4 Monitoring

It can dynamic monitor all the working conditions, as absorbance changes of each cup, the movement of manipulator, the blank status of the original reaction cup, etc. Open real-time monitoring during operating the equipment, and then click single reaction cup, the absorbance changes can be seen during whole process.

5.5.4.1 Reaction trend chart

The reaction curve of test items shown in Figure 5-39 as follows:

 "Monitoring" bar can be displayed and hidden.

Fix the “Monitoring” bar



Figure 5-39

5.5.4.2 Reaction data

Show data for each reaction cup. Vertical column as cuvettes, horizontal column as the reaction cycle, as shown in Figure 5-40 as follows:

The image shows a software window titled 'Monitoring' displaying a data table. The table has 18 columns labeled R1 through R18 and 4 rows labeled 1 through 4. All cells in the table contain the value '0.0000'. Below the table is a navigation bar with tabs: 'Reaction trend chart', 'Reaction data', 'Blank', and 'Action'. The 'Reaction data' tab is selected.

#	R1	R2	R3	R4	R5	R6	R7	R8	R9	R10	R11	R12	R13	R14	R15	R16	R17	R18
1	0.0000	0.0000	0.0000	0.0000	0.0000	0.0000	0.0000	0.0000	0.0000	0.0000	0.0000	0.0000	0.0000	0.0000	0.0000	0.0000	0.0000	0.0000
2	0.0000	0.0000	0.0000	0.0000	0.0000	0.0000	0.0000	0.0000	0.0000	0.0000	0.0000	0.0000	0.0000	0.0000	0.0000	0.0000	0.0000	0.0000
3	0.0000	0.0000	0.0000	0.0000	0.0000	0.0000	0.0000	0.0000	0.0000	0.0000	0.0000	0.0000	0.0000	0.0000	0.0000	0.0000	0.0000	0.0000
4	0.0000	0.0000	0.0000	0.0000	0.0000	0.0000	0.0000	0.0000	0.0000	0.0000	0.0000	0.0000	0.0000	0.0000	0.0000	0.0000	0.0000	0.0000

Figure 5-40

5.5.4.3 Blank

Shown that the blank voltages of cuvettes. Vertical column as a reaction cup, horizontal column as the reaction cycle, as shown in Figure 5-41:

The image shows a software window titled 'Monitoring' displaying a data table. The table has 19 columns labeled R1 through R19 and 4 rows labeled 340, 510, 405, and 450. Each cell contains a numerical value representing a voltage. Below the table is a navigation bar with tabs: 'Reaction trend chart', 'Reaction data', 'Blank', and 'Action'. The 'Blank' tab is selected.

#	R1	R2	R3	R4	R5	R6	R7	R8	R9	R10	R11	R12	R13	R14	R15	R16	R17	R18	R19
340	50021	49432	48883	49235	49935	49958	49709	50175	49725	51104	48968	49833	50939	49122	49356	48982	49070	50004	48988
510	51362	51544	50509	51258	50866	51174	51587	51706	51451	51403	51772	51854	51591	50763	50820	50874	51163	50821	51521
405	50890	50885	49894	50653	50302	50591	50962	51029	50892	50902	50596	50932	50946	50204	49916	50280	50645	50287	50688
450	49226	49296	48489	49134	48720	48993	49375	49447	49330	49281	49255	49322	49344	48668	48450	48582	49041	48746	49237

Figure 5-41

5.5.4.4 Action

Shows current work steps, as shown in Figure 5-42:

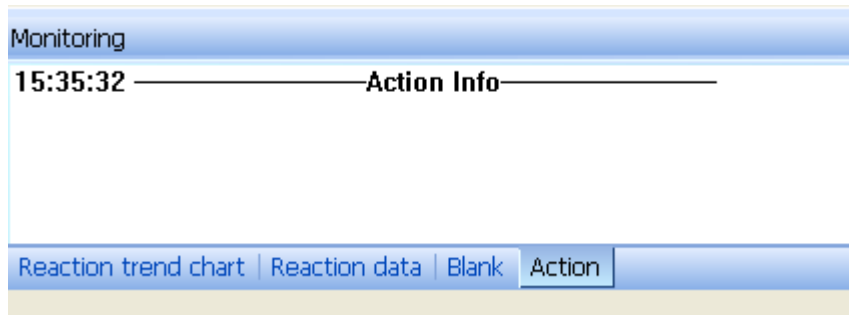

Figure 5-42

5.5.5 State bar

State bar with auxiliary function can be seen locked; the number keys locked, and screen locked state.

5.5.6 Language

Switch display language.

This software will display following languages when it is switched as shown in Figure 5-43; left side text is different with the main menu, because of left side text of the menu navigation is directly into the registry WINDOWS when the instrument is running. So a language is switched, text in the left menu will not, to fully realize language switch needs to remove registration information

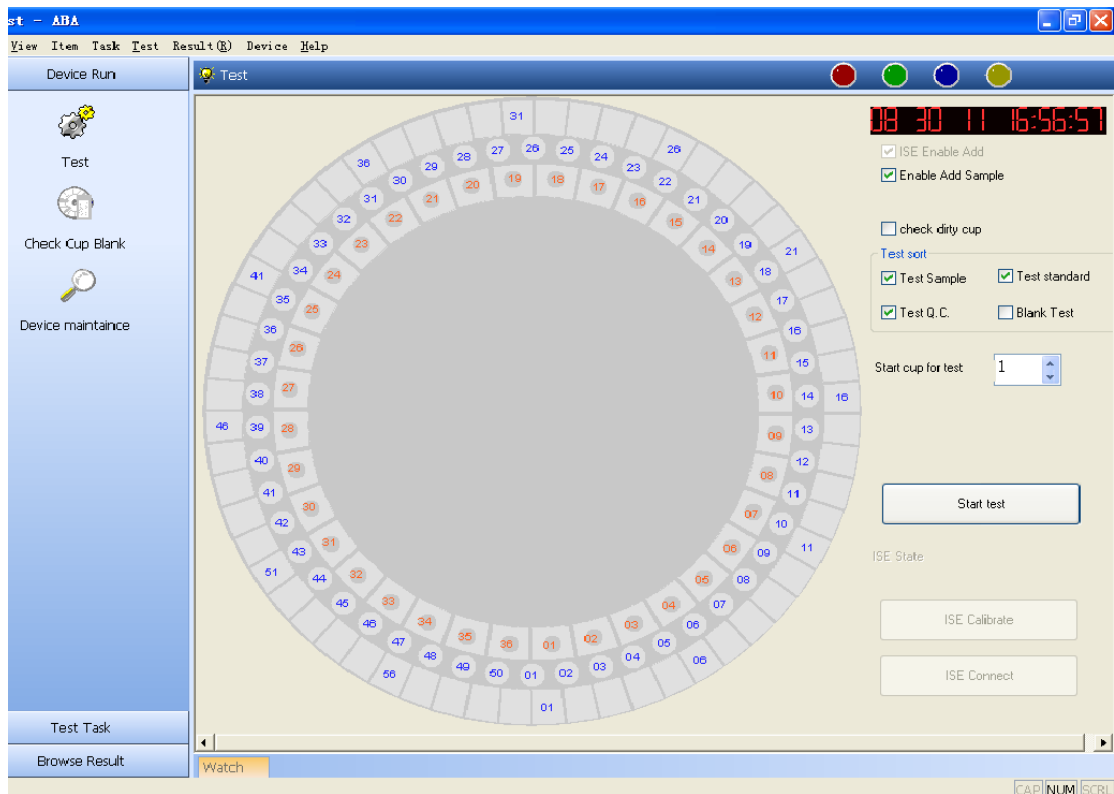

Figure 5-43

Ways for changing Spanish language interface into English interface in the navigation bar:

- 1, Select the menu "View \ Language \ English".
- 2, Close the software.
- 3, WINDOWS operating the registry order "Regedit" as following figure 5-44, delete all the BCGCO... items, see black box tips.
- 4, Run Software again to complete the switch in English.

From English interface to Spanish language interface as above.

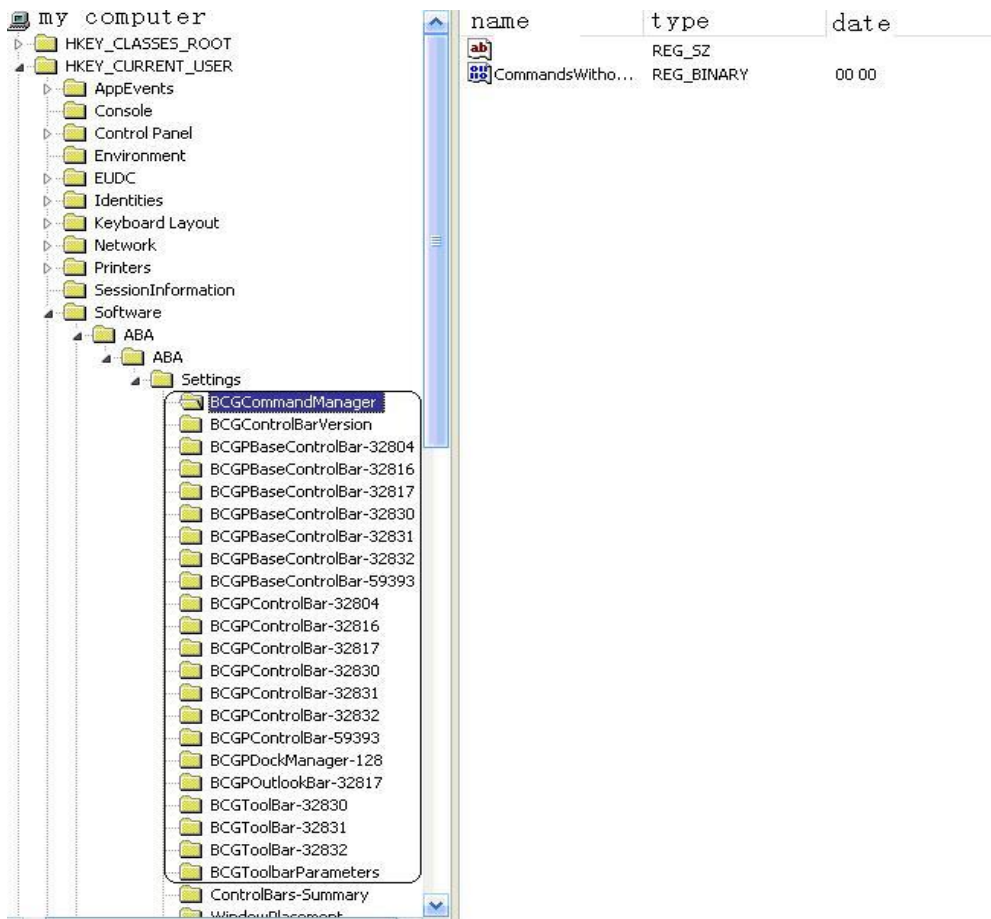

Figure 5-44

5.6 Item

5.6.1 Biochemistry item setup

Parameter setup of biochemical test is the first step for biochemical test, only correctly set up biochemical test parameters, to effectively guarantee the accuracy of test results.

Click the main menu "Item \ biochemistry item setup...", pop-up as follows as shown in Figure 5-45, interface need to check password:

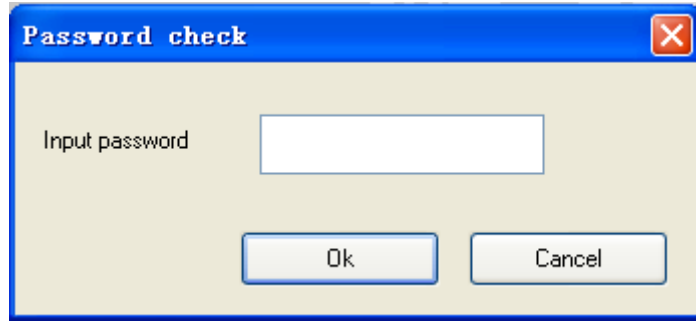

Figure 5-45

Enter a password 999, click “OK”, you can edit biochemical parameters, or not enter password, click “cancel” directly, can only query parameters, and can not modified. Enter password "999", the system pop-up window, as shown in Figure 5-46:

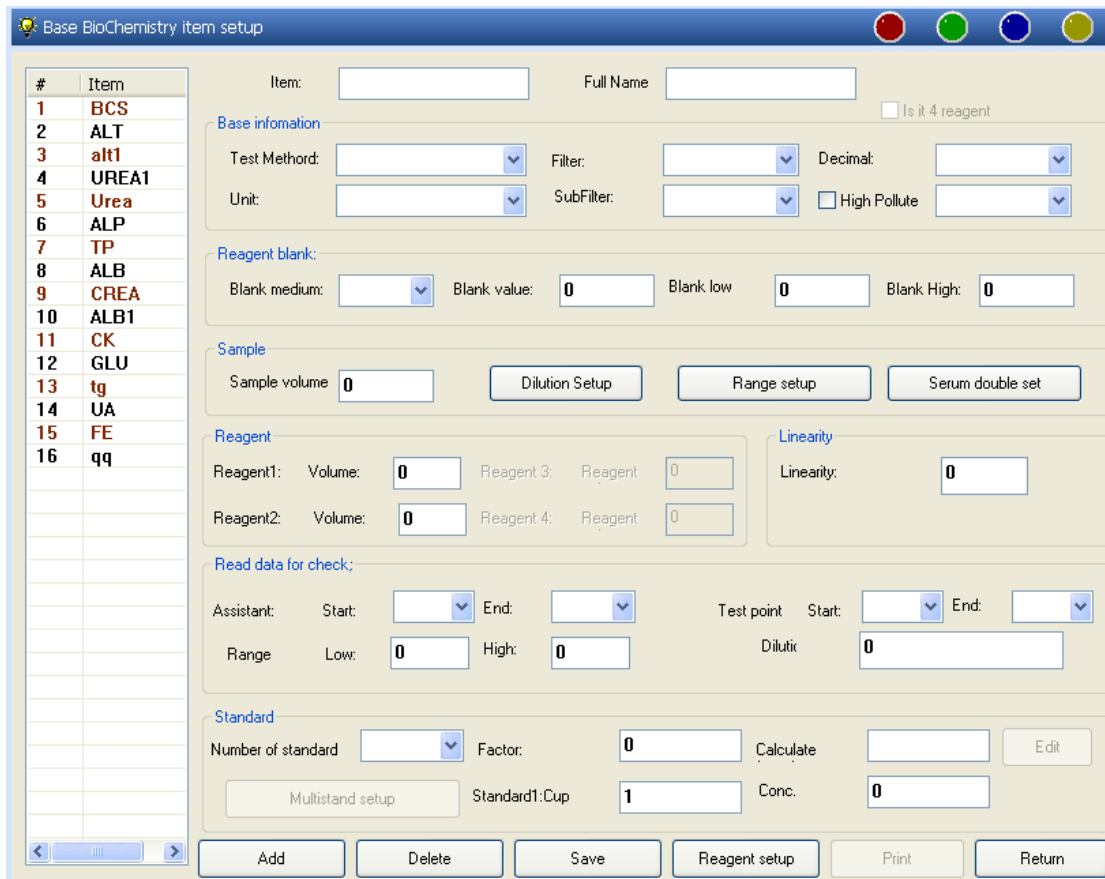

Figure 5-46

On the left side of the Basic biochemical item setup interface, show biochemical items are already in the database; the right is corresponding parameters of the items. In this menu can add, edit, print and delete test items.

Item names

Item: Full Name

Please enter the Item name and Full name.

Attention

- When input biochemical items, if item names include "-" symbols, rewritten "_" underscores symbols, in order to avoid confusing items in the calculation of the minus sign. For example, "r_GT" right;but "r-GT" wrong.

▲ Basic information

Base information

Test Method: Filter: Decimal:
 Unit: SubFilter: High Pollute

Test Method: **Super Kinetic** :

Click the drop-down menu, select item test methods. Methods include destination, speed, two points, super-end, super speed, super-two points, immune turbidity, multi-calibration, dual-wavelength and serum blank method.

Attention

- Linear range have to be set up correctly, zero is not allowed, the machines will achieve automatic dilution function under this condition.

Filter: : Click the filter, select requisite wavelength in the drop-down list

SubFilter: : General to None, when the choice of dual-wavelength testing, here to select the appropriate wavelength.

Decimal:

: To determine the decimal median reservations of the storage, display and print results, the select range is 0-4 bit.

Unit:

: Refer to the corresponding reagent manual to choose units.

High Pollute

: For high-pollution items, the checkbox of high pollute can be selected, and click the drop-down list to choose detergent. Cleaning pollution Item setup please see 5.6.5

Attention

- If you choose high-pollution cleaning, water and detergent must be placed correct position with hints.

▲ Blank medium

Reagent blank:
Blank medium: Blank value: Blank low: Blank High:

Blank medium:

: Click the drop-down list to select blank medium

Blank value:

: If it is not calibrated, the blank value must be zero. In addition blank value will be automatically saved when it is calibrated.

Blank low:

: Enter low value of blank medium; its value must be lower than blank

Blank High:

: Enter high value of blank medium; its value must be higher than blank low.

Attention

- If choose reagents as blank media and set the high and low blank value, for

determining the quality of reagents.

▲ Samples



Sample volume : The range of Sample absorption VS is 1-100 ul. Here, the range is proposed $VS \geq 2$ ul.

: The importation of the equipment automatically diluted multiples is generally $D \geq 2$.

1). Choose half dilution mode

Sample volume/ Dilution factor=testing amount; Test results automatically multiplied by the dilution factor; the default is 1, means does not dilute, the routine set is "2."

In "Run set of parameters" under "reaction panels," select "**half dilution**" mode, the relations between the largest number of diluted N and the diluted multiple D:

$$\text{Diluted sample } V_{\text{Dilution}} = VS_{\text{original sample}} / D^N \geq 1.6UL$$

2). Choose water dilution mode, as shown in figure 5-47:

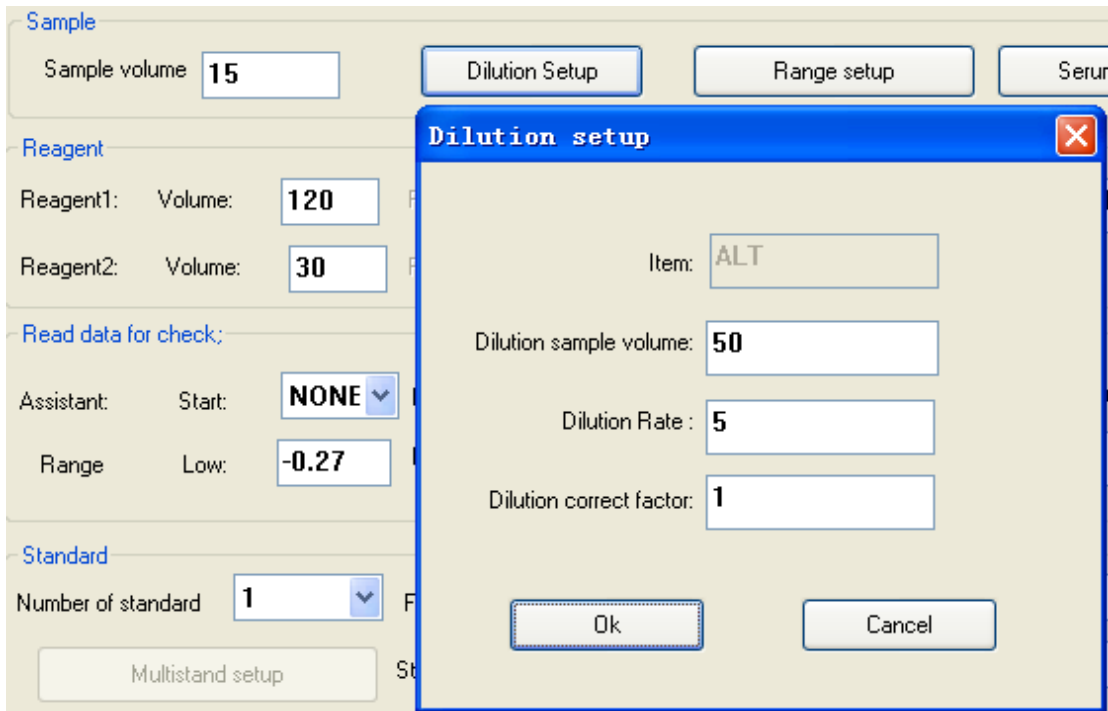

Figure 5-47

Sample dilution dosage is set to 50 ul, and dilution proportion is 5 times generally; If it needs big dilution proportion, that sample volume can reduce, and dilution proportion can increase. Diluted sample $V_{\text{Dilution}} = V_{\text{Original sample}} / D$ (Total volume is not changed, the serum volume is decreased $D * N$ times) .sample will be diluted by detergent first

Attention

- When setup dilution multiple, the sample amount can not less than 1.60 ul.
- Dilution mode, sample volume: 50ul, Diluted times:4 (50ul serum + 150ul diluents =200ul)

Dilution correct factor:

Used for results of correction factor that has been automatically diluted.

For example, ALT results for 300, diluted results for 310, so dilution correction factor can calculated for $300/310 = 0.967$.

Attention

- Dilution that the default value must be 1, can not be zero or any other characters.

Click this button to display the specific settings dialog, as shown in Figure 5-48:

Normal range setup

Item name:

Normal reference range

Low: High:

Reference range

#	Sex	Age low	Age high	Low	High

Add range

Sex:

Old range: -

Low: High:

ADD Save Delete Exit

Figure 5-48

Normal low-value and high-value are used for testing results which is low, normal or high. Steps for entering the reference range: firstly click "Add" and then enter the reference range, finally click "Save."

If certain reference range is needed to be canceled, and you can choose it and then click "delete" button. Save the item after exiting.

: Specific Settings as shown in figure 5-49:

Serum volume increase setup (kinetic)

Double Volume correct factor: 0.9

3 times correct factor: 0.8

4 times correct factor: 0.7

When the result is low than "Value Low concentration", it will increase double serum volume for test, if the result is low still, it will increase 3 times or 4 times serum volume for test

Low Value(kinetic): 5

Start double Volume

Conform Cancel

Figure 5-49

When the result is low than “Value Low concentration”, it will increase double serum volume for test, if the result is low still, it will increase 3 times or 4 times serum volume for test.

Attention

- For the normal range settings, should be based on reagent manual or local conditions to establish their own reference range.

▲ Reagents

Reagent

Reagent1: Volume:

Reagent2: Volume:

Reagent1: Volume: : Input requisite reagents volumes. It is the total volume of

reagents if use single reagent detection,. Input range is 1-500 ul. Recommendations: 6 mm cuvette 200-220 ul, 8mm cuvette 350-400 ul.

Reagent2: Volume: : Only double-reagent, the volumes of the second reagent, need to be entered, the range is 1-200 ul, the second reagent need not to be added when set it for zero.

▲ Linear

Linearity
Linearity:

Set up the linear range of reagents; please refer to the reagent manual. The result exceed linearity value , it will be automatic diluted

Attention

- To ensure the equipment to dilute and re-examine, please set accurate linear range, so zero is not allowed to set.

▲Reading of detection

Read data for check:

Assistant:	Start:	<input type="text"/>	End:	<input type="text"/>	Test point	Start:	<input type="text"/>	End:	<input type="text"/>
Range	Low:	<input type="text" value="0"/>	High:	<input type="text" value="2"/>	Dilutic	<input type="text" value="0"/>			

It is used for serum blank, kinetic method. Testing Methods such as the kinetic, which needs to be set "Assistant" and "Range". This feature is for reaction absorbance changes exceed the value of the absorbance set of "scope". "Auxiliary testing" starting point generally choose the fourth point after add serum and reagents. The number of assisted detection generally chooses five points. If the absorbance response to change in value is lower than the absorbance value set in the "Range", calculate results according to the normal points range setting of detection. Take ALT as an example, if you want to open it when auxiliary test results are above the linear range. Linear range: 500, the calibration factor: 1746, absorbance value calculation: $500 \times 60\% / 1746 = 0.1718$, the low absorption in the " Range " is set to: -0.1718, absorbance high value is set to: +0.1718. Testing

Methods such as the "End", choose the double reagent, and the serum as blank media, that is, test absorbance value in the 1-15 point range when the first reagent and serum are added. Usually select 1-3 in the 10-15 range, such as the choice of 10-11. Choose endpoint method", ultra-linear results will be automatically diluted.

Test point Start: End:

Optional scope of detecting points is 0-40. DS-161 effective detection point range as shown in Figure 5-50: Before starting detection point is the incubation period of time, the range of detecting point is reading point.

As an example for DS-161, set up checkpoints following steps: testing Period* Detection starting point= Incubation time .For example: testing method is end-point method, incubation time for five minutes, 14 seconds for the test cycle, and the testing start point is $5 \times 60 / 14 = 22$, Detection points generally choose 1-3 points from the 23rd point. Detection points more than 1 for the equipment will take average. If the testing end point is more than 40 after calculation, 40 points are elected. If the test methods is the rate or two-point method: Such as single-detection reagent recommended starting point is 12, the end point of detection 26, but should analyze different reagents response curve at the same time, select the appropriate detection point range. Two- reagent test for biochemical items, testing starting point should be set after 19:00.

Attention

- When test double reagents, it is called serum blank after adding reagents 1 and before adding reagent 2 to choose detect of points.
- Detection of points should be set up under response curves, find a linear, select the effective detection point above from the first point of adding serum.

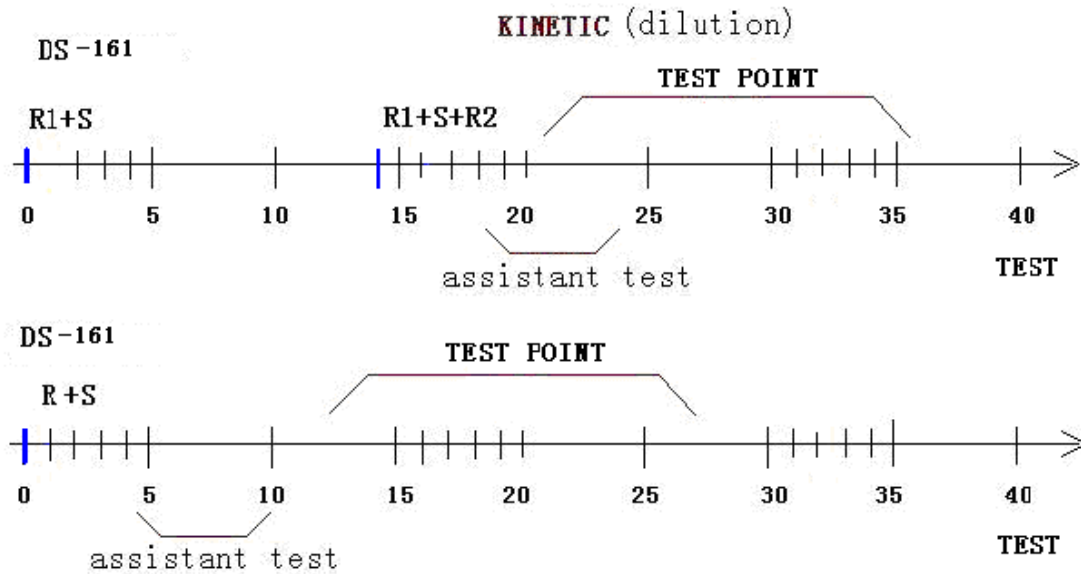

Figure 5-50

Take setting item CRE of DS-161 for example, as shown in Figure 5-51 as follows:

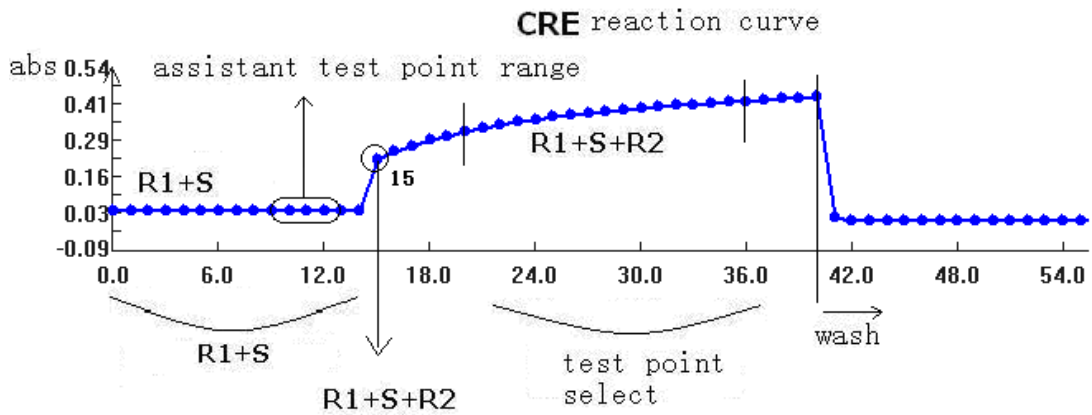

Figure 5-51

Half dilution process is shown below:

Take setting ALT Item parameters for example, $R1 : S=400 : 40$, diluted multiples of 4, auxiliary testing conditions $(\Delta A/Min) = -0.20 \sim +0.20$, the range is 500, As shown in Figure 5-52 as follows, P1 is reagents incubated time, P2 is assisted detection time, P3 for the detection of the time. First add the reagents, add samples from the 15th point, P2 is conditional of support detection, used to determine whether reaction is excessive, see if the equipment is automatically diluted, map of the Blue Line is the normal response curve, red color indicates that curve response is excessive, obviously results will be very high.

The judgment ways of the equipment: 1) in response test, when $|\Delta A / \text{sub}| < 0.20$, equipment use the normal test point P3 to test results; 2) when 0.20 of $P2 < |\Delta A / \text{Min}| <$ linear value $500/F$, P2 will be use of testing the results; 3) when $|\Delta A / \text{Min}|$ of $P2 >$ linear value $500/F$, four times the equipment is automatically diluted, and then re-judged by the above method; If after the four-fold diluting $|\Delta A / \text{Min}|$ of $P2 >$ linear value $500/F$, equipment will be diluted again, diluted $4^2=16$ times, if the maximum number N of diluting is 3, diluted multiples is D , the equipment can be diluted up to three times, maximum dilution multiple= D^N .

Detergent dilution mode is different, Sample will be diluted by detergent first,

Result = Result diluted* D

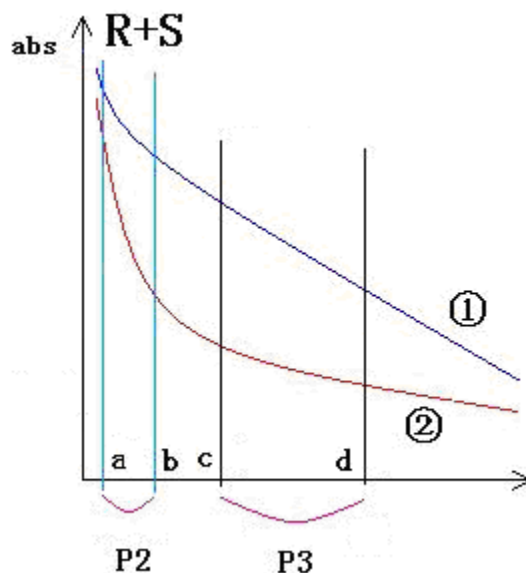

Figure 5-52

Attention

- Different equipments have different effective points for detection.
- If equipment has improvement, please take purchased equipments for standard.
- Kinetic method assisted detection point range= $\pm(\text{linear} * 60\% / F \text{ factor})$
- ▲ Standard

Standard

Number of standard Factor: Calculate Edit

Multistand setup Standard1:Cup Conc.

Number of standard : Calibration number is set for 1, which is single-calibration method or factor method, calibrations for the number 2 above shall be multi-calibration method.

Factor: : Enter calibration factor, initially use the item of rate method for the equipment, please enter the calibration factor with reagents statement, for other detection methods, may enter zero, the new calibration factor will automatically save after calibrating..

Calculate Edit : Edit the factor correction function.

Click the "Edit", interface displayed, as shown in Figure 5-53:

Figure 5-53

According to the actual situation for different testing items of the equipment, to revise the

calibration curve, set different power of the function, such as simple equation, Simultaneous Linear Equations, exponential equation, logarithmic equation, third power, n power ect.

Standard1:Cup : In accordance with samples location to enter calibration.

Conc. : Enter calibration concentration

: A multi-calibration settings.

When calibration numbers are more than 1, and click on the "Multistandard setup," interface, as shown in Figure 5-54:

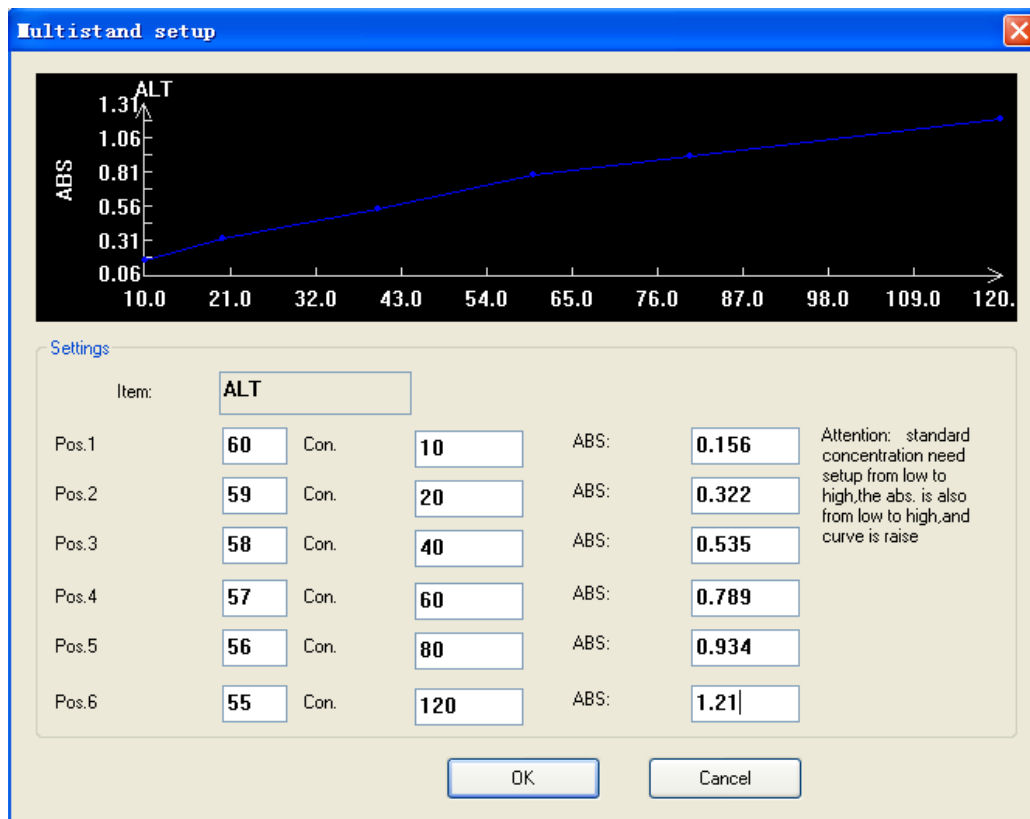

Figure 5-54

Enter corresponding numbers of cups and calibration concentration, click "OK" button.

Absorbance does not need input, after calibration, the system will automatically store corresponding absorbance value. In addition users can enter their own absorbance value, equipment will automatically draw calibration curve.

Attention

- Different items correspond to different calibrations cup places.
- The equipment is required for blank (reagents or distilled water) test firstly when testing calibrations, and then tests it.
- Multi-calibration item for testing calibrations, the equipment is required to be calibrated each calibration. In the use of multi-calibration, if they do not have calibrations, and would like to be used for detecting, the proposed do not enter 0. Enter 0.0002 is preferable, to avoid "0" calculation.
- Each set of calibration should be followed from low to high with orders

Add

Click to add a new set of parameters for the Item

Delete

To delete the existing biochemical detection Item. Select the item need to be removed from the left box of items list with "Ctrl" or "Shift" button, click "Delete" button.

Save

Set up the item parameters and click to save.

Reagent setup

See 5.6.6.

Print

Print the selected item.

Return

Back to Main menu

Attention

- After all items have been set up, please withdraw from the biochemical main program, and rerun the program, the system will automatically refresh database.

- Add a new item, should carry out corresponding reagent setting immediately, the item can be used normally.
- In the replacement of reagents, operator should pay attention to parameters setup of the item.
- When setup parameters of biochemistry item, please refer to the reagent manual.

5.6.2 Q.C. item setup

Control is used to check the test results are normal or not, it has low, medium and high value. Operating of control can Monitor Operation of analyzer and ensure the reliability of results. As shown in Figure 5-55 as follows:

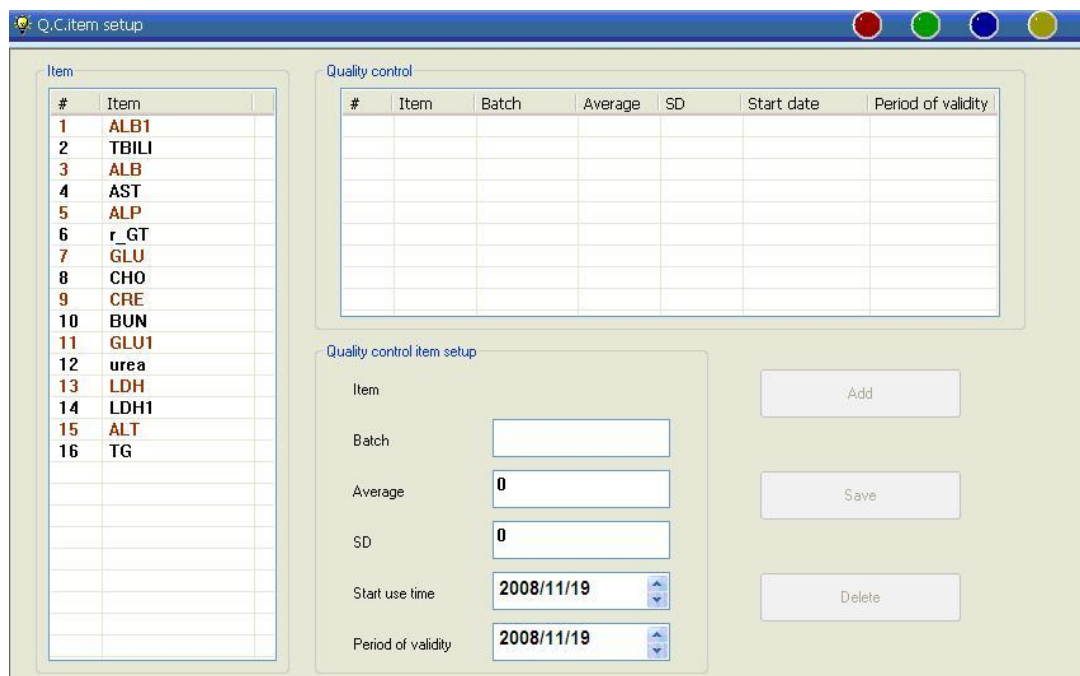

Figure 5-55

The steps of quality control are as follows:

1. Select biochemical items in the list, and then click "Add."
2. Input the batch number of quality control, typical value, calibration deviation, date of first use and valid period according to the system prompt.
3. Click "Save" button to save the control settings.

For deleting the control items, first select items which need to be deleted from

quality control list, and then click "Delete" button.

Attention

- Equipment can detect various controls without quantitative limitation.

5.6.3 Calculate item setup

Some results for biochemical test items need to be calculated for doctors to diagnose the patient, these calculated results are called the result of the calculation project, while these computing items written by biochemical formula named calculation item, as shown in Figure 5-56:

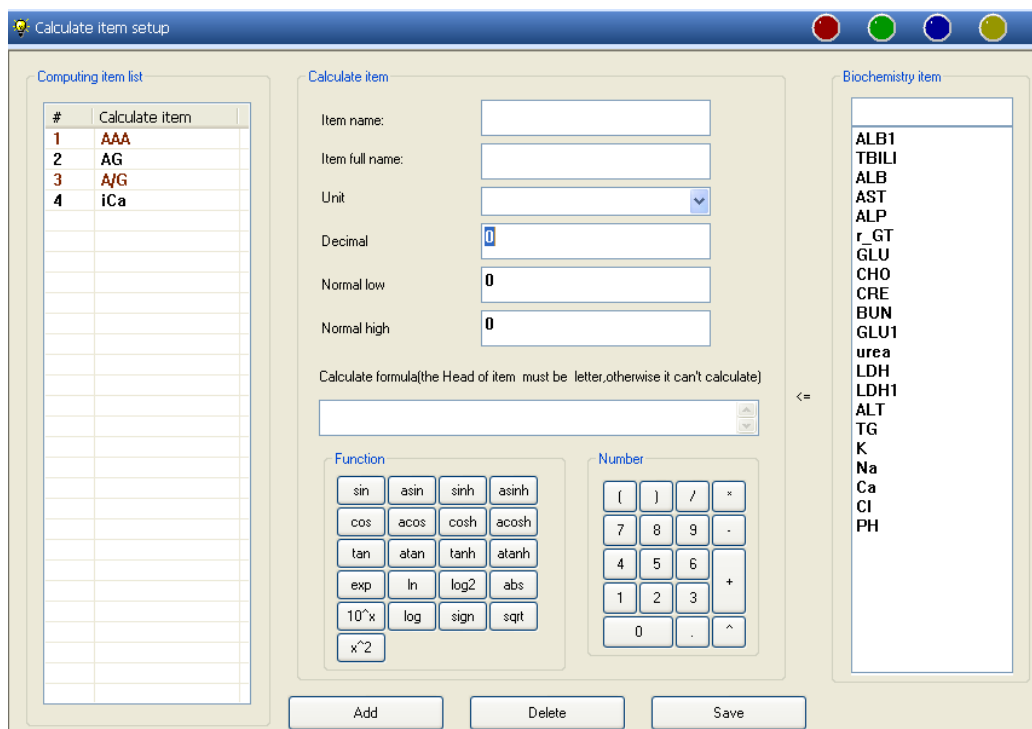

Figure 5-56

Steps of calculation item setup:

1. Click "Add".
2. According to the prompt to enter the item name, item full name, unit, decimals, normal high and low value.

- Set volumes of sample, reagent 1, reagent 2, and one cup has its own position..
- Click "Save" button to save.

For deleting pollution clean item, first select the item which is to be deleted in the list of pollution clean item list, and then click "Delete" button.

5.6.6 Reagent setup

Open the reagent Settings, then enter the password "999" and click "OK", as shown in figure 5-59

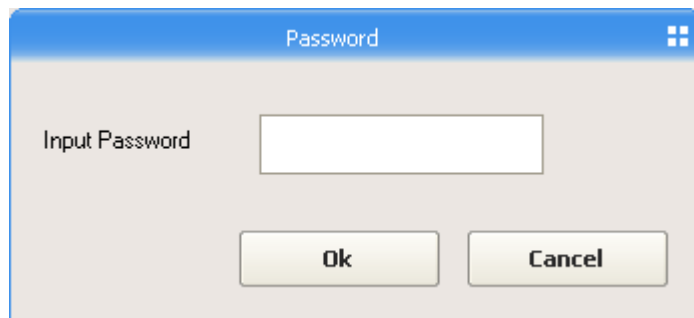

Figure 5-59

Reagent volume, and alarm valve etc, as shown in Figure 5-60:

Item	R1 Bar Code	R1 Pos	R1 All Volume	R1 Height	R1 Alm Gate	R1 Left times	R2 bar Code	R2 Pos	R2 All Volume	R2 Height	R2 Alm Gate	R2 Can test times
BC5		15	34000	30	5	80		16	34000	30	5	80
ALT		1	34000	30	5	67		3	34000	30	5	396
alt1		4	34000	30	5	48		20	34000	30	5	80
UREA1		20	34000	30	5	52	6923304712010	30	32000	39	5	76
Urea		28	34000	30	5	68	9233017110	29	34000	30	5	242
ALP		10	34000	30	5	135	6923304712010	21	34000	30	5	0
TP		36	34000	30	5	104		0	34000	30	5	14
ALB		2	34000	30	5	67		0	34000	30	5	80
CREA		6	34000	30	5	107		18	34000	30	5	332
ALB1		2	34000	30	5	39		20	34000	30	5	80
CK		21	40000	75	5	79		22	34000	70	5	80
GLU		23	40000	75	5	21		29	34000	70	5	80
tg		24	40000	75	5	18		0	34000	70	5	80
UA		25	40000	75	5	58		23	16000	75	5	80
FE		1	32000	39	5	2153		20	32000	39	5	74
qq		29	32000	39	5	80		20	32000	39	5	80
DILUTION		22	40000	75	5	6		1	0	75	0	0

Barcode setup:
 Don't change interface during scan barcode!!!

Single scan: Cup No.:
 Reagent 1 Reagent 2 4 Reagent

Figure 5-60

The settings of relevant information: reagent 1, reagent 2, alarm threshold, total reagent, and reagent bottle height etc.

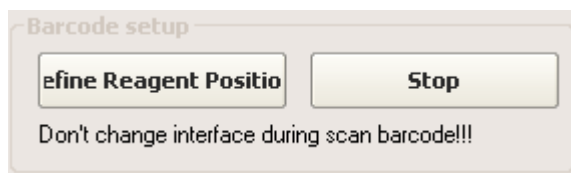

: For scanning the reagent plate, and it will define the barcode information to the reagent position.

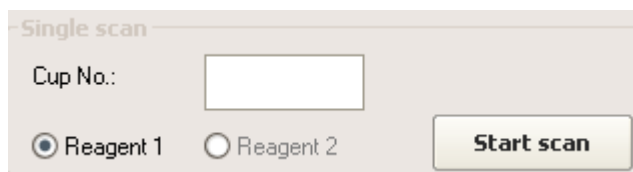

: For scanning the reagent position of the "Cup No.", and it will define the barcode information to the reagent position.

Detection reagent button can test excess of Reagent 1 and Reagents 2 to obtain current reagents information.

Attention

- As the equipment can use two sizes reagent bottle according to need, the total and the height of the reagents must be entered.
- The alarm threshold of Reagent 1 and Reagents 2 means alarm when test reagent is less than this value, yellow alarm and sound alarm tips will appear, so in order to hear this buzzer it is required to connect the computer speakers.
- After setting up new biochemical items, reagents should be setup immediately, especially the total of reagents, the height of reagent bottle and alarm threshold should be set first, then the item could be used normally, otherwise not test after starting the equipment.

5.6.7 Other setup

5.6.7.1 Item compositor

Through sorting of the test items, to realize the order of the item display and testing, as

shown in Figure 5-61:

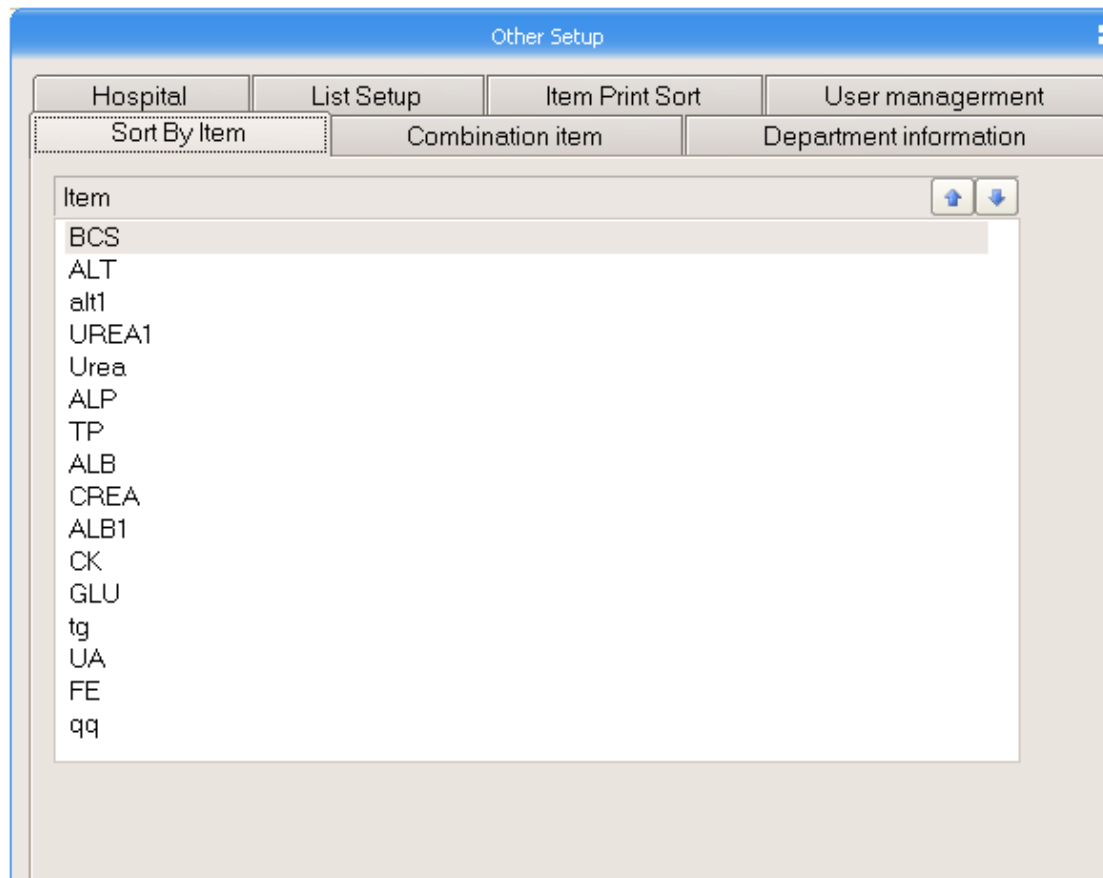



Figure 5-61

: Button for adding.

: Button for deleting.

: Button for sorting.

Take the reagents of SINNOWA for example, recommended detection order: ALT、AST、CK、LDH、HBDH、Urea、AMY、P、GGT、ALP、TG、LA、UA、HDL-C、LDL-C、GLU、CHOL、CK-MB、ApoA-I、ApoB、FMN、TP、Ca、Mg、CL、ALB、Crea、DBILI、TBILI.

Principles of compositor:

1. Separate strong acid reagent from alkali.
2. Separate antibody from the non-antibody reagents.
3. Put reagents together based on the same reaction principle, such as Trinder.

4. Select wavelength by steps, with the best order of 340-800 nm to assemble for testing.

Reagent classification

Strong acid reagents: ALB、CL

Weak acid reagents: GLU、CHO、TG、AMY、CK、CK-MB、HDL-C、LDL-C、LACTATE、TBILI、DBILI、P

Weak alkaline reagents: ALT、AST、UREA、GGT、LDH、HBDH、ApoA、ApoB、UA

Strong alkaline reagents: ALP、CA、Mg、TP、CREA、FMN

Attention

- Sorting of detected item can solve cross-contamination problems among the different items; operators can set it by themselves.

5.6.7.2 Combination items

During biochemical tests, some test items should be combined together to form a combination of biochemical test items, it is known as the "combination item", as shown in Figure 5-62, all the biochemical test items of the database is shown in the right list box, the left list box shows the combination of test items name which has been entered by users.

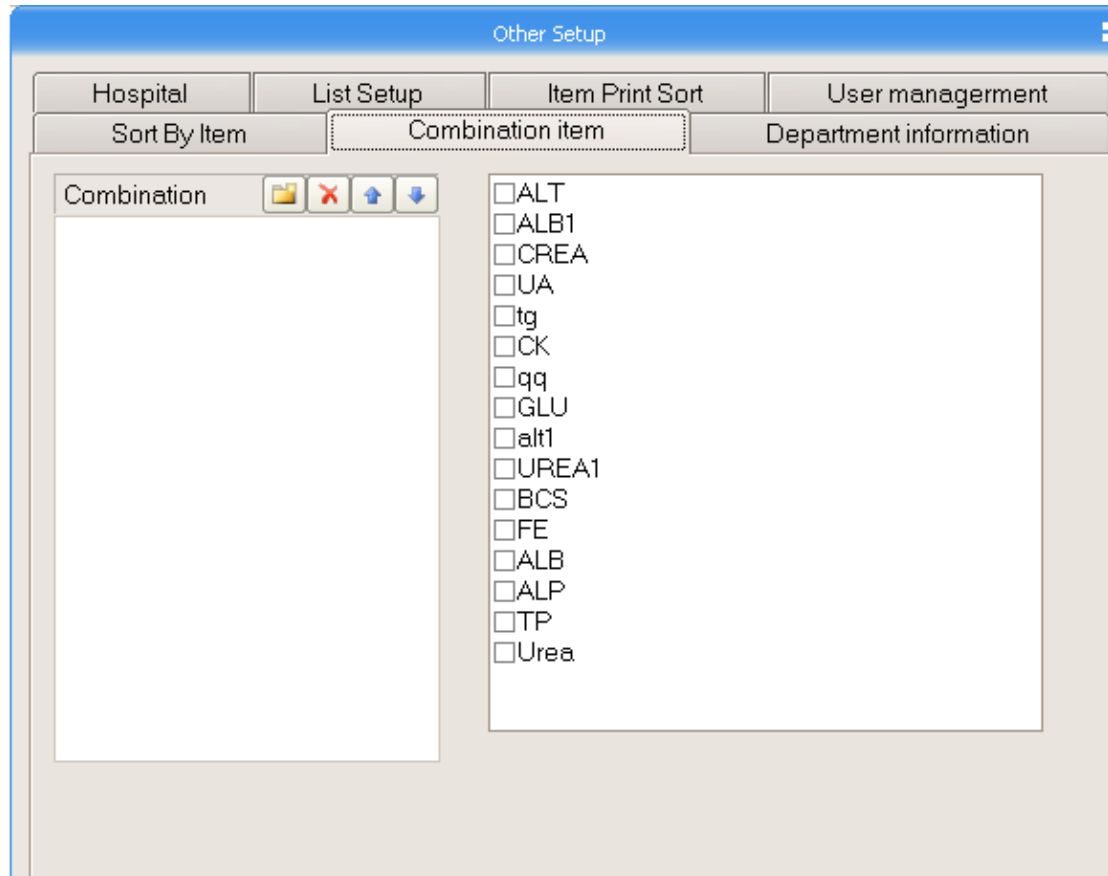





Figure 5-62

: Button for adding.

: Button for deleting.

: Button for compositor.

For example, "TG", "CHO" combination of the two items as "blood lipid", a combination of the items. Operation methods are as follows: first, click "add" button, and then enter name of combination item, "blood lipid", and then select checkbox before "TG" and "CHO" on the right list box.

5.6.7.3 Hospital

The name of the hospital, departments and doctors can be set here; the name of hospital is a title of the report, as shown in Figure 5-63:

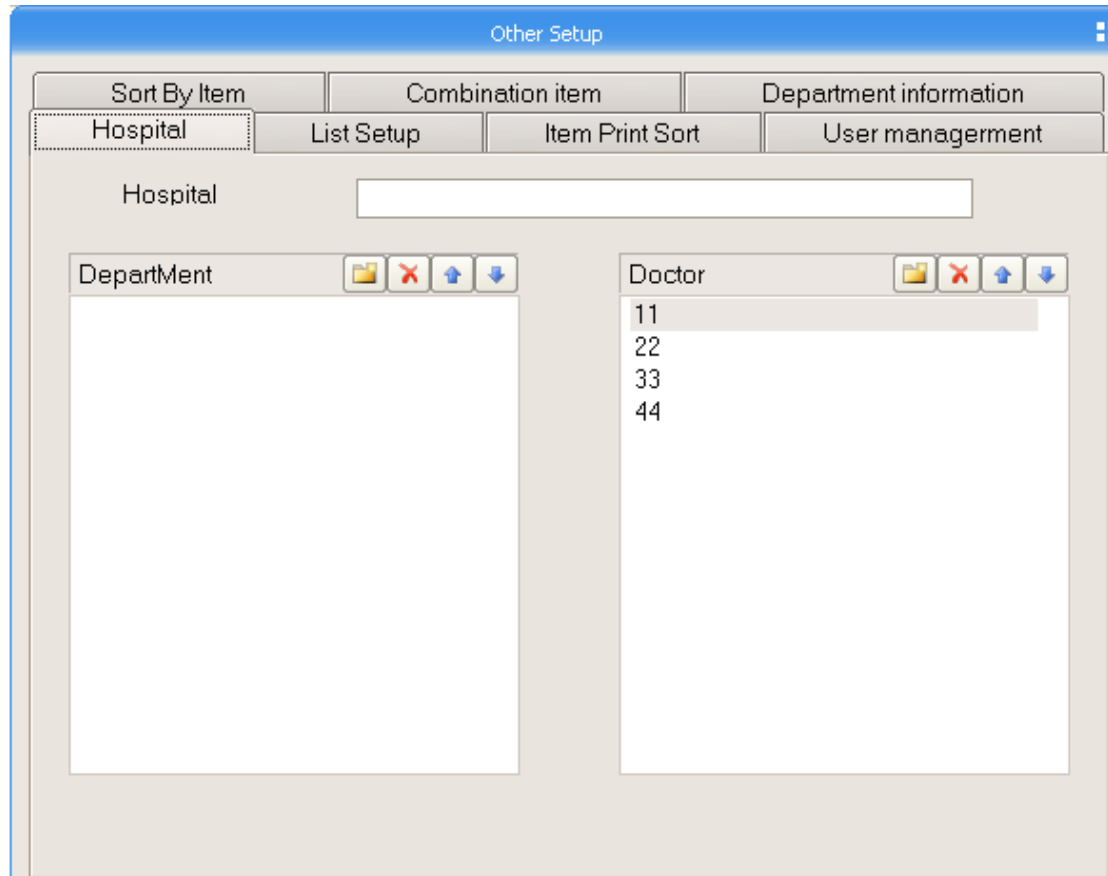





Figure 5-63

: Button for adding.

: Button for deleting.

: Button for compositor

5.6.7.4 Down-list setup

Sex, type of samples, unit, diagnosis, remarks and etc can be set in this menu, as shown in Figure 5-64:

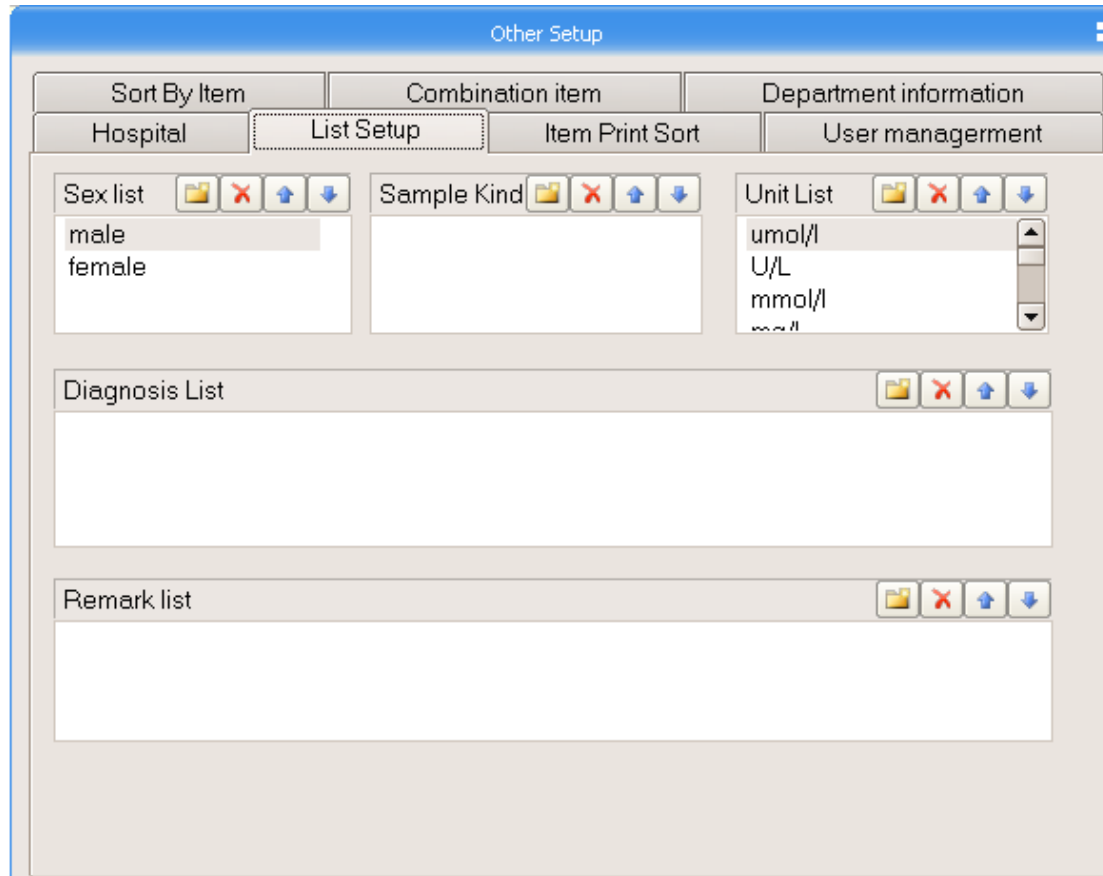





Figure 5-64

: Button for adding.

: Button for deleting.

: Button for compositor

Attention

- Set parameters above, the length of the characters is at most 50.

5.6.7.5 Item print order

Settings of print order, as shown in Figure 5-65:

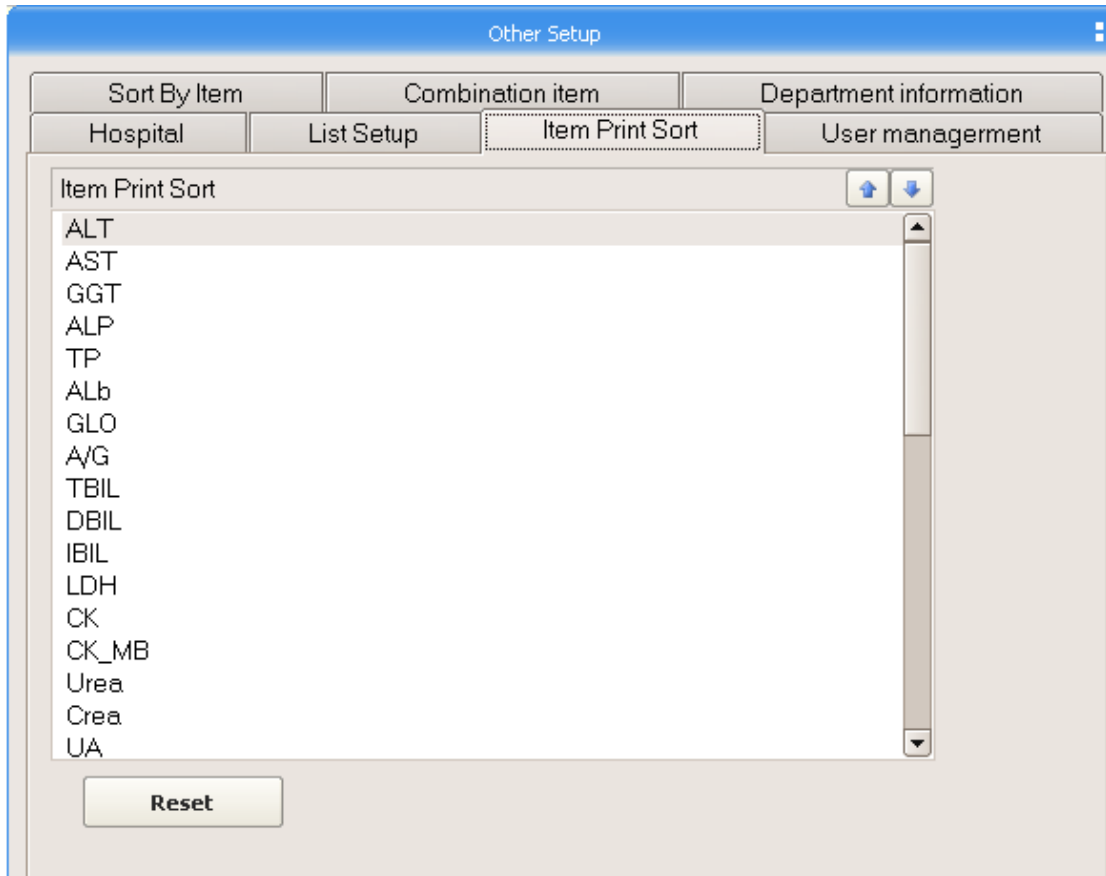



Figure 5-65

Detailed steps are as follows:

- Click "Reset" button. New added items can be showed.
- Click adjusted items in the biochemical item list.
 1. Click  button for sorting.

5.6.7.6 User management

System requirements laboratory personnel enter a name for printing and working registration, 3-level privileges for users: administrators, maintenance man, operators, as shown in Figure 5-66:

Set the department name and the doctor's name of hospital in "5.6.7.3 hospital", then choose the involved doctors name from the department in the "department information set", as shown in figure 5-67:

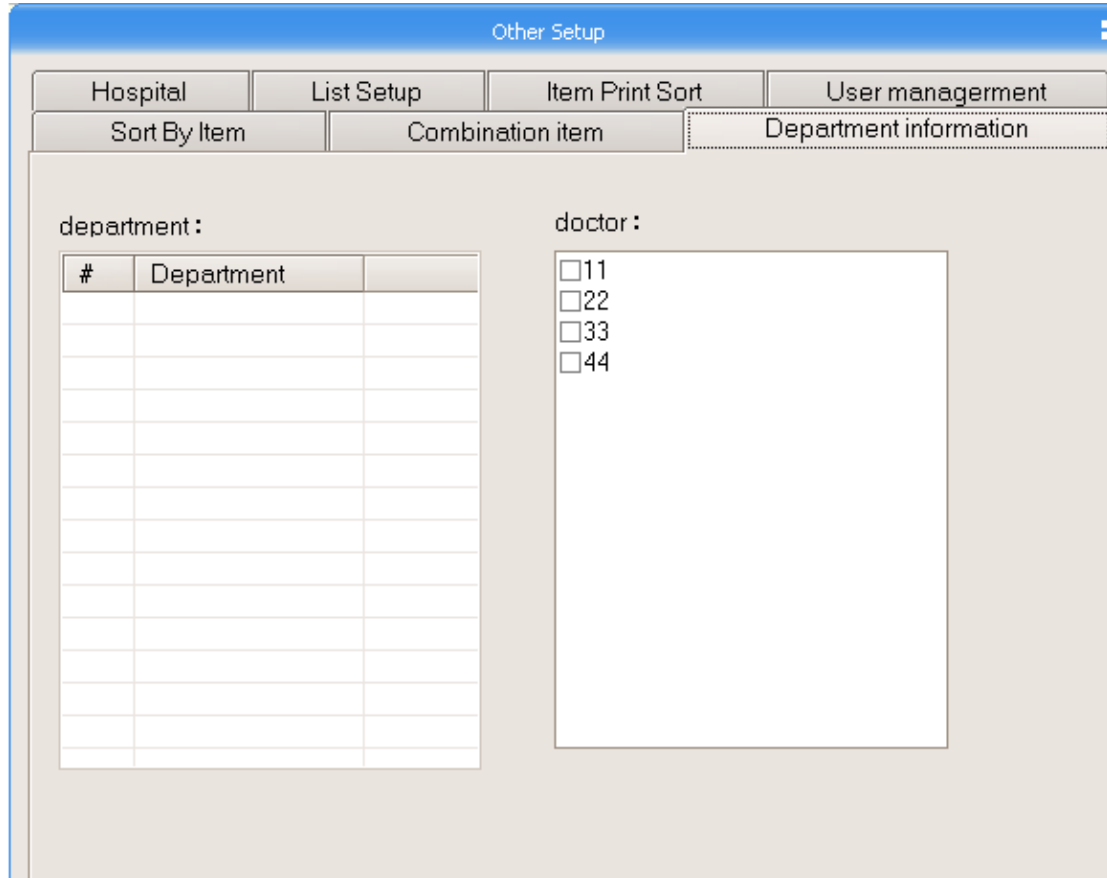

Figure 5-67

5.6.8 "One button" combination action setup

"One button combination action setup" is to define a series of process of start-up and shut down as a combination of action, click composite move in "Device run \ Device maintenance" to take combination maintenance, as shown in Figure 5-68:

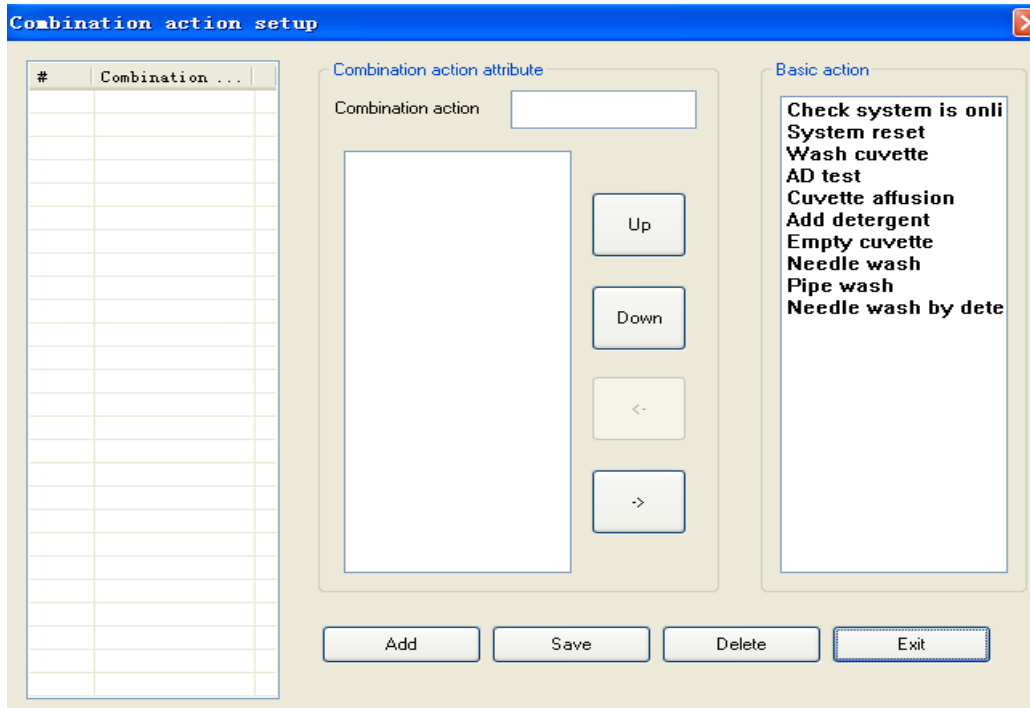

Figure 5-68



: The order of basic movements in upward combination moves adjustment.



: The order of basic movements in downward combination moves adjustment.



: Add the basic movements to portfolio action list from the list of basic moves.



: Action of the basic moves out of the combination list.

Steps of adding a combination action are as follows:

1, Click "Add" button.

2, Enter the name of combination actions.

3, Select the basic movements from the basic action list, clicks , to form a combination of actions.

4, Click "Save" button to be recognized and preserved.

Attention

- While set combination action, "Blank test" must be placed after the "Affusion".

5.6.9 Blank display

This menu can be used to show reaction cups, in which the blue tips that the absorbency is out of range (>0.025), large differences among the related cup, reaction cup needs cleaning again, red hints that voltage value of reaction cup is too low (<30000), needs to be changed, or voltage value is too high (>62000), voltage is need to be adjusted, “-1.0000 “ means there isn’t filter ,as shown in Figure 5-69:

#	340nm	510nm	405nm	450nm	546nm	578nm	620nm	670nm	650nm	700nm	750nm	810nm
1	-0.0015	-0.0002	-0.0013	-0.0006	-0.0009	-0.0007	-0.0008	-0.0006	-1.0000	-1.0000	-1.0000	-1.0000
2	0.0043	-0.0019	-0.0012	-0.0013	-0.0009	-0.0007	-0.0009	-0.0011	-1.0000	-1.0000	-1.0000	-1.0000
3	0.0098	0.0081	0.0085	0.0069	0.0058	0.0056	0.0047	0.0033	-1.0000	-1.0000	-1.0000	-1.0000
4	0.0063	0.0008	0.0010	0.0004	0.0010	0.0009	0.0009	0.0007	-1.0000	-1.0000	-1.0000	-1.0000
5	-0.0007	0.0046	0.0045	0.0045	0.0020	0.0034	0.0033	0.0033	-1.0000	-1.0000	-1.0000	-1.0000
6	-0.0009	0.0016	0.0016	0.0018	0.0007	0.0006	0.0004	0.0005	-1.0000	-1.0000	-1.0000	-1.0000
7	0.0016	-0.0023	-0.0020	-0.0020	-0.0005	-0.0010	-0.0013	-0.0011	-1.0000	-1.0000	-1.0000	-1.0000
8	-0.0030	-0.0035	-0.0026	-0.0028	-0.0023	-0.0025	-0.0020	-0.0017	-1.0000	-1.0000	-1.0000	-1.0000
9	0.0014	-0.0010	-0.0013	-0.0016	0.0016	-0.0005	-0.0008	-0.0006	-1.0000	-1.0000	-1.0000	-1.0000
10	-0.0121	-0.0006	-0.0014	-0.0011	-0.0007	-0.0007	-0.0005	-0.0005	-1.0000	-1.0000	-1.0000	-1.0000
11	0.0090	-0.0041	0.0016	-0.0008	-0.0012	-0.0032	-0.0033	-0.0031	-1.0000	-1.0000	-1.0000	-1.0000
12	0.0003	-0.0030	-0.0017	-0.0015	-0.0008	-0.0007	-0.0008	-0.0002	-1.0000	-1.0000	-1.0000	-1.0000
13	-0.0105	-0.0024	-0.0018	-0.0017	-0.0038	-0.0016	-0.0016	-0.0010	-1.0000	-1.0000	-1.0000	-1.0000
14	0.0074	0.0056	0.0054	0.0051	0.0045	0.0047	0.0047	0.0046	-1.0000	-1.0000	-1.0000	-1.0000
15	0.0051	0.0070	0.0083	0.0073	0.0049	0.0054	0.0061	0.0060	-1.0000	-1.0000	-1.0000	-1.0000
16	0.0088	0.0045	0.0047	0.0059	0.0075	0.0046	0.0055	0.0044	-1.0000	-1.0000	-1.0000	-1.0000
17	0.0080	0.0017	0.0011	0.0013	0.0032	0.0008	0.0018	0.0018	-1.0000	-1.0000	-1.0000	-1.0000
18	0.0014	0.0051	0.0040	0.0040	0.0010	0.0014	0.0007	0.0000	-1.0000	-1.0000	-1.0000	-1.0000

— Voltage out of range
— Filter voltage out of

Buttons: Voltage/absorb, Ok

Figure 5-69

Attention

- In "Hardware", the settings of cup voltage range and reaction cup's filter:

“blankODFilter=0.025

blankVotageMax=62000

blankVotageMin=30000”

- To use the same batch reaction cup as much as possible, this can reduce differences among the cups.

5.7 Task

5.7.1 Add sample

See 5.5.2.2.1

5.7.2 Add standard

See 5.5.2.2.2

5.7.3 Add Q.C.

See 5.5.2.2.3

5.8 Test

5.8.1 Biochemistry test

See 5.5.2.1.1

5.8.2 Blank test

See 5.5.2.1.2

5.8.3 Stat and check reagent

Stat and probe reagent are to detect the remaining amount, as shown in Figure 5-70:

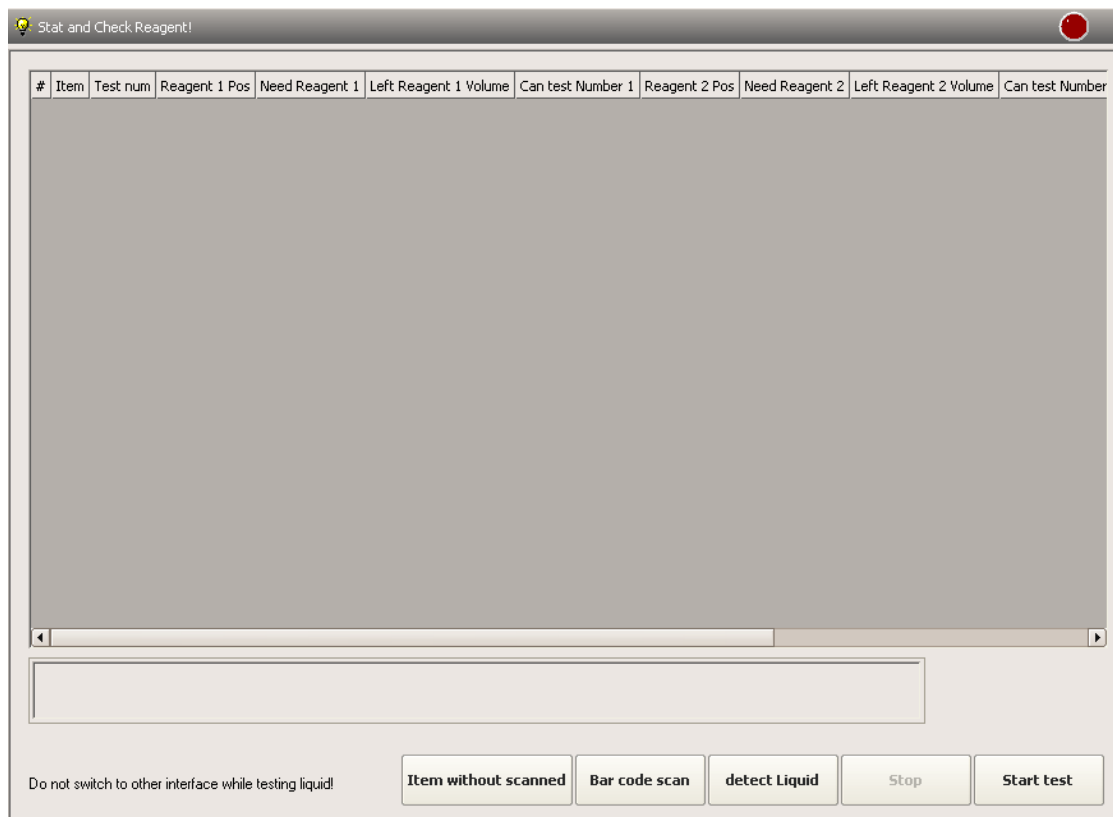

Figure 5-70

Add the test item; click "Start test" button to enter the reagent statistical detection interface, the interface can detect the remaining amount of reagent. If the equipment has installed bar code scanners, it can be adapted "barcode scan" confirmation of reagents. After finishing detection of reagent and then click "Start test" begin testing tasks.

Attention

- Level detection is forbidden for being switched into other interface, or level detection will be terminated.

5.9 Result

5.9.1 Sample result

.See 5.4.2.3.

5.9.2 Calibration result

See 5.4.2.3.2

5.9.3 Q.C. result

See 5.4.2.3.3

5.9.4 Results analysis

Analysis with results data can analyze samples, calibrations and control test results, and provide computing function as well, shown as Figure 5-71:

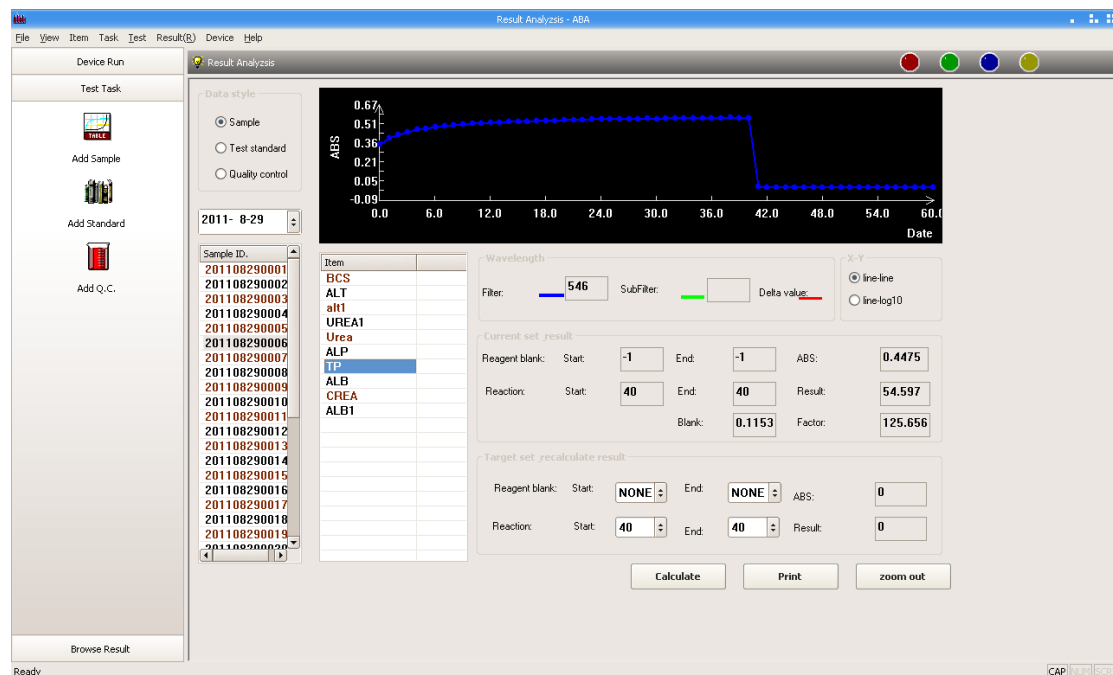

Figure 5-71

Steps are as follows:

1. Choose date for data analysis
2. Select types of data.
3. Select sample ID in the list, the corresponding test items will appear in the item list.
4. Choose the item which is required to be analyzed, wavelength, test results and other information will be shown for the item.
5. If the absorbance for reagent blank and reaction results are needed to be recalculated, the detection point range should be set, and then click "calculate",

Attention

- After finding appropriate detection point, the range of checkpoints should be reset in "" Biochemistry item setup".

5.9.5 Item result

See 5.4.2.3.4

5.9.6 Send result

The results send function is a button can send the results to other computers, as shown in Figure 5-72:

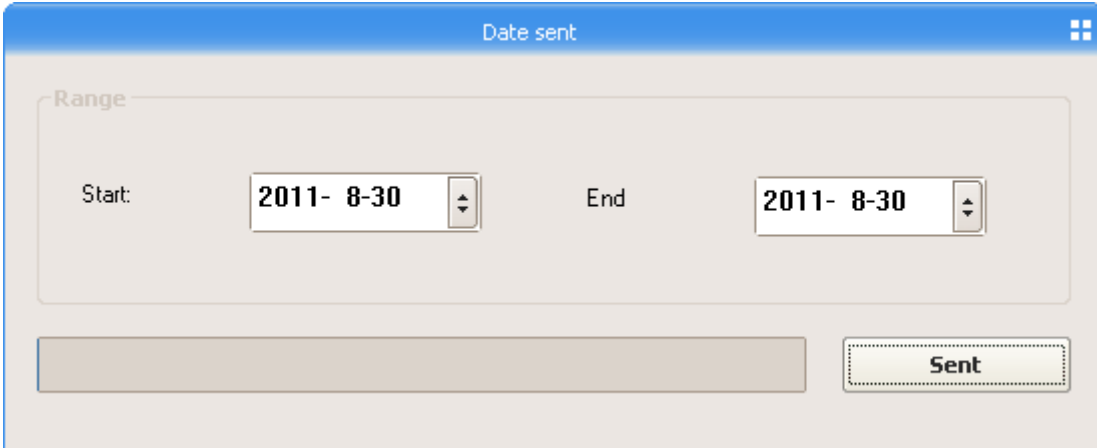

The screenshot shows a window titled "Date sent" with a blue header bar. Inside the window, there is a "Range" section. Under "Start:", there is a date input field containing "2011- 8-30" and a small dropdown arrow. To the right of "End:", there is another date input field containing "2011- 8-30" and a small dropdown arrow. Below these fields is a large, empty rectangular area. To the right of this area is a button labeled "Sent" with a dotted border.

Figure 5-72

When send the intraday results, the time range please inputs the day until the next day.

5.10 Device

5.10.1 Device maintenance

See 5.5.2.1.3

5.10.2 Force stop test

When the equipment is running, "force stop test" button can stop all movements without any reason for an emergency. As shown in Figure 5-73 as follows:

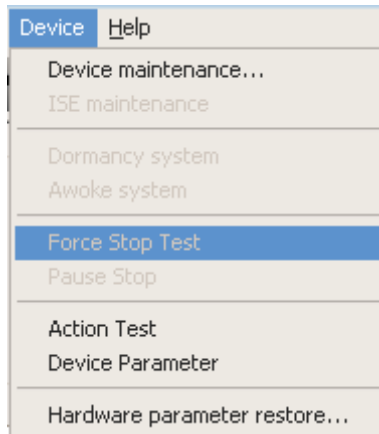

Figure 5-73

Attention

- “Force to stop test” should be used cautiously; otherwise, added reactant will not be able to resume testing.

5.10.3 Pause test

This function can be used for delaying working time for the equipment, reagents can placed during time and serum, within 20s, as shown in Figure 5-73 above:

Attention

- Use "pause test" will prolong testing cycle, and affect results.

5.10.4 Action test

As an administrator or a maintenance man, who is able to enter this interface, as shown in Figure 5-74, for testing each component actions to solve malfunctions for the equipment.

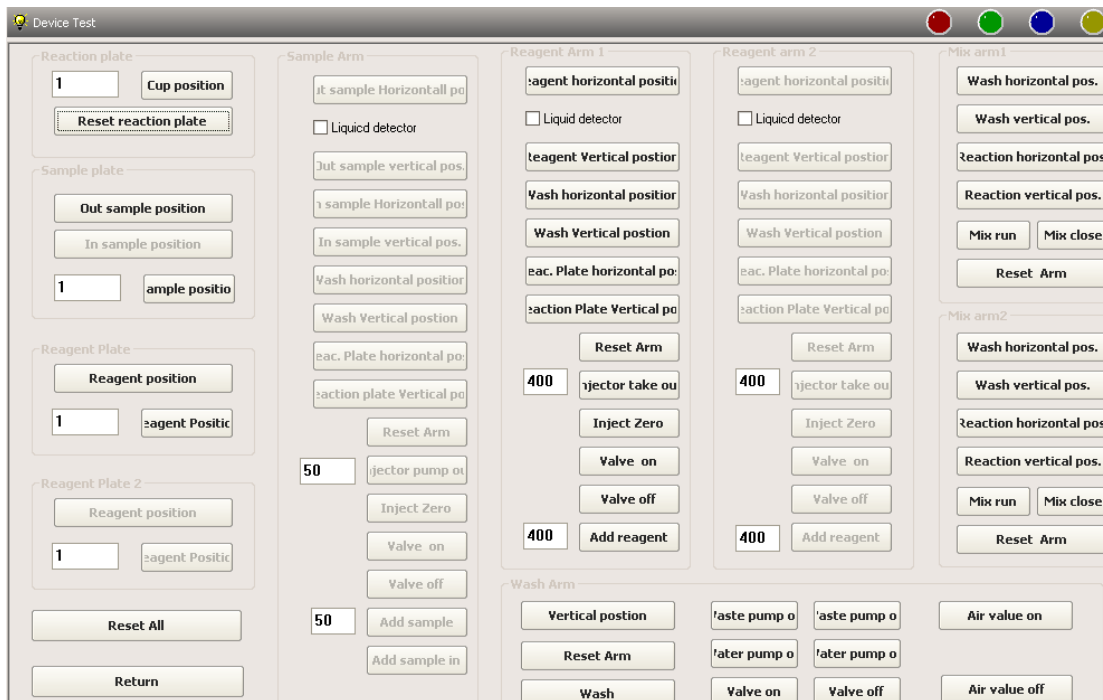

Figure 5-74

Equipment testing take “sample plate” position detection as an example, click "outer sample position " sample plant to reset, such as input "5" and then click "samples position," at this time the 5th sample is returning to the original position.



- Positions for sample arm, reagent arm, stirring arm, which must follow first horizontal, then vertical, the last reduction. Otherwise, probes easy to be damaged.

5.10.5 Device parameters

Set up operation parameters for the equipment hardware accurately, can avoid touch-phenomenon and equipment damage when the equipment is running. The system provides a series of motor movement parameters for reference, when equipments leave factory, motor movement and corresponding parameters have been set up; because of transportation and other reasons, probes positions may be a slight shift, they need to make proper adjustments. The following details various functions of the settings column: input Password: 999,, shown in Figure 5-75:

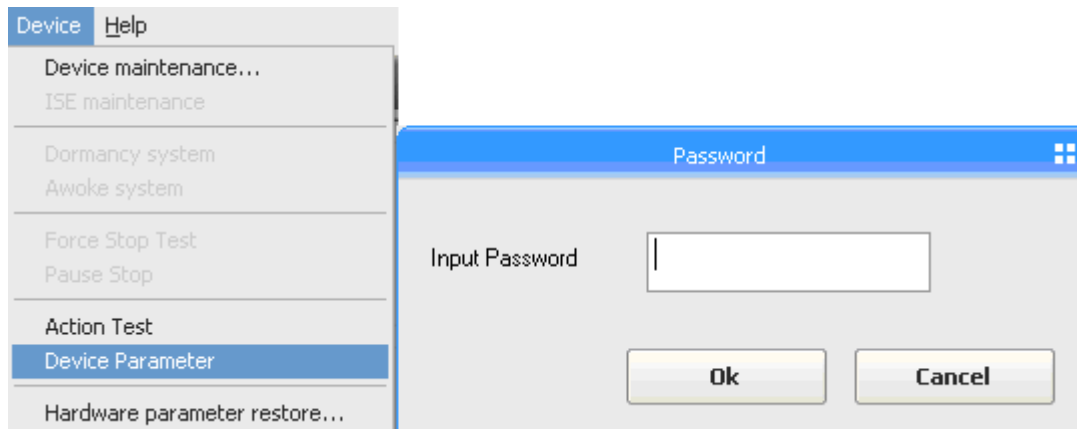

Figure 5-75

5.10.5.1 Device

Open the biochemical analyzer operating parameters and then enter the password "999" and click "confirm" and interface is shown in Figure 5-76:

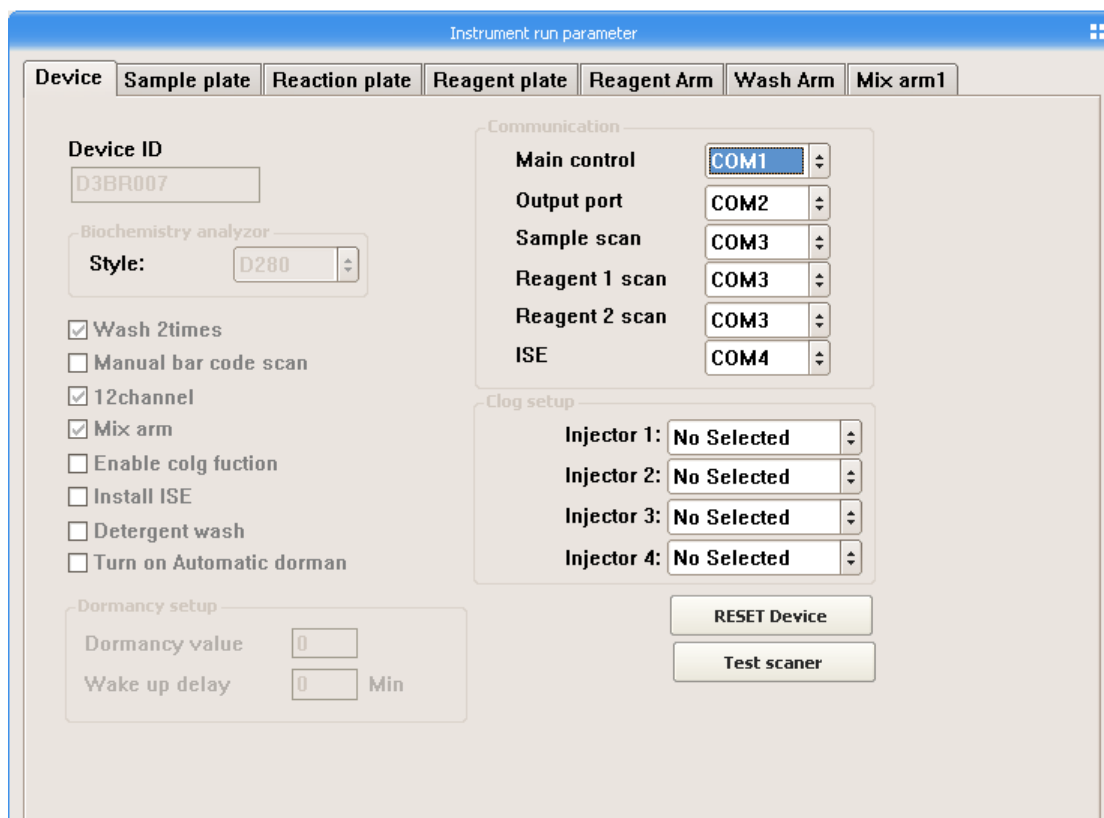

Figure 5-76

The software supports all the DS Series automatic biochemical analyzers produced by

SINNOWA.

Setup as follows:

"twice-washing": clean cuvettes twice, the serious pollution items proposed for it.

"Manual barcode scan": can use scanner to scan samples and add reagents by hands.

"12-channel": selected it for 12-channel motherboard, if not for 8-channel.

"Mix arm": selected it for an independent mixing probe, or not without a independent mixing probe.

"Open anticlogging": choose it, the probe will have anticlogging function.

"Install ISE": select it means built-in electrolyte is built

"Add detergent": select it means detergent cleaning function is added at cleaning head.

"Start auto -dormancy": means the instrument can enter dormant to protect light source

Communication: set up communications ports of the hardware with it, serial port of the main board is COM1.

"Anticlogging setting": show responding relationship between diluter and probes.

Attention

- If the instrument equips a bar code scanner, reagents and samples should have the same serial port scan.
- Lack of the computer serial ports, expansion cards s can be loaded.

Warning

- Above parameters for the instrument hardware configuration decisions, not allow changing freely, otherwise the equipment can not be used.

5.10.5.2 Reaction plate

Settings of reaction plates parameters, as shown in Figure 5-77:

Instrument run parameter

Base parameter

Control Board Address:

Motor start speed:

Motor run speed:

Temp of reaction plate:

First needle of washArm:

Last needle of washArm:

Position of add sample:

Position of Add reagent:

Position of Add reagent 2:

Mix1 pos.:

Mix2 pos.:

Diameter of light:

Cycle of Test:

Filter_Sensor

No.	WaveLength	Position
1	<input type="text" value="340"/>	<input type="text" value="14"/>
2	<input type="text" value="405"/>	<input type="text" value="14"/>
3	<input type="text" value="450"/>	<input type="text" value="14"/>
4	<input type="text" value="505"/>	<input type="text" value="14"/>
5	<input type="text" value="546"/>	<input type="text" value="14"/>
6	<input type="text" value="578"/>	<input type="text" value="14"/>
7	<input type="text" value="620"/>	<input type="text" value="14"/>
8	<input type="text" value="670"/>	<input type="text" value="14"/>
9	<input type="text" value="0"/>	<input type="text" value="1"/>
10	<input type="text" value="0"/>	<input type="text" value="1"/>
11	<input type="text" value="0"/>	<input type="text" value="1"/>
12	<input type="text" value="0"/>	<input type="text" value="1"/>

action test

Cup: ->

select item

Save Check data Revise abs

Use offset Revise blank

Dilution

Half dilution **max. dilute times**

Diluent dilution

Figure 5-77

After resetting reaction plates, each parameter setup are as follows:

▲ Basic parameters

Control Board Address: address code for control motor, all motors only one.

Starting speed: 244 or 245.

Running speed: 247 or 248.

The first probe position for cleaning arm: show the opposition of the reaction cup corresponding the cleaning-probe.

The last probe position for cleaning arm: cleaning block with corresponding the reaction cup.

Position of adding sample: for adding sample.

Position of adding reagent: for adding reagent 1.

Position of adding reagent 2: for adding reagent 2.

Position of Mixing 1: for mixing 1 and a reagent.

Position of Mixing 2: for mixing reagent 2.

Colorimetric optical path: effective thickness of the light through the cuvettes.

Test period: complete sample and test cycle, changes incubation time properly.

▲ Test options

Absorbance amendment: after contrasting with standard absorbance, discrepancy can be corrected with it.

Offset amendment: places a black cup at the position of 80 and 90, for deducting the offset value during testing.

Blank amendment: water blank can be deducted each cycle during testing, after adding water, the water blank can be measured.

5.10.5.3 Sample plate

Setting of sample parameters, as shown in Figure 5-78:

The screenshot shows the 'Instrument run parameter' window with the 'Sample plate' tab selected. The interface is organized into several sections:

- Motor parameter:** Control Board address (21), Motor start speed (245), Motor run speed (248).
- Other:** Liquid volume Alarm (0), Correct Cup Position (1), Lable direction (radio buttons for Clockwis and Anti-Cloc).
- Position:** Out sample position (0), Step between out (72), Sample Number (50).
- Inner Pos.:** In sample position (0), Step between inner (0), Sample Number (0).
- Same plate 2 arm Parameter:** 2 arm sample position (3), Ise outer sample pos. (0), Ise inner sample pos. (0), Sample position (0), Sample position (1), ISE position (0).
- Scanner setup:** Outer Cup No. (0), Outer Cup adjust (0), Scan time (0), Inner cup No. (0), Inner Cup adjust (0).

Figure 5-78

▲ Motor

Address for sample-control panel: address code for control motor.

Starting speed: 245-248.

Running speed: 248-250; with reagent motor.

▲ Position of outer ring:

Position for the outer ring of sampling: for testing settings and pick and roll is correct or not.

Samples number: the cup number of outer ring of samples-lap.

Outer ring paces: paces between the neighboring cups.

DS-161: sample set of 50 samples, the outer ring paces 72, and no inner circle.

Pace is that the steps of adjacent cup by motor, such as outer ring step of samples is 72, each take a cup, the electrical take 72 paces and calculation of pace: $400 \times 9 / \text{Cup median} = \text{paces}$;

Inner Ring position

▲ Settings are the same with the "outer ring position."

▲ Parameter for a plate with double arms

The equipment has not the function.

▲ Other

Level alarm threshold: the minimum of remaining samples security paces, below this value to alarm for lacking of sample.

Cup-amendment: the original position of the 1st sample cup, which can be amended.

Label directions: the orientation of samples position

5.10.5.4 Reagent plate

Set parameters for reagent plate, as shown in Figure 5-79:

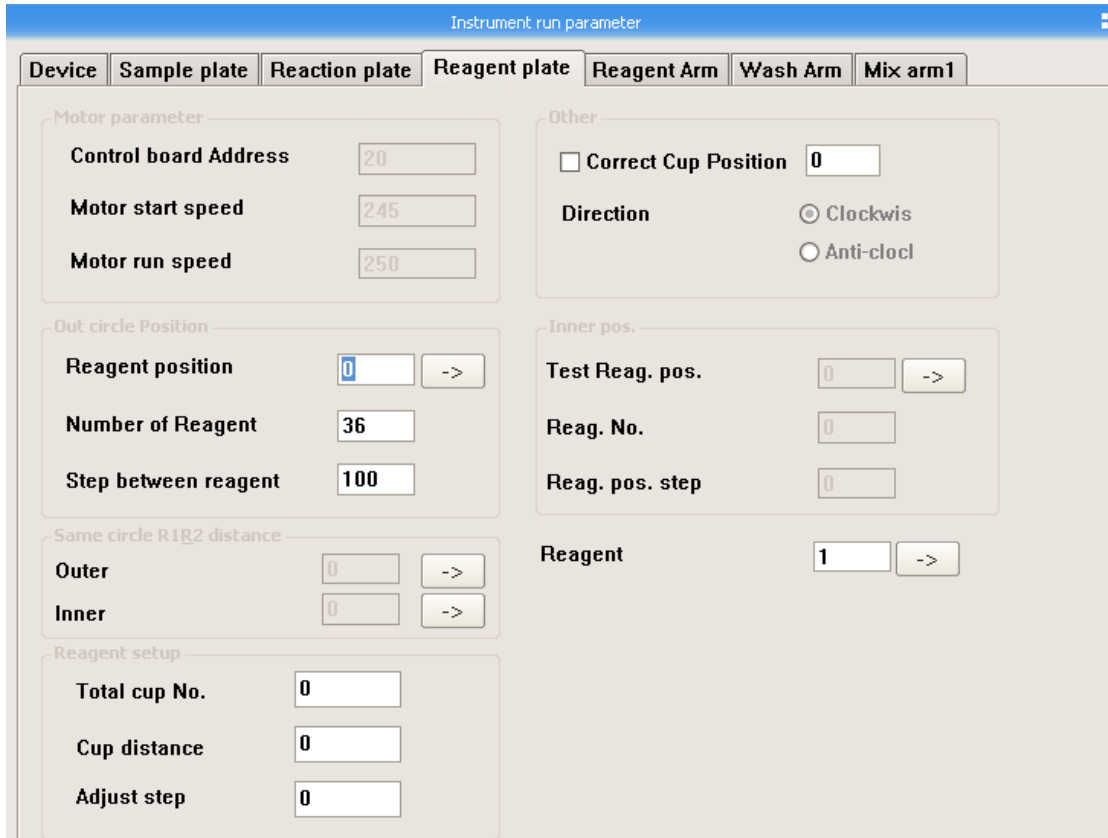

Figure 5-79

Setting of reagent plate parameters are the same as samples.

Interval for the same plate R1, R2: (The equipment has not the function.)



: When scanning, can be used for revising the reagent position and the scan head.

5.10.5.5 Reagent arm

The parameters of reagent arm shown in Figure 5-80 as following:

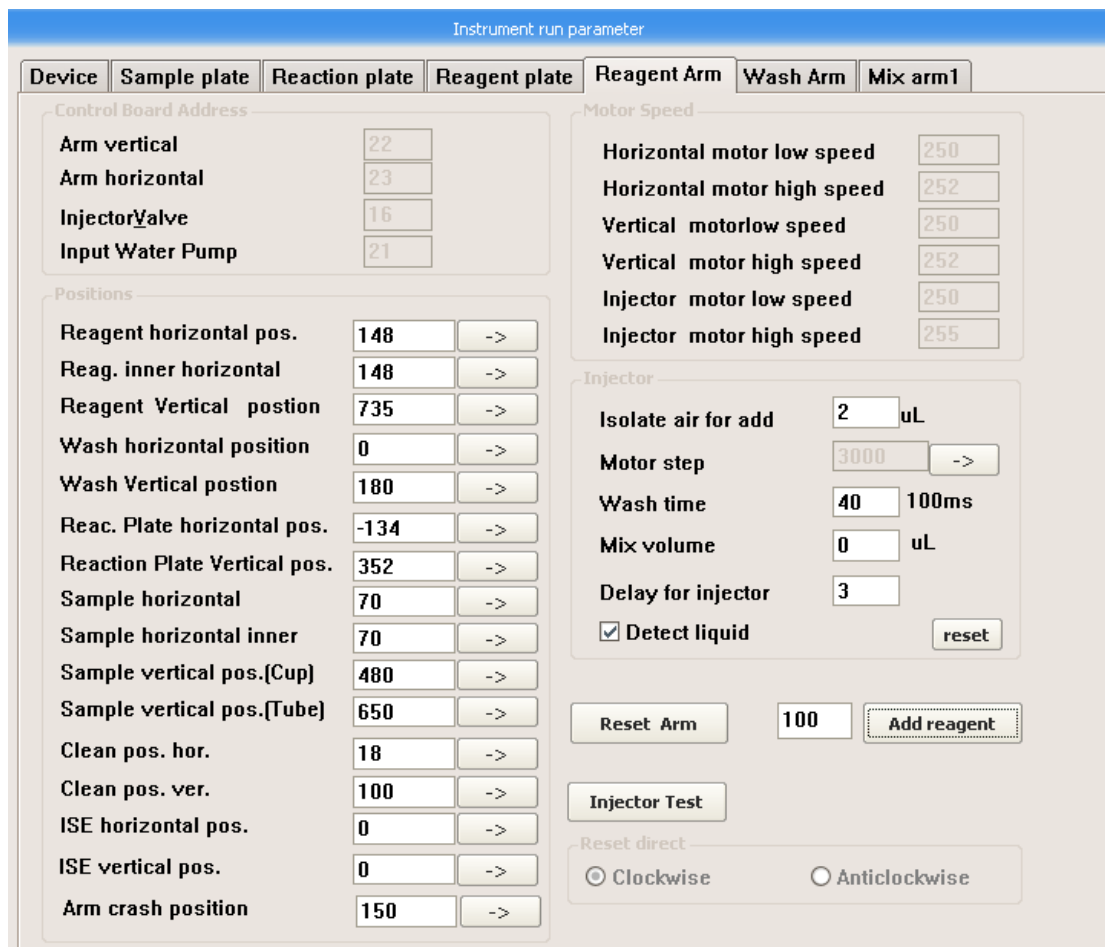

Figure 5-80

Horizontal position: horizontal paces for probe movement;

Vertical position: maximum vertical paces for probe movement;

Electrical control board and parameters setting of motors are as the same as sample plate;

Horizontal starting speed: 249 or 250;

Horizontal running speed: 251, 252, 253, if the speed of sample probe is too fast, can be set to 251;

Vertical motor speed and injector motor speed please do not modify;

▲ Injector

Sample air isolation: 5 - 30;

500UL motor steps: 3000, in accordance with volume of injector

Pump time: generally 20-40ms, can be extended on quest, while test cycle is needed to be prolonged;

Mix volume: injector mixing volume generally set to 100-150;

Syringe-like suction delay: generally set 3-10.

5.10.5.6 Wash arm

Setting of wash arm parameters, as shown in Figure 5-81:

The screenshot shows the 'Instrument run parameter' window with the 'Wash Arm' tab selected. The 'Control board address' section includes: Horizontal Motor (31), Input water valve (31), Input water pump (21), Waste pump (20), Air valve (checked, 22), Detergent Injector value (41), and Detergent pump (0). The 'Motor speed' section includes: Low speed (250), High speed (253), Injector start low (250), and Injector run high speed (255). The 'Injector' section includes: motor step (3000), Volume (50 uL), Value reset (0), and Injector delay (1). The 'Position_time' section includes: Wash Vertical (444), Wash input water (4 100ms), Add Detergent Time (0 100ms), and Wash output time (15 100ms). Buttons for 'Affusion', 'Empty', and 'Reset Arm' are also visible.

Figure 5-81

▲ Control board address

Arm lift motors: 31 for all address codes

Input water valve: 21 for all address codes.

Input water pump: 19 for all address codes.

Waste water pump: 20 for all address codes.

Bubble release valve: 26 for all address codes.

▲ Position and time

Vertical-wash position: wash arm drops to the depth of reaction cup.

Affusion time: filling time for reaction cup generally 5-15.ms

Time for pumping waste water: pumping time for reaction cup, generally 20-30 ms.

5.10.5.7 Mixing arm

Setting of mixing arm parameters, as shown in Figure 5-82:

Figure 5-82

Settings of control board, motor speed, position of machinery is as the same as above.

▲ Mix motor

Mix time: generally 10-20 ms.

Wash time: 10-20 ms.

Warning

- Address codes for motors, valves, pumps are prohibited to be changed.
- Test positions for sample arm, the reagent arm, mixing arm, must follow first horizontal, then vertical, the last reset. Otherwise, probes easy to be damaged.

5.11 Help

5.11.1 Help

Shows help information after clicking.

5.11.2 Important information

Explain computer configuration and installation, details as follows:

1. Computer configuration:

CPU: P4, the motherboard: Asustek, Gigabyte Intel 865 or above, and have a stable COM mouth, more than 1G memory, 52-speed drive, more than 64M AGP, run normally, built-in modem 56K.

2. Copy all the folders and files to hard disk.

3. Select all the folders and files; view their attribute, read-only attribute of the document will be removed.

4. If the open interface for the English menu, please select "Chinese" option in "View" menu under the "Language".

5. Login:

Checker: admin

Password: admin

6. The authorization process when it is installed:

1) Require the field-work, apply for authorization, 2) Send authorization to e-mail box of after-sales service company service@sinnowa.com. 3) Send the authorized documents to users. 4) The software dog can also be used directly, and be inserted into the computer USB port. 5) The authorized documents for users, it must be safety and copy into the same folder easy to look for and load.

5.11.3 About ABA

Introduction of the software version, please see Figure 5-83:

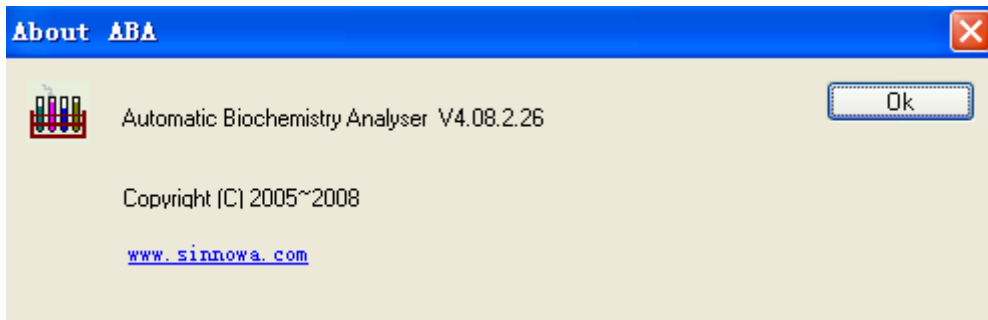

Figure 5-83

5.11.4 Apply license

Attention

- After being installed software to obtain authorization documents, and then use it after loading.

A method for applying authorization is as follows:

1. Operating software, the original checker and password is "Admin".
2. Run authorization in the help column and generate an authorization documents, such as DS1610708002, named followed the machine number as much as possible, as shown in Figure 5-84:

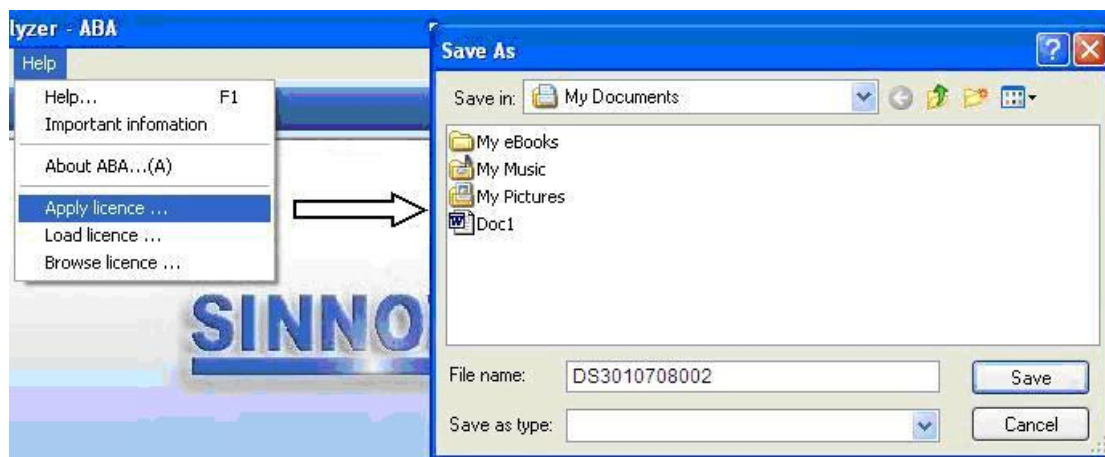

Figure 5-84

3. DS1610708002 authorization documents is sent to E-mail service@sinnowa.com the Company, and then authorized by the Company and have the formation of authorization DS3200708002-1, and then send the compressed document which is decompressed and loaded.

Another method of applying authorization

Use the software dog is authorized by the Company; insert it into the computer USB Interfaces, as shown in Figure 5-85:



software dog

Figure 5-85

Attention

- Software dog is only as a temporary use, hardware easily lost, must use the authorization documents.

5.11.5 Load license

Execute "load license", such as D3207080012-1 (decompression), this software can be used, as shown in Figure 5-86:

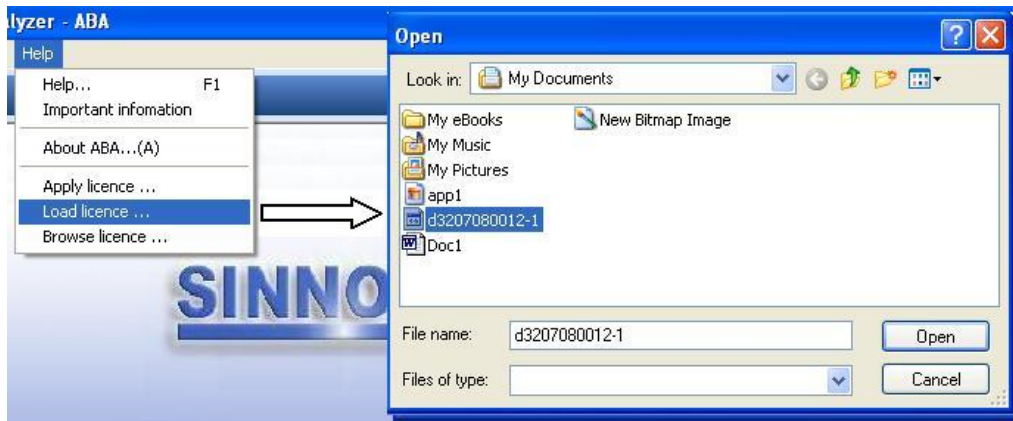

Figure 5-86

5.11.6 Browse license

Users can also view their authorization valid, as shown in Figure 5-87:

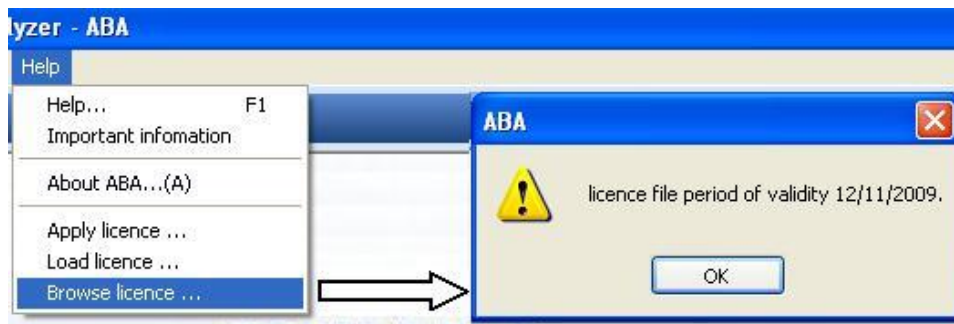

Figure 5-87

Attention

- Without authorization or expired can not operate equipment.
- Authorization should pay attention to decompress before use.

Chapter 6 REGULATION OF ROUTINE OPERATION

6.1 Turn the analyzer on

Turn on the power and preheat for 30 minutes before operation.

Attention

- Ensure the distilled water barrel has enough water and the distilled water barrel is empty before operating.
- Check the waste liquid tube and distilled water tube are blended or not to ensure its connection well before operating.
- Check whether power plug of the analyzer is connected to power outlet safely before operating.

6.2 Routine maintenance

Enter into “Device maintenance” item, then click “Wash pipeline” four times after clicking “Device reset” item and click “Wash probe” item four times. Click “Wash all cuvettes” item at last.

Users can also use “a key maintenance” to accomplish above operations.

Attention

- Ensure each probe is in its origin position before clicking “Device reset” item.
- Check whether cuvettes are placed well and the surface of the cups are smoothly and level before routine maintenance.
- Please wash the cuvettes before using, because the cuvettes are injected with water yesterday. If water is injected again, overflow distilled water will cause damage to the equipment..
- The routine maintenance before testing is to wash reaction cups and adding probes

to improve accuracy of testing result.

- Wash pipelines and probes before testing is to get rid of bubbles in the tubes to avoid water from spraying and the inaccuracy of adding sample.

6.3 Blank test

Enter into the “Device maintenance” item, which is a menu of the “Device run” to click “Wash pipeline” three times and then enter “Blank test” item to click the “Affusion” item and click “Test” item three times and store them. Set the number of the discrepancy of cup selections as 0.025. If the absorbency of each cup blank selected is not more than 0.025, it means the analyzer is in good condition and can run normally. Or otherwise, it needs to be washed for testing again. Pump water directly or clean finally. Of course this value is between 0.025 and 0.035 that can be used, but it isn't perfect.

Attention

- After testing cuvettes water blank three times, the change rate of absorbency for reaction cups should be not more than 0.025. Otherwise, clean and test them again.
- It is necessary to pump water after testing cuvettes water blank value; otherwise the test will be affected.
- The purpose of choice is to filtrate unqualified cups with not good light transmission. Please use the same group for good light transmission.
- During the filtration, the ones are more than 0.002 may be cleaned and tested again or changed directly.
- Clean outside of cuvette at every month

6.4 Add sample, control and standard

Click “Add sample” in the menu with “Task” and some information for patients can input at the same time. Besides, “add calibration” and “control” are also available.

Attention

- Make sure that the reagent, quality control, calibration are canonical and in period of validity.
- Control is used to check whether the result is normal and monitor its running to make the test results accuracy.
- Calibration sample is used to adjust the analyzer to make sure its test results accuracy.
- It is important to choose serum cup or cuvettes in container item. Or else, sample probes may be destroyed. For example, cuvettes are chosen, but containers are placed in the serum cup.
- Ensure reagent, water, control and calibration samples are ready before adding.
- Don't put reagent or water on the table board of analyzer for avoiding liquid from leaking into the analyzer.
- Clean reagent containers every week to avoid crystal.

6.5 Test

Enter into "Device run" menu firstly, open "Device maintenance" item and choose "Wash probe" to clean the probe three times. Then, click "Start test" item.

Attention

- Feed emergency sample at any time during the test.
- Samples with absorbency and reaction curve are not unusual should be retested instantly.
- Pay attention to reagent volumes at any time during test. Observe yellow alarm for supplementing it timely.
- The analyzer is used for clinic diagnostics, results for reference only.



Warning

- It is dangerous to touch reagents result in damaging to skin. When it happens, clean it as soon as possible.
- Because patients' serum samples perhaps have some potential biological risk, please don't touch them directly.
- Probes perhaps carry on serum sample, quality control sample, or calibration sample. Therefore, it's necessary to avoid hands from touching the probes because of its biological risk.

6.6 Print the test result

Enter into "Browse result" menu, choose "Sample result" item and then click "Print" item.

Attention

- The items that are not tested by the analyzer can be input in directly.
- If items are to be calculated, click the "Calculate item" firstly, then print them.
- Once the test results are amended, click the "Calculate item" again.

6.7 Routine maintenance

Enter into "Device run" in Navigation Bars and then choose "Device maintenance" item. Click "Device reset" firstly, click "Wash pipeline" item and "Wash probe" three times separately, and then click "Wash all cuvettes" item, finally, click "Affusion" item.

Above operations can be finished with "one key maintenance" function.

6.8 Turn off the analyzer

Collect and store reagents, quality control, calibration and sample well and turn off power

switch.

Attention

- Dispose the wasted sample and wasted liquid according to the regulations of the state and the local department.

Chapter 7 REAGENT, SAMPLE, DETERGENT, CONTROL AND CALIBRATION

7.1 Reagent

In order to get accuracy testing results, we suggest that you buy SINNOWA's biochemical reagents to match with the analyzers.

Attention

- Usage and storage refer to reagent introduction.
- Please read the reagent introduction to set related parameters. with the equipment item parameters
- Don't forget to reset biochemical item parameters when replacing reagents.
- Ensure the reagents are in valid period.
- After reagents are taken out from refrigerating box should be placed under the room temperature.
- Clean the reagent container every week to avoid from crystal.

7.2 Sample disposal

Vein blood 4 ml is collected with vacuum tube; after an hour, with speed 3000rpm do centrifugal processing to extract serum. If the sample is to be tested on that day, it can be kept it under room temperature, but if it is tested the other day, it needs to be cold storage. If it is kept over one day, the serum should be separated to be cold storage or freeze. The period of validity for samples is three days.

7.3 Detergent

Detergent is used for routine cleanness and maintenance .It is easy to clear the organic

stains in the tube and probes with detergent.

We provide some special detergent as follows:

H-AC high concentration acidic Detergent

AC low concentration acidic Detergent

H-AK high concentration alkalescent Detergent

AK low concentration alkalescent Detergent

NCL litmusless Detergent NCH high concentration Detergent

Above Detergent are used for probe maintenance, cup washing and washing for high pollution item.

Attention

- It takes about 5 to 10 minutes for probes, reaction cups and tubes to be dip into the detergent. Please wash them with distilled water.

Warning

- Comply with introductions for detergent container strictly and wear protective glasses and rubber gloves well. Once the detergent splashes to your skin, wash it as soon as possible, or see a doctor.

7.4 Control

Control sample is used to control the testing quality of analyzer to make testing result more accurate. It is suggested that the analyzer should be taken control test every day.

Attention

- Usage and storage for control samples please refer to introduction.
- Operator should reset parameters of the control item for those replaced control samples.

- Ensure reagents are in valid period.
- Suggest that you should establish management system of control.

7.5 Calibration

Calibration samples are used to calibrate the analyzer to get accurate test results. The analyzer needs to be calibrated under conditions as follows:

1. Install the analyzer firstly.
2. Replace reagents.
3. Beyond usual range for control result
4. The analyzer for being repaired.

Attention

- Ensure calibration samples are in valid period.
- If calibration samples are replaced, the operator should reset the biochemical item parameters.

Chapter 8 DEVICE MAINTENANCE

8.1 Daily maintenance

It needs to be maintained after testing every day. Steps are written as follows:

1. Enter into “Device/ device maintenance” item or “Device run/ device maintenance” navigation bar.
2. Click “Device reset”
3. Click “Wash pipeline” three times
4. Click “Wash probe” three times
5. Click “Probe maintenance” six times. Three times firstly with AC detergent and then three times with AK detergent.
6. Click “wash all cuvettes” three times.
7. Affusion water into cuvettes.

In order to make the equipment maintenance more convenient, the designer has set daily maintenance combination action. The first step is to enter into “Device / device maintenance” or “Device run/ device maintenance” navigation item and then choose items what you want.

Besides, it needs to be maintained under the conditions as follows:

- 1, Before testing every day;
- 2, After testing every day.



- Comply with Caution on the detergent container strictly and wear protective glasses and rubber gloves well. Once the detergent splashes to your skin, wash it as soon as possible. If it is serious, see a doctor if necessary.

8.2 Weekly maintenance

Weekly maintenance for the analyzer Steps as follows

1. Enter into “Device / device maintenance” or “Device run/ device maintenance” in the navigation bar
2. Place AC cleanser at reagent position 1. Click “soak cuvettes” and the analyzer begins to add it.
3. “soak cuvettes” for ten minutes and then click “Wash all the cuvettes” three times.
4. Place H-AC in reagent position 1 and click “Probe maintenance” four times. After this, replace the H-AC with H-AK, click “Probe maintenance” four times either. It is easy to clear the fibrin in the probes.
5. Take out cuvettes; clean cuvettes surface with rub-papers by hand. Do it carefully to avoid testing surface of cuvettes from damage.
6. Replace cuvettes and planish to ensure their surfaces are horizontal.
7. Clean probes and wash probes with alcohol tampons meanwhile ensure no batt is absorbed in the probepoint of probes and washing probes and don't drop into the reagents containers. Besides, not to remove, bend or destroy probes and washing probes.
8. Clean up reagent cases to avoid it from crystal.

Weekly maintenance under the conditions:

1. Considerable workload Everyday
2. Running after a week
3. Not being used for one week

8.3 Monthly maintenance

Monthly maintenance under the conditions:

1. Enter into “Device/ device maintenance” or. “Device run/ device maintenance” in the navigation bar
2. Put all the tubes into detergent with AK detergent which is produced by

SINNOWA.

3. Firstly wash the tubes several times and then make probes washed three times.
Ensure tubes and probes are marinated in the detergent.
4. Immerse all the intakes for five minutes; then put them into distilled water.
5. Click “Wash pipeline” five times and then click “Wash probe” five times
6. Take out the cuvettes; clean the surface of cuvettes with rub-papers by hand. Do it carefully to avoid the testing surface of cuvettes from damage.
7. Replace the cuvettes and planish them to ensure their surfaces are horizontal.
8. Clean the outside of cuvette
9. Operate the “Weekly maintenance” one time.

Attention

- If reaction cuvettes have been used for more than one month, clean surface to avoid dust from depositing.

8.4 Quarter- maintenance

Quarter-maintenance is necessary for the analyzer. Steps are written as follows:

Clear stains on their surface firstly; feed **lubricating oil** on add sample arm, reagent arm, wash arm and guide stem of dilutor. It is worth noticing that the smear is easy to diffuse.

As a result of its diffusion to sensor, it leads motor reposition out of control.

Check whether the piston of dilutor leak or not and clean the tip of piston with alcohol tampon. Besides, it is necessary to smear grease in the half of piston to avoid leakage and airproof syringe

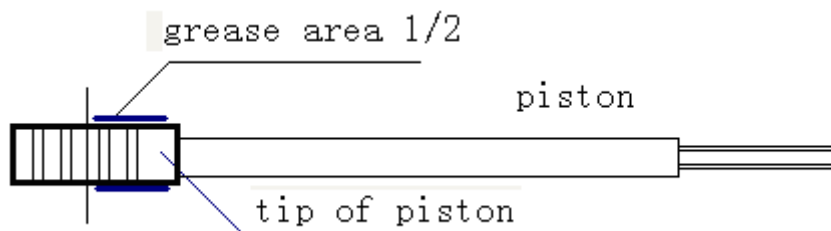

Figure 8-1

Chapter 9 TROUBLESHOOTING

This chapter introduces all kinds of malfunctions for routine operations, and analyzes some related reasons and solutions for malfunctions.

Warning

- Turn off the analyzer and cut off power supply firstly for maintenance. If the analyzer is running, maintenance is dangerous for the analyzer and the operator. Therefore, the work must be taken by professional maintenance men.
- Matching power supply and voltage for the analyzer. Or else, SINNOWA is not responsible for it

Caution

- To analyze samples under malfunctions, maybe some correct results can not be got. If the malfunctions exist for during analyzing samples, please solve them and then analyze samples.

Attention

- This manual is not part of the maintenance booklet and only a reference for the operator to dispose malfunctions.



- Sample, control samples, calibration samples, wasted liquid and so on have potential biochemistry risk. Therefore, the operator must comply with the regulations for safe operation to wear personal guard such us: gloves, protective clothing.

9.1 Malfunction phenomenon and maintenance

Please take measures to eliminate malfunctions when the analyzer is running or not, If

malfunctions are in Chart 9-1 still exist, please contact with the after service department or local franchisers of SINNOWA as soon as possible. We are pleasure to serve you.

Chart 9-1

Malfunctions phenomenon	Possible reasons	Disposal steps
1. The analyzer doesn't work when the power is on(the indicator light is off)	<ol style="list-style-type: none"> 1. The power cable is disconnection. 2. Main program is not started up. 3. Fuse is broken. 4.The alternating current socket has no power. 	<ol style="list-style-type: none"> 1. Examine the connection whether is in good condition. 2.Turn off the analyzer and restart the analyzer after 5 minutes 3. Examine the fuse. 4. Examine the socket whether has power. <p>If malfunctions still exist, please contact with the after service of SINNOWA or local service departments as soon as possible.</p>
2. The liquid leaks from analyzer	<ol style="list-style-type: none"> 1. The tube is damaged. 2. Connections break off. 3.Dilutor syringe leak 4.3-way valve is jammed. 5.The pump leaks water 6. The bulb-release case leaks water. 	<p>Turn off the power firstly; wipe the liquid leaked away , then examine whether the connections break off, the tube is undamaged and the pump & the air bubble release case exist leakage, and check 3-way valve is jammed</p> <p>If malfunctions still exist, please contact with the after service of SINNOWA or local service department as soon as possible.</p>
3. The connection between the	<ol style="list-style-type: none"> 1. The analyzer hasn't chosen the right COM port, MAINCOM=O (COM1). 	<ol style="list-style-type: none"> 1.Reset the COM1 of the analyzer 2.Examine the RS232 cable 3.Reset the testing channel under the

<p>computer and the analyzer is failed (the indicator of power is on)</p>	<p>2.RS232 is not connected well or it's inside wires is connected well</p> <p>3. The setting of testing channel of the analyzer is wrong.</p> <p>4. The computer's COM is wrong.</p> <p>5.The signal line of motor' control breaks off。 (6 line)</p> <p>6.Main program is not started up and the mother board is something wrong。</p> <p>7.The parameter of“ Hardware” of the analyzer has missed</p> <p>8. The software runs two windows at the same time.</p> <p>9.12 channel is set wrongly in the setting of parameter of the hardware</p>	<p>item “ analyzer's running/device”</p> <p>4.Replace the COM of computer</p> <p>5.Examine the signal line of motor' control</p> <p>6.Turn off the analyzer and restart the analyzer after 5 minutes 。</p> <p>7.Copy the backup documents or use the function “the restore of the hardware parameter”</p> <p>8.Close one window of them , or restart computer</p> <p>9.Choose the appropriate channel according to the mother board</p> <p>If malfunctions still exist, please contact with the after service of SINNOWA or local service department as soon as possible.</p>
---	---	---

<p>4. Sample is not absorbed in.</p>	<ol style="list-style-type: none"> 1. Sample probe jammed 2. Dilutor syringe doesn't work 3. Dilutor syringe leaks water 4. The sample probe touches the bottom of cuvettes 5. There's something wrong with liquid level sensor so that the sample probe can't get into the cup 6. The tube is damaged and the connections break off. 7. Relevant magnetism valve is damage or out of work 	<ol style="list-style-type: none"> 1. Get it through by a thin probe and run "probe maintenance" 2. Examine the dilutor syringe and motor and check the setting of address code of the dilutor 3. Replace the piston of dilutor syringe 4. Adjust the height of probe 5. Get down the sensitivity of liquid level sensor and examine the connection, make sure the probe touches the surface of sample every time 6. Check the tube is broken and or connections break off. 7. Examine the electromagnetic valve by the motion testing program whose voltage is 24V. <p>If malfunctions still exist, please contact with the after service of SINNOWA or local service department as soon as possible.</p>
<p>5. The sample probe touches the bottom of cup or can't get into the cup</p>	<ol style="list-style-type: none"> 1. The line of liquid level sensor is broken or is not connected well. 2. The sensitivity is too high or low. 3. The parameter that the high of probe is wrong set. 4. The motor board is damaged 	<ol style="list-style-type: none"> 1. Check the line of liquid level sensor 2. Adjust the sensitivity of liquid level sensor (8-13) 3. Get down the position to make the distance between the reagent & sample probe and the bottom of reaction cuvettes as 3mm and the distance between sample probe and reaction cuvettes and the bottom of serum

	<p>5. Sample cuvettes can't check the bottom of the rack because of its electromagnetic valve.</p>	<p>cuvettes are both 3mm.</p> <p>4.Examine electromagnetic valve by the motion testing program</p> <p>5.Choose the eligible sample cup</p> <p>If malfunctions still exist, please contact with the after service or local service department of SINNOWA as soon as possible.</p>
<p>6. Water suspends in the tip of probe after cleaning.</p>	<p>1.Tube' damage or break make it leak air</p> <p>2. Reagent probe is jammed.</p> <p>3.Relevant electromagnetic valve</p> <p>4. Dilutor syringe exist leakage.</p> <p>5. Sample probe prick the bottom of the cuvettes.</p> <p>6. There exists bleb in tube.</p>	<p>1. Examine the tube.</p> <p>2.Get it through by a thin probe or run "probe maintenance"</p> <p>3.Examine electromagnetic valve by the motion testing program</p> <p>4. Replace the piston or glass tube of dilutor syringe.</p> <p>5. Adjust the position of sample probe and the sensitivity of liquid level sensor.</p> <p>6. Take "probe cleaning"5 times.</p> <p>If malfunctions still exist, please contact with the after service or local service department of SINNOWA as soon as possible.</p> <p>.</p>
<p>7. Cleaning probe of washer drops water</p>	<p>1. If the short probe drops water after cleaning, it indicates the one-way valve is not closed well.</p> <p>2. If the short probe drops water after cleaning, the</p>	<p>1. Take the tube away, clean and press it in the opposite direction with syringe to make it closed completely</p> <p>2. Adjust the down depth of cleaning block to make it touch the bottom properly.</p>

	<p>down depth of the probe is too deep to touch the bottom of the cuvettes.</p> <p>3. The cleaning longer probe drops water or the seven probes of cleaning device are not in level line so that they absorb water incompletely to cause leakage.</p> <p>4. When the analyzer's reposition or the probe cleaning is taken, the short probe drops water. It should be that 3-way electromagnetic valve is not closed well.</p> <p>5. Cleaning block is loose.</p> <p>6. Cleaning block is not in the middle</p>	<p>3. Adjust the long probes in level line and the cleaning block is 1mm lower than other long probe; test it by maximum motor step, the cleaning block can touch the bottom properly, but the other probe don't touch the bottom.</p> <p>4. Open electromagnetic valve and clean membrane.</p> <p>5. Fix the cleaning block with pastern.</p> <p>6. Adjust the vertical position of cleaning block and ensure cleaning block lie centre of cuvettes after adjusting the position of holder.</p> <p>If malfunctions still exist, please contact with the after service or local service department of SINNOWA as soon as possible</p>
<p>8. The testing results is not accurate</p>	<p>1. The reaction cuvettes is dirty</p> <p>2. The facula of optical path doesn't locate in the middle of cuvettes.</p> <p>3. The voltage of reaction cuvette is not in the usual range.</p> <p>4. The tube is damaged.</p>	<p>1. Replace the reaction cuvettes.</p> <p>2. Adjust the facula of fiber to make it lie in the middle and the distance between the facula and the bottom of reaction cuvette is 1.5—2mm。</p> <p>3. Adjust the value of signal and offset</p> <p>4. Examine the tube</p> <p>5. Replace the piston or glass tube and add grease</p>

	<p>5. The dilutor syringe exist leakage.</p> <p>6. The position and height of sample probe are unsuitable.</p> <p>7. Reagents and quality control sample are out of date.</p> <p>8. Electromagnetic valve is damaged</p> <p>9. The liquid level sensor is out of work.</p> <p>10. The setting of testing parameters is wrong</p> <p>11. The testing voltage and absorbency are unstable.</p> <p>12. Sample & reagent probes are jammed.</p> <p>13. Can not well control to the temperature of reaction plate.</p> <p>14. RS232 cable is loose.</p> <p>15. There's water left behind in the reaction cuvette because the reaction cuvette is unstable or the cleaning tip is not in the appropriate height.</p> <p>16. Encoding disk rubs the</p>	<p>6. Adjust the position and height of the sample probe.</p> <p>7. Replace the reagents and quality control sample.</p> <p>8. Examine the electromagnetic valve by the motion testing program.</p> <p>9. Adjust the sensitivity of liquid level detecting board</p> <p>10. check and reset the parameters</p> <p>11. Check whether connection to ground is well and voltage is stable and the testing board is loose or leak light. Examine whether the filter is damp and the sides of fiber is fixed well. Besides, the range of facula is $\Phi 2-\Phi 2.5$.</p> <p>12. Get it through by a probe and take "probe maintenance"</p> <p>13. Check or adjust control of the temperature of reaction plate</p> <p>14. Fix the RS232 cable</p> <p>15. Adjust the position of reaction cuvette and the height of cleaning tip to keep them level.</p> <p>16. Adjust the encoding disk to make it locate in the middle and clean the sensor with alcohol or blow, or replace it.</p> <p>17. Connect the testing cable again.</p> <p>18. Short pin 2,3 of no used channel</p>
--	--	--

	<p>sensor</p> <p>17. The testing cable isn't connected well.</p> <p>18 Not short pin2,3 of no used channel</p> <p>19. The sensor used for counting is loose.</p> <p>20.The water used for cleaning cuvette is not enough</p>	<p>19.fixed the counting sensor(short sensor)</p> <p>20. Extension of the time of water-in and make the capacity as a half of the cuvette.</p> <p>If malfunctions still exist, please contact with the after service or local service department of SINNOWA as soon as possible</p>
<p>9. The voltage is zero or rather lower when the cuvette water blank value is tested</p>	<p>1.The lamp is damaged</p> <p>2. The wire connected with lamp is loose.</p> <p>3. There' is something wrong with the voltage of power supply.</p> <p>4. There is something wrong with the cable connected with signal device</p> <p>5. There is something wrong with mother board</p> <p>6. The filter is damp</p> <p>7. RS232 connection is useless.</p>	<p>1. Replace the lamp</p> <p>2. Examine the connection of the lamp.</p> <p>3.Examine or change the power supply</p> <p>4.Examine the signal connection</p> <p>5. Replace the mother board</p> <p>6. Replace the filter</p> <p>7. Examine whether the RS232 connection is loose or change it.</p> <p>If malfunctions still exist, please contact with the after service or local service department of SINNOWA as soon as possible</p>
<p>10. The reagents and the water can't be absorbed</p>	<p>1. Sample & reagent probe is jammed.</p> <p>2. Leakage exists in Dilutor syringe.</p>	<p>1.Get it through by a probe and take "probe maintenance"</p> <p>Change the piston or glass tub</p> <p>3.Adjust the sensitivity of liquid level</p>

and distributed	<p>3, Liquid level detecting is useless.</p> <p>4. Relevant electromagnetic valve is damaged.</p> <p>5. The tube breaks off.</p>	<p>detecting board</p> <p>4.Examine electromagnetic valve by the motion testing program</p> <p>5. Examine the tube.</p> <p>If malfunctions still exist, please contact with the after service or local service department of SINNOWA as soon as possible</p>
11. The software is crashed when the operator modify the name of patients	<p>The option of the dialog box "the item "Name" of data-base is bank or not" is 'NO". It's limit to version V3.</p>	<p>Open the data-base and find out the SAMPLE_PATIENT_INFO and then design the database. Choose the option of the dialog box "the item "Name" of data-base is bank or not" as 'YES".</p> <p>If malfunctions still exist, please contact with the after service or local service department of SINNOWA as soon as possible</p>
12. The analyzer doesn't test the items inputted	<p>1. The information of the reagents is set integrally.</p> <p>2. The LASTID of data-base is less than the ID sequence generated automatically by the patients at present.</p> <p>3. There are some blank characters in the information of the reagents.(It's limit to version V3)</p>	<p>1. Set integral information about the reagents.</p> <p>2. Amend the LASTID of data-base as the ID of the last patient pluses one.</p> <p>3. Open the REAGENT_INFO of Biochemistry and delete the items without names.</p> <p>If malfunctions still exist, please contact with the after service or local service department of SINNOWA as soon as possible</p>
13. The setting	<p>The character of document</p>	<p>Get rid of the "read-only" of "Hardware"</p>

<p>of machine parameter can't be saved.</p>	<p>"Hardware" is read only.</p>	<p>If malfunctions still exist, please contact with the after service or local service department of SINNOWA as soon as possible</p>
<p>14. All red hints are on when the cuvette water blank value testing is being done.</p>	<p>The item "blankVotage" of "Hardware" hasn't been set.</p>	<p>Set the item "blankVotage" by the sequence below: "blankODFilter=0.025 blankVotageMax=62000 blankVotageMin=30000" If malfunctions still exist, please contact with the after service or local service department of SINNOWA as soon as possible</p>
<p>15. The blue and the red hints appear when the cuvette water blank value testing is being done.</p>	<p>1. The red hints indicate its voltage is beyond the usual range 30000—62000. The blue hints indicate exceeds the range of the blank absorbency and the discrepancies among cuvettes is large.</p>	<p>1, If the voltage is lower than 30000, it means the reaction cuvettes should be changed. If the voltage is higher than 62000.it means the detecting voltage needs adjusting.</p>
<p>16. The absorbency is wrong.</p>	<p>1. The setting of wavelength is wrong. 2. There are disorderly characters in the "cup blank" file, which affects the results of wavelengths.</p>	<p>1. Choose the right wavelength over again. 2. Open the "cup blank" files and delete the content. Repeat test the "cuvette blank" and saved it. If malfunctions still exist, please contact with the after service or local service</p>

		department of SINNOWA as soon as possible
17. The information about the patients is the same such as name	1. The No. of diagnosis or register of patients are the same.	1. Amend the No. of diagnosis or register of patients to make them different. If malfunctions still exist, please contact with the after service or local service department of SINNOWA as soon as possible
18. The computer or the software system has crashed.	1. The computer's configuration is some poor condition or its running is unstable. 2. Windows is unstable or not reliable. 3. The system has been attacked by virus. 4. The switch about interfaces is too fast. 5. Configuration files has been damaged or missed.	1. Replace a high-configuration computer. matching with the software 2. Reinstall. the system 3. Antivirus computer 4. Don't switch the interface too fast. 5. Copy or use the backup documents
19. The items testing have not been done.	1. The parameter of reagent position hasn't been set. 2. Data base has happened errors.	1. Set the parameter of reagent position 2. Backup the data base "ABAD.MDB" and delete the relevant information as follow : If malfunctions still exist, please contact with the after service or local service department of SINNOWA as soon as possible

The data needs to be deleted in the data base “ABAD.MDB”: and backup ABAD.MDB before it is deleted

SAMPLE_ITEM_INPUT_RESULT

SAMPLE_ITEM_PRINT_RESULT

SAMPLE_ITEM_TEST_RESULT

SAMPLE_ITEM_TEST_TASK

SAMPLE_MAIN

SAMPLE_PATIENT_INFO

SAMPLE_REGISTER_INFO

 **Warning**

- You must backup the data base in advance because once the data is deleted; it will never be able to recover.

 **Caution**

- If you delete or amend any document of this software, do backup for the whole items in advance to inquiry or restore.

Solutions for being jammed sample & reagent probes:

Open “action test”. First of all, click “water pump on”; secondly, choose “valve on” and then click “valve off”. Test several times. So, the conclusion will show samples & reagent probe is jammed or not. Besides, we can judge conditions about the 2-way electromagnetic valve or by syringe dispense water. And get it through by a probe and take “probe maintenance” or “probe cleaning”.

The way to discern whether the 3-way electromagnetic valve is well:

Solutions for improper the 3-way electromagnetic valve:

Method 1: Find out relevant dilutor syringe in the “action test” and turn on and off electromagnetic valve come-and-go to notice sound. which means electromagnetic valve is well. Or else, it’s damaged.

Method 2: Carry on “Device maintenance/wash pipeline” to observe whether there is water in the cuvettes. If there is water, electromagnetic valve is in good condition. Or else, it’s not.

Solutions for the stability of detecting system:

Mix ALB and TP in 1:10 and then remove sample probes. (for accurate testing results). With TP testing method to observe its repeatability. If CV is less than 0.65%, it means the detecting system is stable.

Generally speaking, if the testing results are not normal, it is caused by the detecting system or sample which can be judged in this way.

9.2 Corrections and replacements for common parts of the analyzer

In order to make the analyzer run normally, it’s necessary to correct or replace some parts for effective maintenance.

Attention

- The user must be trained by professional engineers who carry on maintenance and replacements.

9.2.1 The replacement to lamp

Being damaged or running for 2 years.

The steps as follows:

- 1, Turn off analyzer for 15 minutes
- 2, Open the back cover of the analyzer; find power adapter of lamp and cut it off.
- 3, Unscrew four screws on the cover of lamp and remove the cover and then remove the chinaware housing for the lamp.
- 4, Unscrew four screws fixing the lamp and remove the damaged lamp.
- 5, Connect the chinaware housing of the lamp again and fix the lamp with the screw. And ensure the shrapnel is in the right direction.
- 6, Fix the cover with four screws.
- 7, Connect the power adapter of lamp.
- 8, Close the back cover.

 **Warning**

- Do not turn off the power supply before replacing the lamp. Or else, it may damage the lamp again.
- It is dangerous to take replacement when the analyzer shut down just now. Because, the temperature is very high.

9.2.2 The replacement for the piston of injector

The steps as follows:

The steps as follows:

- 1, Enter into “Device run/ device maintenance”, and then click “Device reset”.
 - 2, Open the window of the injector.
 - 3, Unscrew the tail screw of injector’s piston.
 - 4, Unscrew the screw for fixing the glass of syringe and then remove the glass and the piston.
 - 5, Take out the old piston from the glass and clean the new piston with alcohol.
- Smear the grease at the middle of the piston and insert the piston into the glass carefully and ensure that the piston reach the top of the glass.

6, Adjust and fix carefully with screw. Ensure the piston plumbs down to the center of the glass. As the figure 9-1, 9-2 show.

7, Draw the piston down about 3mm along the glass gently

8, Screw the screws lying in the two ends of piston tightly.

9, Close the window of dilutor syringe well with screw.



Figure 9-1

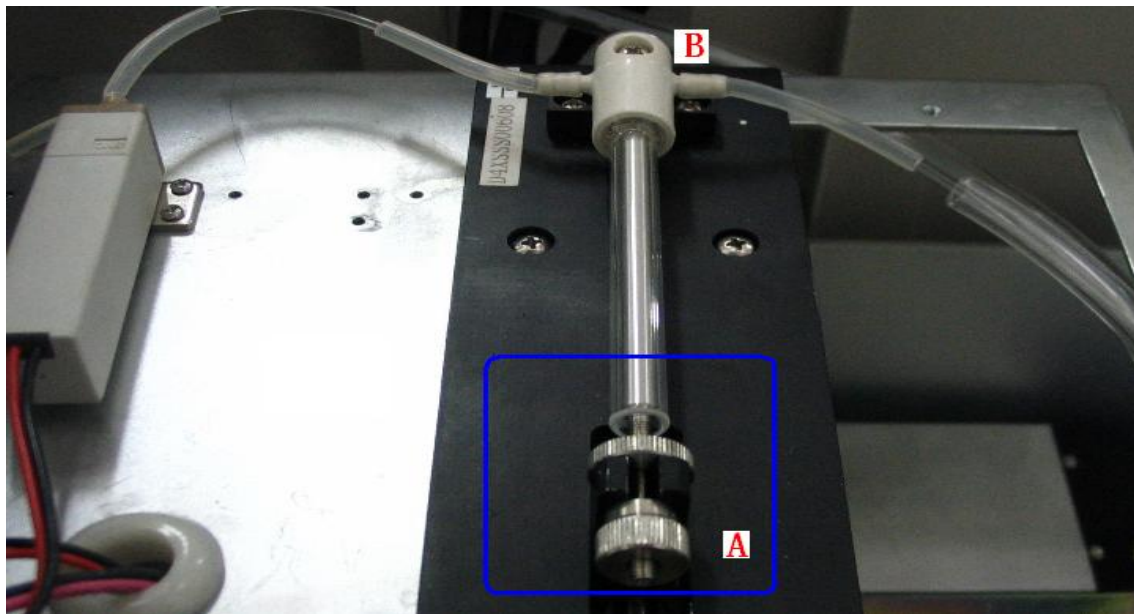

Figure 9-2

Attention

- Do not scratch the piston during installation. Or else, it is easy to make the piston leak air so that testing results are not accurate.
- Ensure the piston is situated in the center of the glass. Or else, it may damage the glass or reduce lifespan of the piston.

- While the piston has been used for three months, it must be smeared grease.

9.2.3 The replacement to probes

The method of replace samples probe is the same as the regent probe's replacement.

Concrete steps as follows:

- 1, First of all, opens the cover of the probe and then cut off swathe for fixing the probe with pliers.
- 2, Unscrew the pinching screws with fixing wire and the compacting screw of the probe.
- 3, Remove the probe and the soft tube covered the probe.
- 4, Install a new probe and a soft tube. The structure of the soft tube is as the below figure 9-3 shows.
- 5, Fix the probe and the wire well with the compacting screw and swathe
- 6, Close the cover.

As the below Figure 9-4 shows:

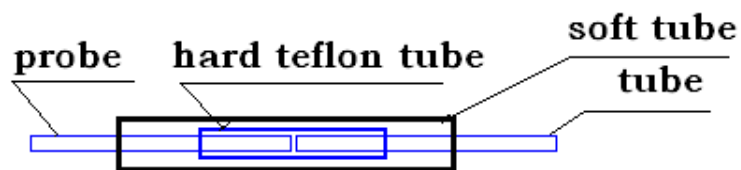

Figure 9-3

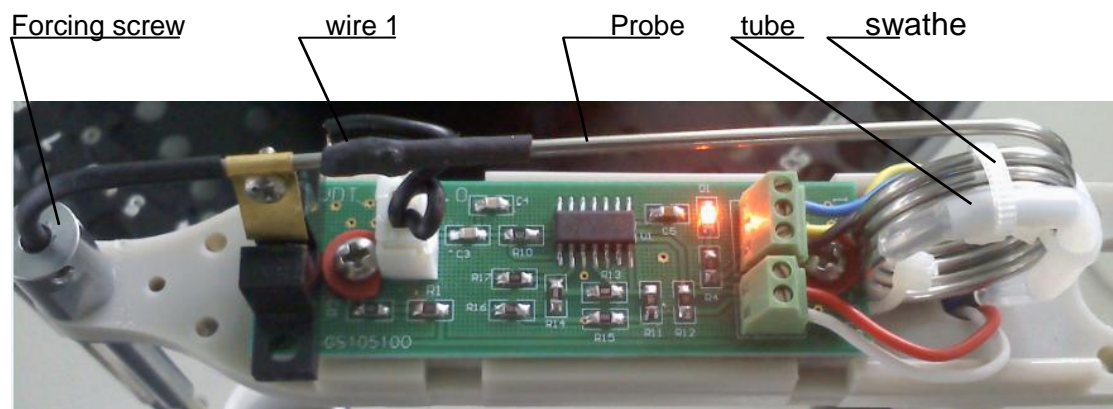

Figure 9-4

Attention

- Ensure the installed probe is vertical.

The screw (M2*4) fixing the connecting line 1 of probe is not too long. Or else, the probe would be pressed so that the probe can't flex up and down result in crashworthiness is out of function

9.2.4 The replacement to cuvettes

While the cuvette has been smirched or damaged, it needs to take the testing "cuvette water blank test". If the blank absorbency of the cuvette exceeds 0.02A and still useless after it has been cleaned, we suggest that replace it.

Attention

- The anterior side and the back side are both detecting interface. Therefore, do not touch the two sides.
- The surface of the cuvettes placed must be level. Or else, it is easy to leave behind the water in the cuvettes during the cleaning so that the testing results are not accurate.
- Use the same batch cuvettes as far as possible.

9.2.5 The replacements to fuse

Steps are as follows:

1. Take the fuse out from the appendixes bag. To mention that the fuse of mainframe is 8A and water heating system is 4A.
2. Turn off the power of analyzer and pull out the plug.
3. Pull the power wire from the power socket of mainframe and elicit the fuse housing.
4. Take out the damaged fuse housing and install a new fuse into fuse housing and then plug the fuse housing into power socket.
5. Switch on the power plug.

Caution

- The operator must use fuse of appointed specification. Do not misuse the two fuses.

9.2.6 Adjustments for GAIN & OFFSET

Take the 12-channel main board for example. The picture of main board is as the figure 9-5 shows:

12- Channel main board

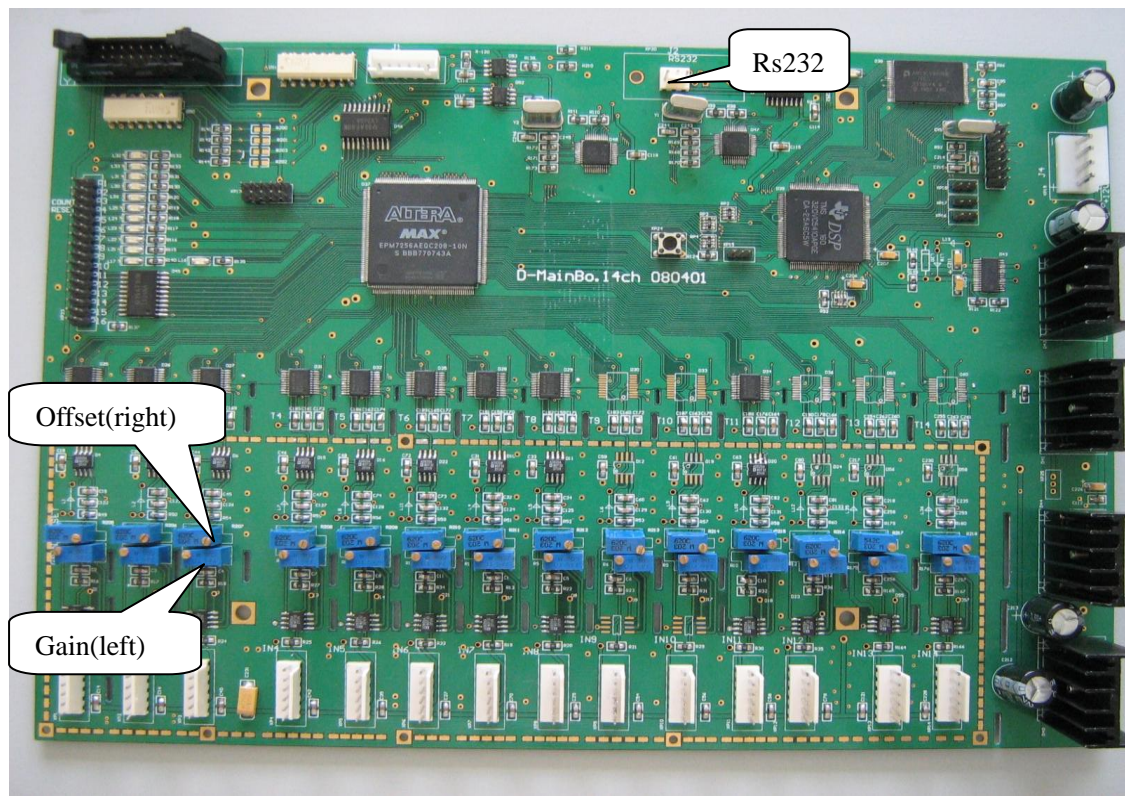

Figure 9-5

Seen from the figure 9-5, lists every part and relevant function of the mother board in detail. The 6-core socket on the left is used to connect the detecting board. The initial voltage of detecting board can be measured and amplified AD through the resistance on the right. Thus, it can be judged whether the detecting board and its initial voltage are in normal range. 340nm: voltage 0.2-0.4, 405nm: voltage 0.4-0.8 and so on. In the two-row resistor, the left arrangement is the adjustment to the GAIN and the right arrangement is to adjust

the OFFSET. The detecting channels from up to down are: 340、 405、 450、 505、 546、 578、 620、 670nm etc.. If individual is different, perhaps the order is different. So, consider as bought analyzer as standard.

9.2.6.1 The adjustment to OFFSET

Enter into “Blank test” interface of the software after analyzer is reset. As the Figure 9-6 shows: choose “Monitoring” and take out the cuvettes where each wavelength lies. (The installation of the instrument may have different,) and then put them into the black cups which are used for sheltering light. As the Figure 9-6 shows, observe the real-time voltage and adjust the resistor of every channel of the right arrange to the numerical value needed. If the numerical value varies greatly and exceeds 80, it needs adjusting.

Relevant adjustments:

- 1, Examine capability of detecting board and check whether it is fixed well and installed suitably.
- 2, Examine the connecting wire or replace.
- 3, Replace the main board.

Generally speaking, the reaction curve is not desired and the absorbency of reagent is unusual (more than 2.2) or repeatability is not good, it is necessary to check the OFFSET numerical value.

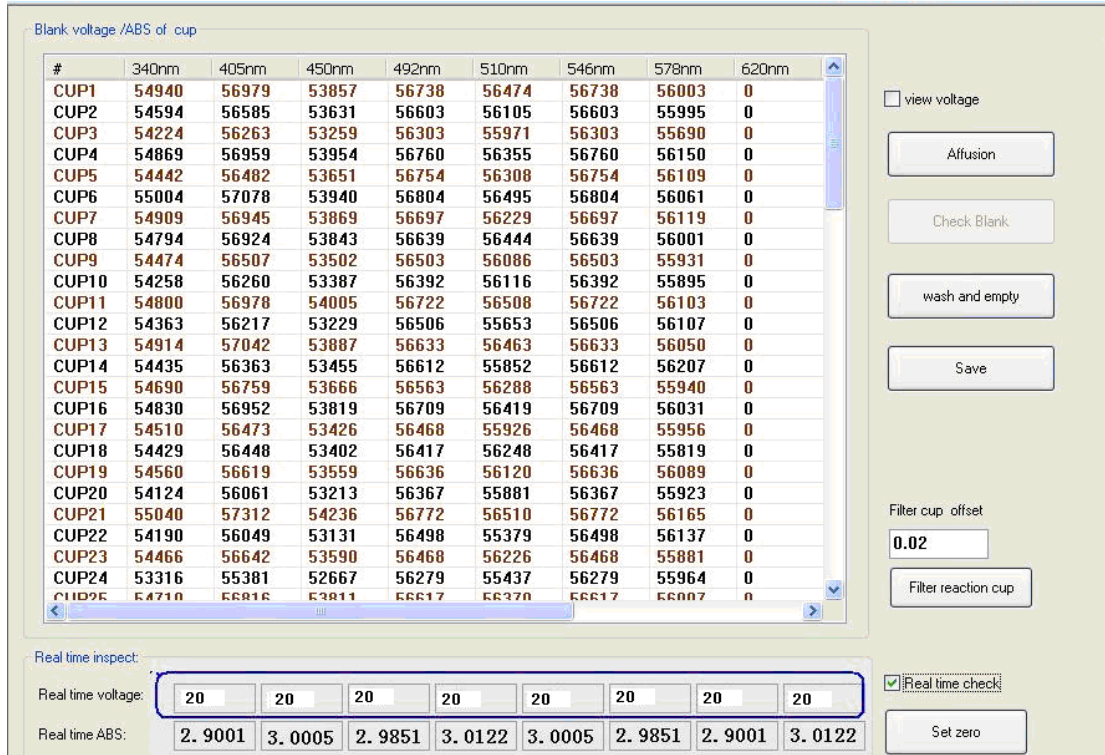

Figure 9-6

The steps of the adjustment to OFFSET, please refer to Figure 9-7

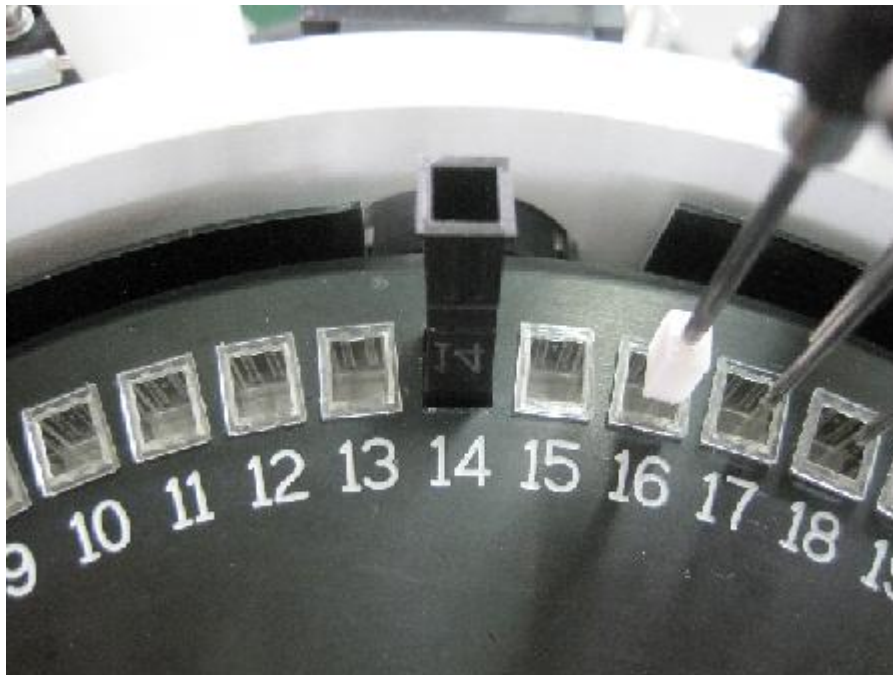

Figure 9-7

The adjustment to OFFSET:

- 1, Take out the cuvettes;
- 2, Pull it into the black cuvettes for sheltering the light;
- 3, Adjust the resistor every channel on the right of the main board It is suggested that OFFSET should be examined every 3 months. The normal range: 0-40.

9.2.6.2 The adjustment to GAIN

Please refer to above the adjustment. After injecting water into cuvettes, observe real time voltage and adjust resistor of every channel to reach necessary value 55000 and usual value is 30000~62000. As the below figure 9-8 shows: (it needn't the black cuvettes for sheltering the light).

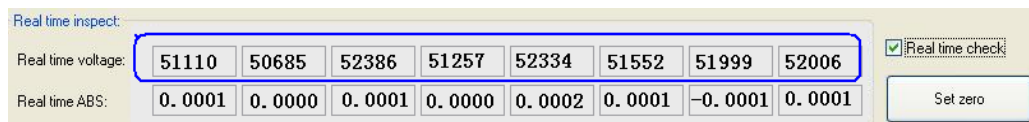

Figure 9-8

Chapter 10 TRANSPORTATION AND STORAGE

10.1 Transportation

Transportation should be in accordance with contract, keep away from toxic, harmful, and corrosive substances

Prevent from severe shocks, rain and exposure and overturned during transportation.

10.2 Storage

It should be stored in well-ventilated, dry environment after being packed; no storing with toxic, harmful, corrosive materials and prevents from raining.

Appendix 1: Manual scanner installation and application

F1.1 Installation

Steps are as follows:

1. Connect scanner to serial port COM3 or COM4 of the computer
2. Use "Admin" to login and open s "Device \ device parameter \ device..." password is "999", the interface appear as shown in Figure F1-1:

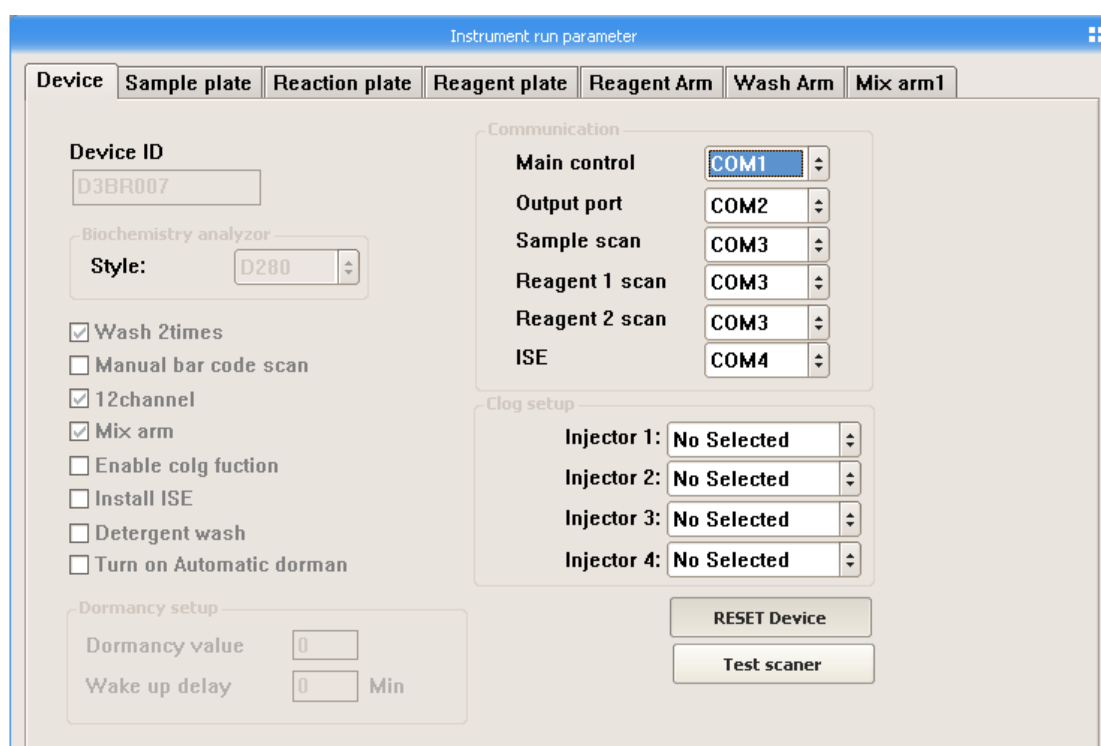

Figure F1-1

3. Sample scanner serial port is set as scanner switch-in serial port.
4. Following interface hints scanner self -testing will be shown in fihure F1-2.

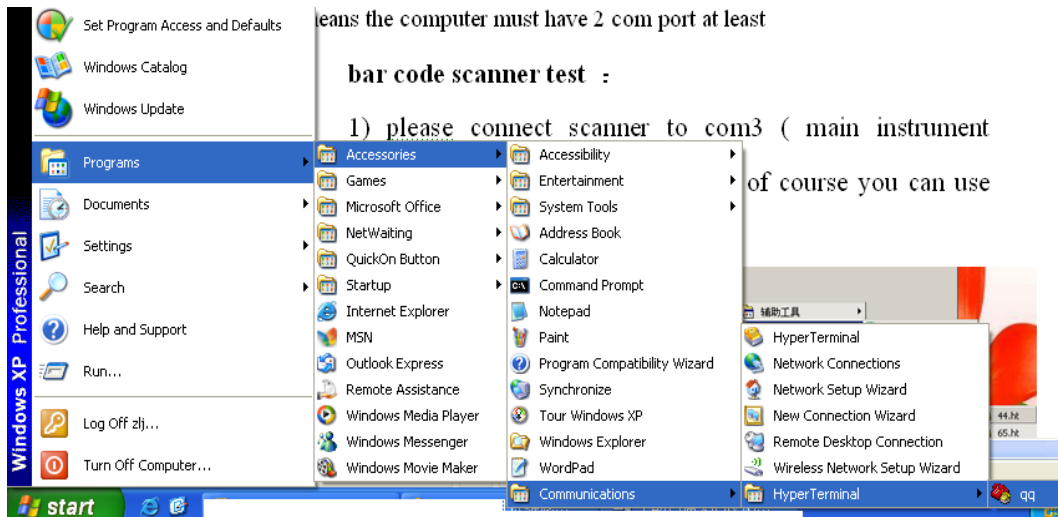

Figure F1-2

Click "44.ht" to show as Figure F1-3

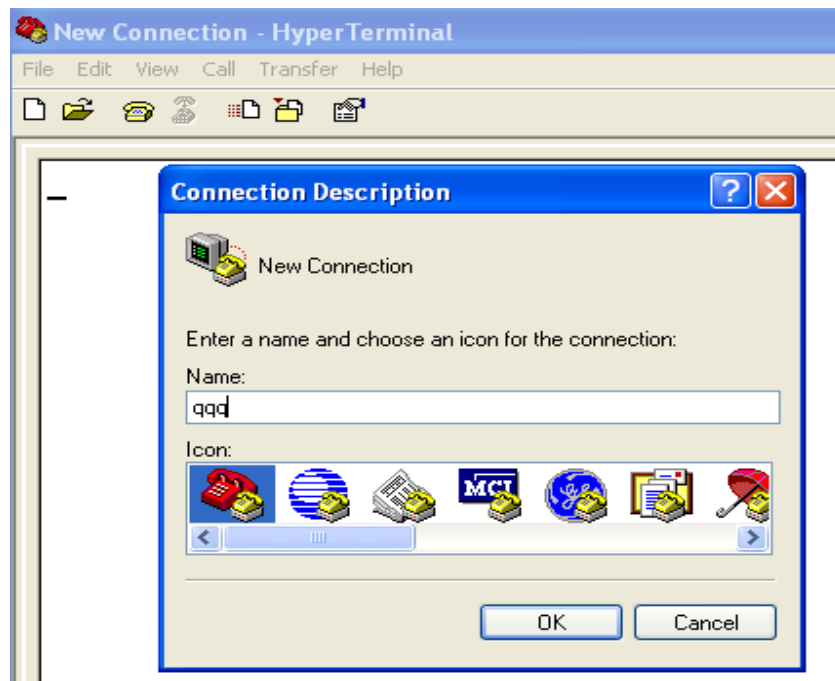

Figure F1-3

For example, input name: qqq, and then press "OK", shown as Figure F1-4

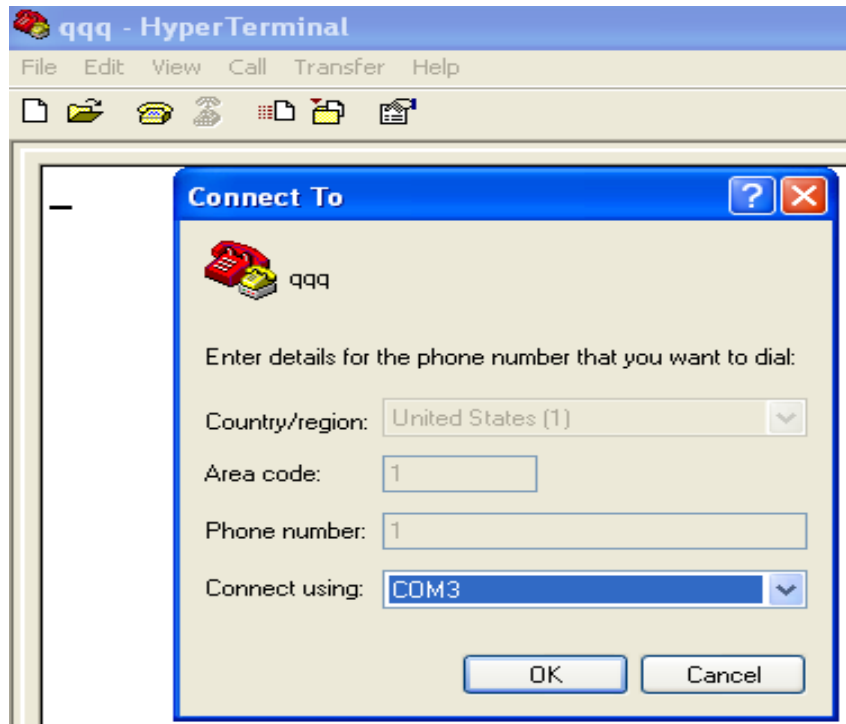

Figure F1-4

If the scanner is connected to serial port of the computer, and click drop-down list to select COM3, and then click “OK” for showing the attribute interface for COM3, please refer to Figure F2-5.

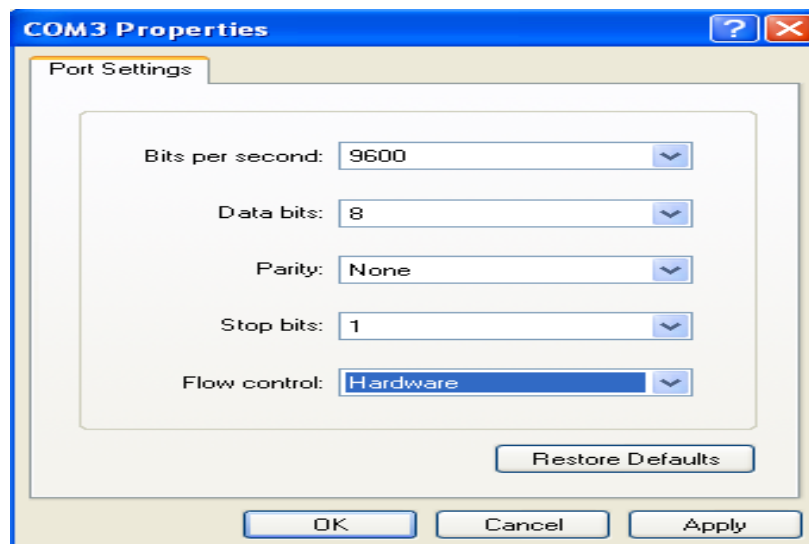

Figure F1-5

Please set COM3 port, click “OK” finally and finish the canner automatic test.

Newline methods of the scanner see Figure F1-6.

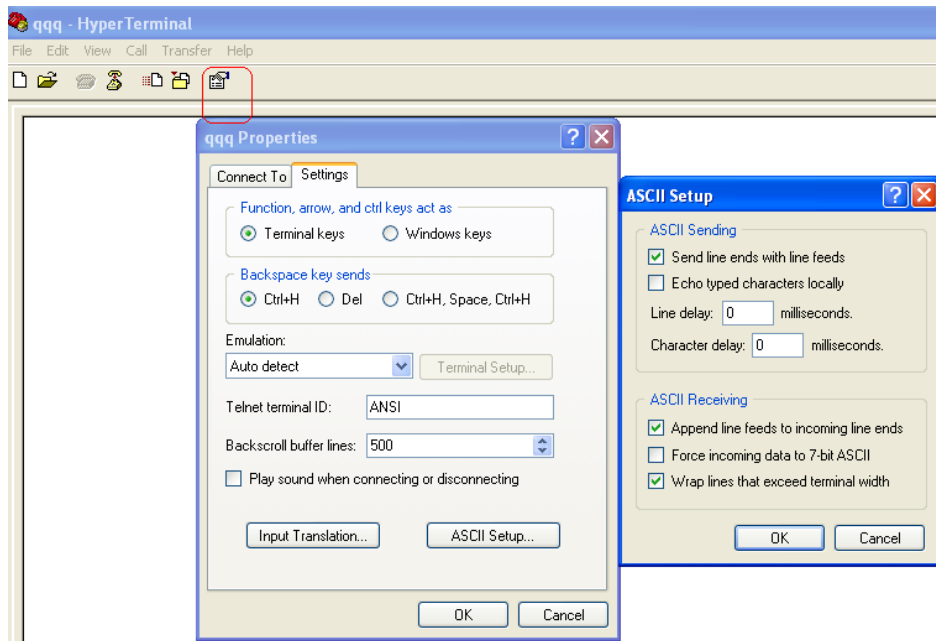

Figure F1-6

F1.2 Manual scanner application

1. Reagents setup.

Enter software: 'item' 'reagent setup', input reagent position number, and scan bar code of reagent container, as shown in Figure F1-7

Item	R1 Bar Code	R1 Pos	R1 All Volume	R1 Height	R1 Alm Gate	R1 Left times	R2 bar Code	R2
ALT	69204599	3	35000	75	8	0	2005	0
AST	69204523	7	30000	35	5	0	2006	9
TP	69001573	1	35000	75	5	0	2004	1
ALP	1007	6	30000	35	5	0	2007	8
ALB	9787105	2	35000	75	5	0	9787117052733	2
CRE	6924782	4	35000	75	5	0	2014	5
GLU	1011	7	30000	75	5	0	2011	3
TBILL	6541	8	3000	35	8	0	2006	16
BUN	1015	8	32000	35	5	182	2015	10
ALB1	24658	5	3000	35	8	0	1254	0
CHD	1012	6	30000	35	5	0	2012	6
r_GT	1009	7	30000	35	5	69	2009	7
TG	1010	8	30000	35	5	182	2010	8

Figure F1-7

Select the item, and then use scanner to scan bar code, then input reagent position, reagent total volume, reagent height, the warning valves of reagent ect.

2. Add samples

According to steps "detection task\add sample" or "task\add sample" into add sample window, shown as Figure F1-8:

Sample ID

Patient ID: -> Name: -> Sex: Age:

Barcode input

Bar code scan Cup correction Single scan

Manual scanning Scanning... Don't change interface

Other task

Run1 Run2

Sample information

Sample ID: Sample Style:

Dilution ratio: Cup position: Container:

Send Date: Number of items:

Preset Batch: Emergency

ALTS FIERL TRIG
 UREAS MGL UA
 ALT LDL HDL
 urea TBIL MG
 ALP TBILL GLU
 TP DBILL CHO
 ALB AST CA
 CRE UREE
 DBIL GGT

Batch add

Batch add

Use same cup

Enable Add Sample

Uncheck

Use

Input sample task:
 single Add:1.Add Sample; 2.Select item;3.OK
 Batch add:1.Add sample;2.Select item;3.Select Batch;4.OK.

Figure F1-8

Use scanner to scan the bar code of the patient, the registration numbers of the patient are bar code. Simultaneity it is input by hands to add samples.

3. Statistic reagent volumes

After adding items, with steps "Check\Statistic reagent" and into the window of Statistic reagent, see Figure F1-9.

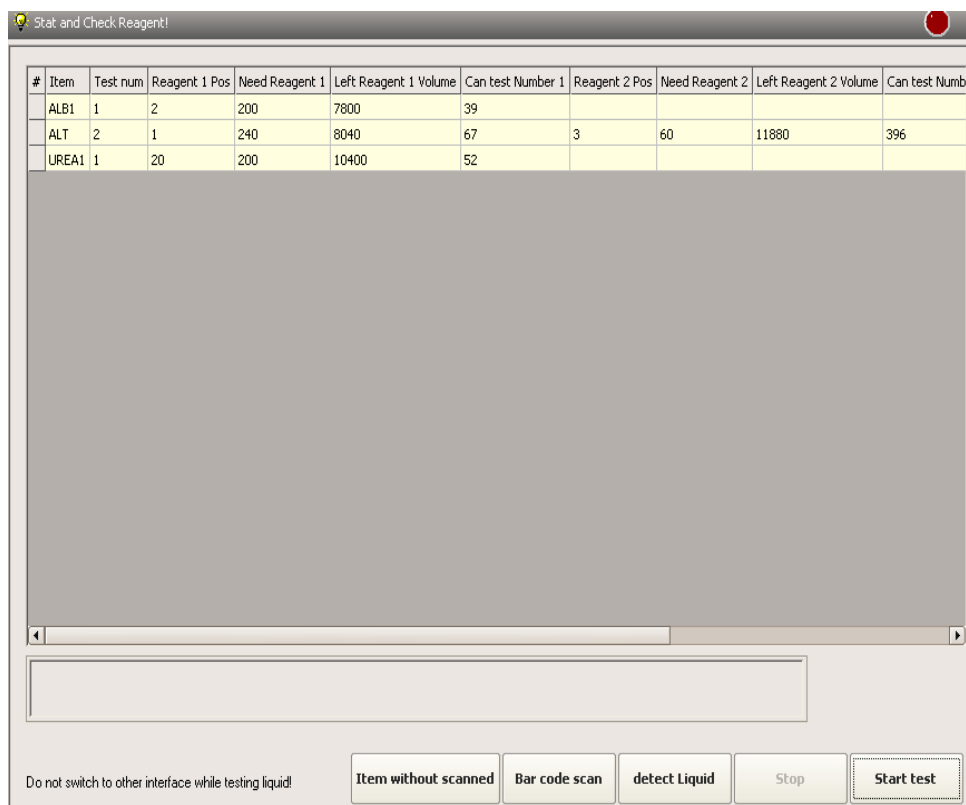

Figure F1-9

Click “Bar scan” to scan the reagent which is needed to be detected.

F1-3 Built-in scanning setup

F1-3.1 Serial port setup

See the introduction of "F1.1 manual scanner installation".

F1-3.2 The sample plate and the reagents plate setup

The gap of the cup position is between cup No. 1 and scan head, and can remedy scan head center by slight adjustment steps, as shown in figure F1-10 and F1-11.

Instrument run parameter

Motor parameter

Control board Address

Motor start speed

Motor run speed

Other

Correct Cup Position

Direction Clockwis
 Anti-clocl

Out circle Position

Reagent position

Number of Reagent

Step between reagent

Inner pos.

Test Reag. pos.

Reag. No.

Reag. pos. step

Same circle R1R2 distance

Outer

Inner

Reagent

Reagent setup

Total cup No.

Cup distance

Adjust step

Figure F1-10

Instrument run parameter

Device Sample plate Reaction plate Reagent plate Reagent Arm Wash Arm Mix arm1

Motor parameter Control Board address: 21 Motor start speed: 245 Motor run speed: 248		Other Liquid volume Alarm: 0 <input type="checkbox"/> Correct Cup Position: 1 Lable direction: <input checked="" type="radio"/> Clockwis <input type="radio"/> Anti-Cloc	
Position Out sample position: 0 -> Step between out: 72 Sample Number: 50		Inner Pos. In sample position: 0 -> Step between inner: 0 Sample Number: 0	
Same plate 2 arm Parameter 2 arm sample position: 3 Ise outer sample pos.: 0 Ise inner sample pos.: 0		Sample position: 0 -> Sample position: 1 -> ISE position: 0 ->	
Scanner setup Outer Cup No.: 0 Outer Cup adjust: 0		Scan time: 0 Inner cup No.: 0 Inner Cup adjust: 0	

Figure F1-11

F1-4 Barcode read

F1-4.1 The barcode into the corresponding reagent position

Enter the password "999", as shown in figure F1-12:

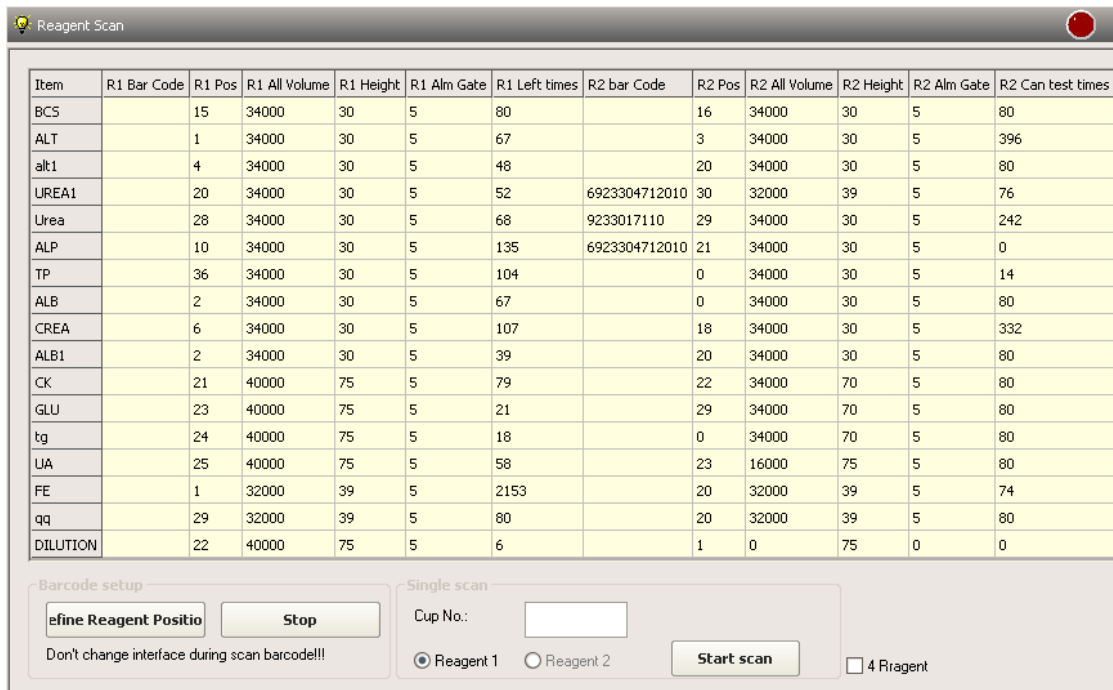

Figure F1-12

According to the reagent position of the manual entry to define barcode

All scanning:

- 1 instrument reset
- 2 scanning 1-36, automatic save the reagents barcode of the reagent position
- 3 instrument reset

Single step scanning:

- 1 instrument reset
- 2 choose reagent plate, fill out the reagent position of the corresponding barcode
- 3 for the single step scanning, automatic save reagents barcode

View scan results: change reagent barcode, scanning again.

F1-4.2 Sample scan

As shown in figure F1-13:

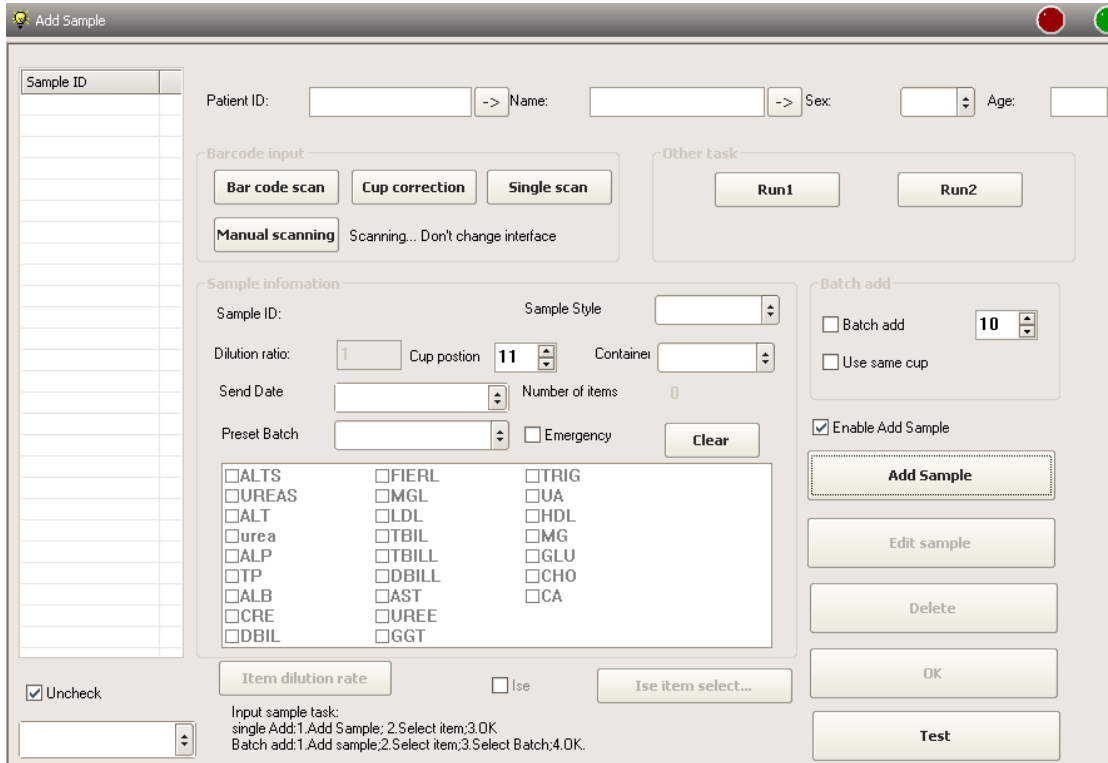

Figure F1-13

All scanning

1. instrument reset
2. all scanning 1-50

If the database don't have the corresponding barcode, it should add new ID and corresponding cup number; if it has, it should modify cup number according to the barcode.

Part of the scanning can choose any sample cup number, as shown in figure F1-14:

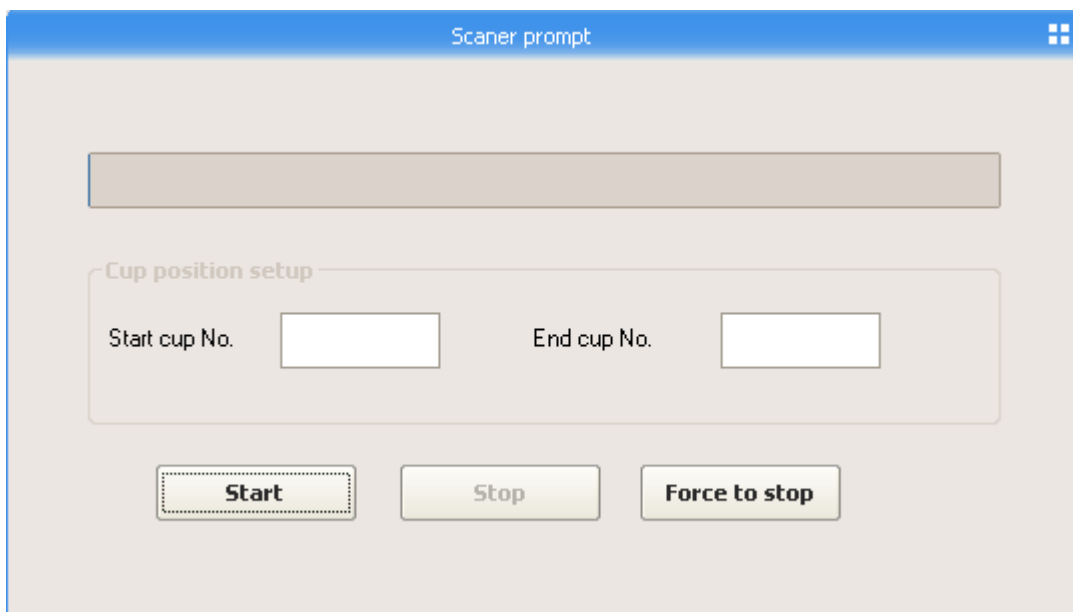

Figure F1-14

3. instrument reset

Single step scanning

1 choose the sample ID, and store barcode according to the sample cup position.

F1-5 Start measuring

When measuring, the sample scan button is shielding.

Start measuring, check the reagent position according to the reagent setup of the barcode; click "barcode scanning", the system automatically scans reagent 1 and reagent 2; and reset the barcode corresponding reagent position, as shown in figure F1-15:

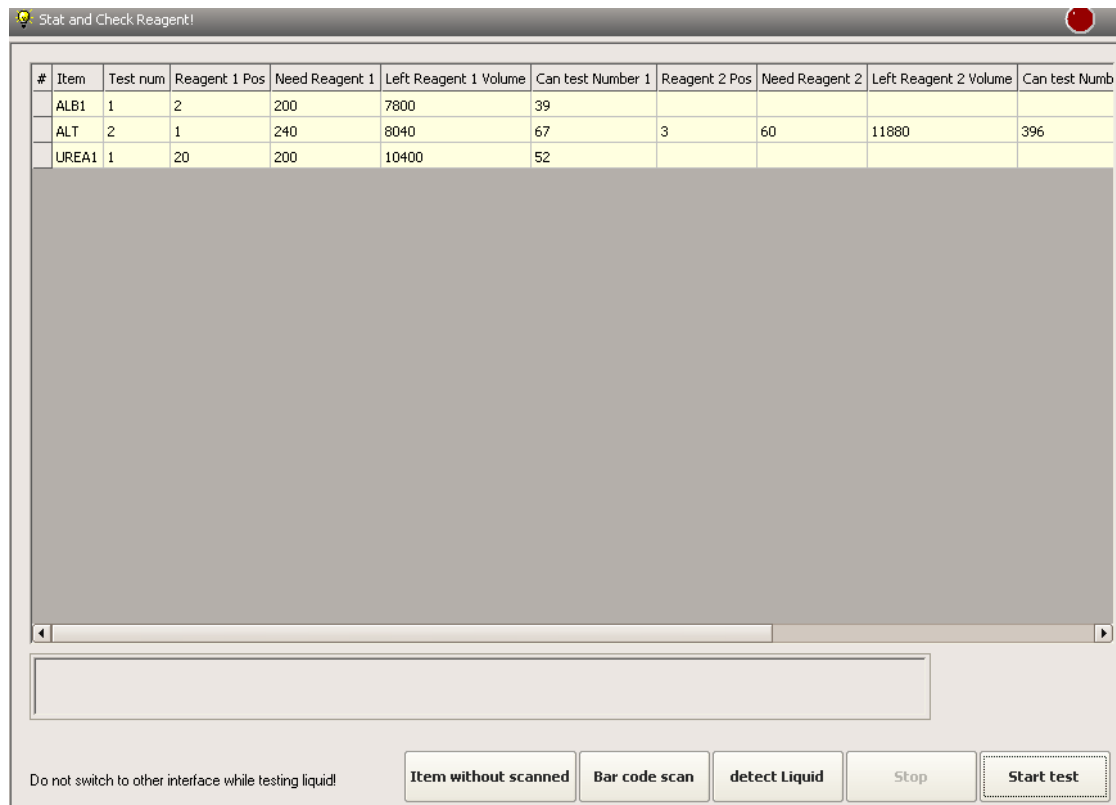
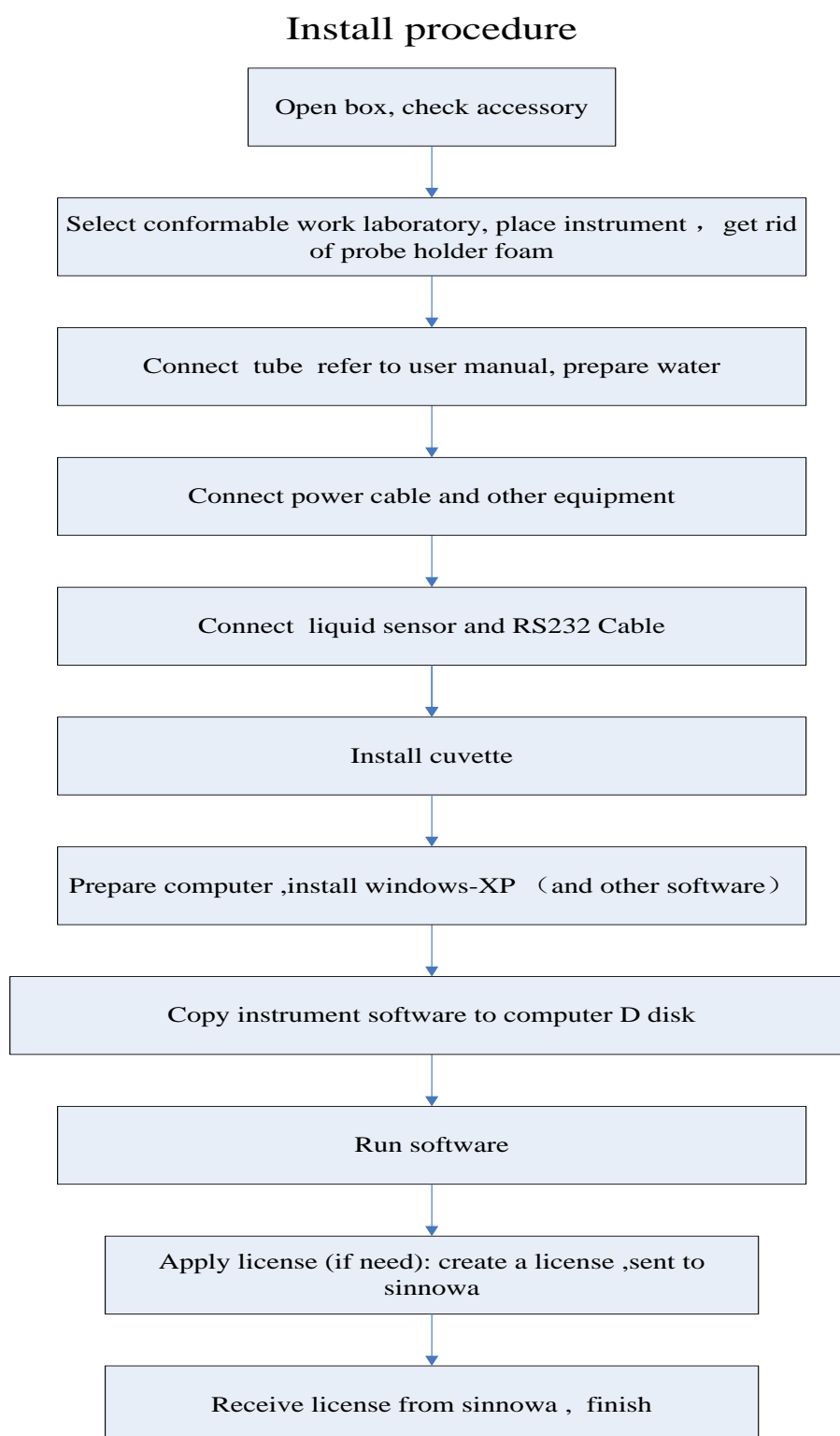

Figure F1-15

After scanning, automatically activate to the reagent information without scan; the projects are all scanning in the reagent 1 and reagent 2 which are not shown; if it don't show the barcode, and it can manually enter the reagent position.

Appendix 2 The process of installation



Appendix 3 The process of installation

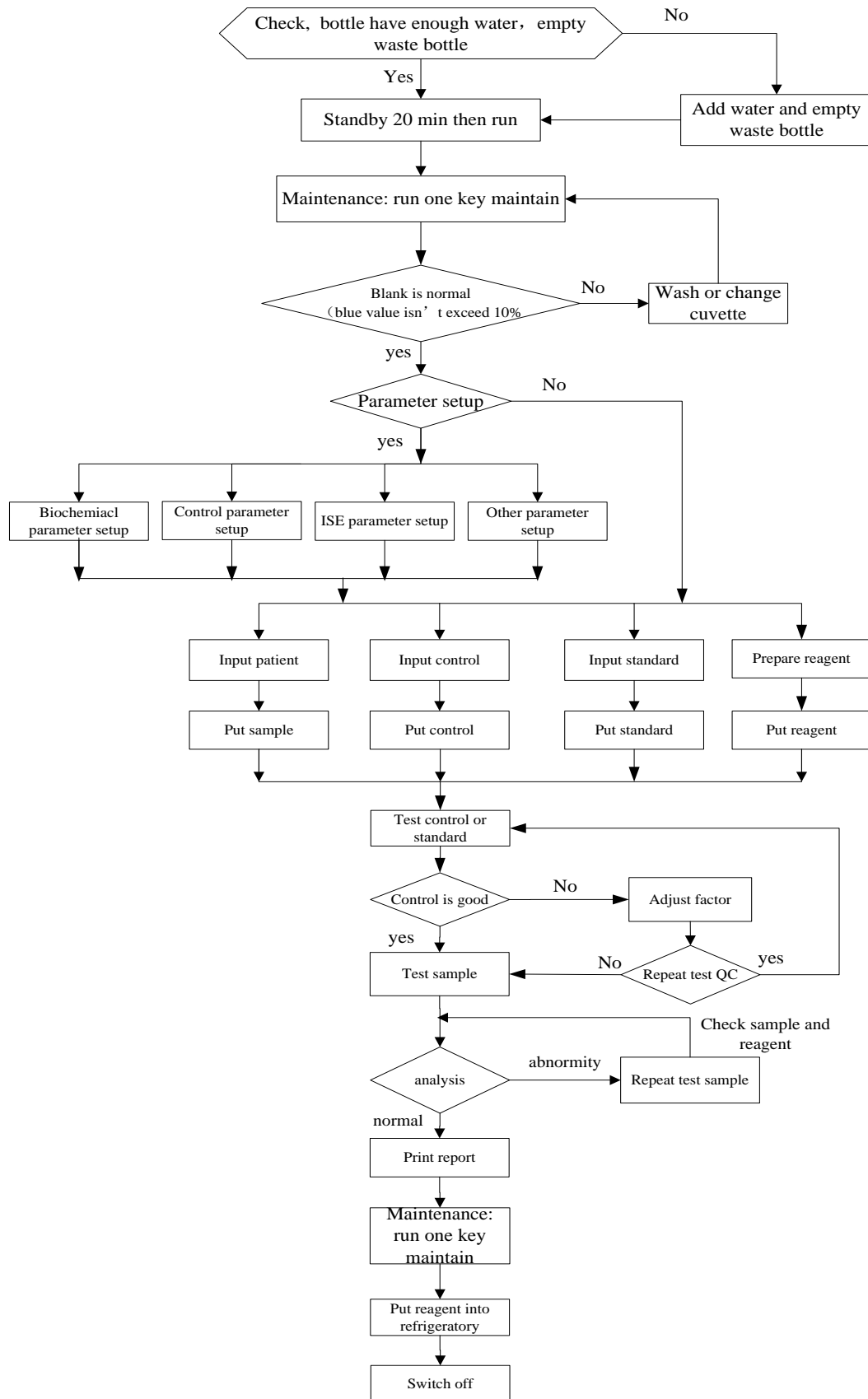

Appendix 4 Component List

In order to ensure that the instrument can normal work and get good reliable test results, the following the components of the instrument are supplied by our company.

No.	Items	No.	Items
1	Lamp	20	Fuse
2	Synchronous belt	21	Power Switch (ON/OFF)
3	Sensor	22	Power Switch (I/O)
4	Stepper motor	23	Temperature control board
5	Wash arm contain motor	24	Heating ring
6	Sample arm	25	Coarse fiber
7	Detect probe	26	In water pump
8	Stir probe	27	out water pump
9	D.C.mator	28	Pump interface
10	Piston	29	Refrigeration fan
11	Glass tube	30	Filters
12	Circuit board	31	Platinum resistance
13	Switch Power Supply	32	Fan
14	Liquid level detection board	33	Diluter
15	Anticollision liquid level board	34	Circuit control board
16	Stir board	35	Valve
17	Cleanout head	36	Reagent bottle
18	Sample cup	37	Power cable
19	Reaction cup		

ISO 9001 & ISO 13485 Certified

Ver 1.0 Issue Date Jan. 2012

SINNOWA MEDICAL SCIENCE & TECHNOLOGY CO., LTD.

Add: Qilin Industrial Park Nanjing, China Z.P.: 211135
Tel: 86-025-84127188 – 8304 Fax: 86-25-84127199
<http://www.sinnowa.com> E-mail: info@sinnowa.com
